

**AUTOMATION
TECHNOLOGY**

**ISO AND VDMA
VALVES**

**STANDARD VALVES
FOR SPECIAL MARKETS
SIZES 01/1/2/3**

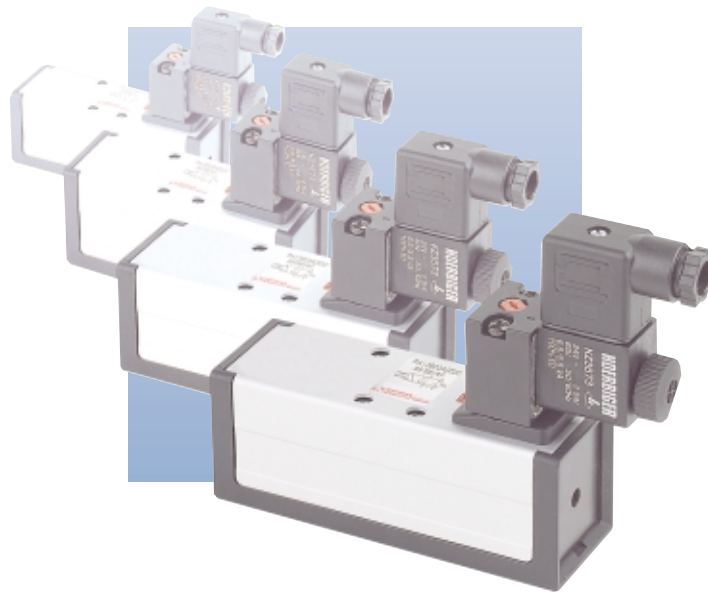

HOERBIGER
ORIGA

HOERBIGER-ORIGA ISO VALVES: LEADING TECHNOLOGY FOR MAXIMUM RELIABILITY AND PERFORMANCE

The heart of this valve, the spool, is constructed from a specialist ceramic material. Its unique design and material-properties guarantee absolute reliability and extremely long service life. The innovative technology is proven in wide spread markets and in the most demanding applications.

DESIGNED FOR HIGH-DEMAND MARKETS

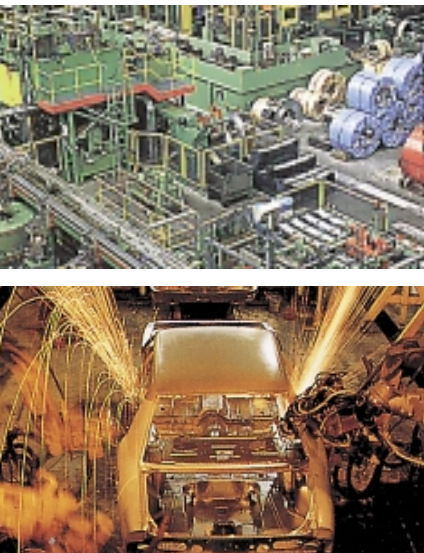

For many years ISO valves have been the recognized standard for the automotive industry and its suppliers. More recently, technological developments have resulted in the successful introduction and acceptance of the more compact VDMA standard valves and base plates.

QUALITY AND RELIABILITY – THE BASIS FOR TROUBLE-FREE SYSTEM OPERATION

- **High performance:**
Superior flow characteristics result from the highly efficient spool design and construction.
- **Constant performance:**
Low friction dynamic lip-seals ensure consistent operation for the complete valve life.
- **Compact construction:**
Valve dimensions do not exceed the standard base plate area.
- **Maintenance free:**
Suitable for use with dried and unlubricated or lubricated air, with no demand for routine maintenance.
- **Easy installation:**
Mounting screws are retained in valve body.

Cover plate can be exchanged for a pilot valve for electrical actuation.

Easy function selection between internal pilot or servo air supply, using a 2 position switch.

Manual override – tool operated for additional safety

Integrated valve gasket

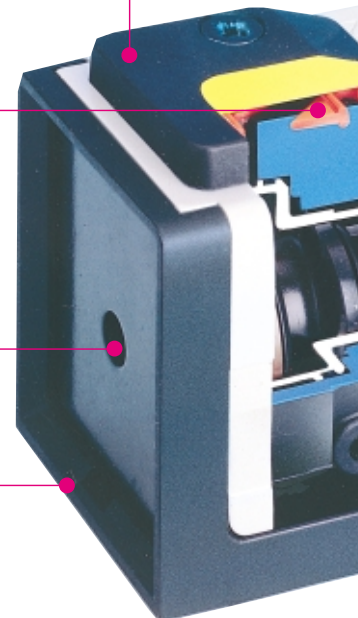

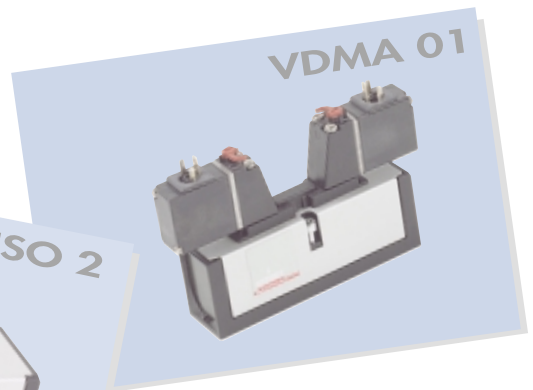
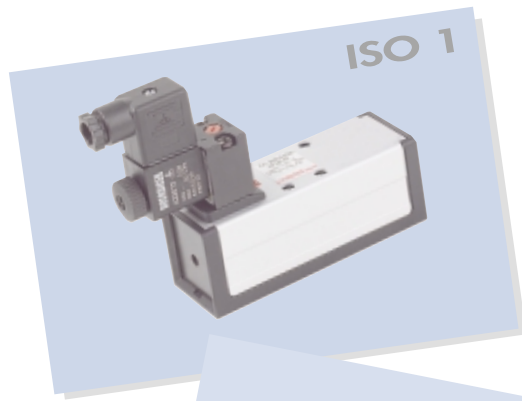

Retained mounting screws

Pressure amplifier integrated into the actuating piston, to minimize the actuation pressure.

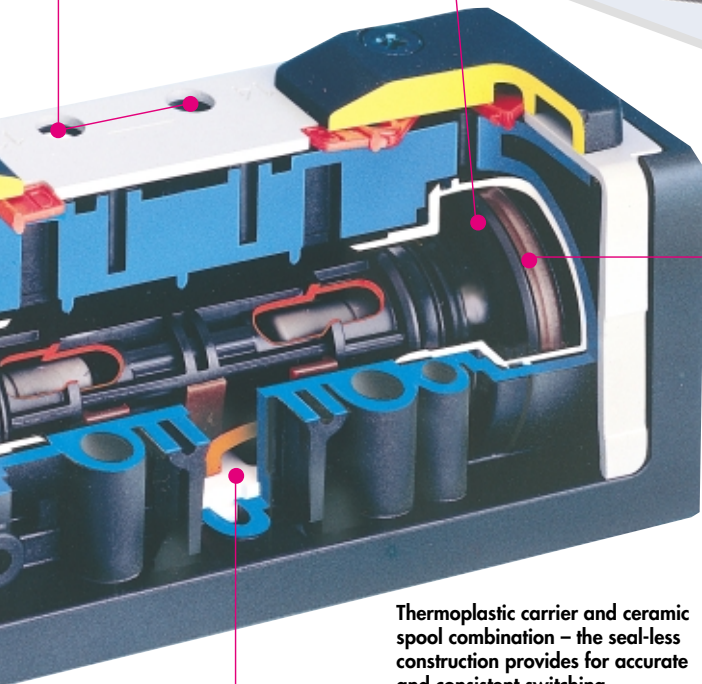

Low friction dynamic lip-seals ensure consistent operation for the complete valve life.

Thermoplastic carrier and ceramic spool combination – the seal-less construction provides for accurate and consistent switching, insensitive to air quality i.e. high reliability.



Ceramic spool for maximum service life. (25 million cycles, maintenance free with dried, unlubricated air).

- 5/2 and 5/3 way valves
- Pneumatically or electrically actuated
- All common voltages
- Pilot operated spring return
- Vacuum compatible

Single base plate, form A



VDMA

ISO

Base plates, form B



ISO

Modular bolt-together base plate, form C



VDMA

ISO

End plate set, form D for base plate combinations



VDMA

ISO

Angle base plate, form E

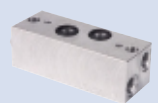

ISO

OVERVIEW – 5/2 STANDARD WAY VALVE

Actuation	Symbol	Order Instructions		Further Informations see Page
		Type	Order No.	
Pneumatic, by permanent signal, spring return		S20 561RF-01 (VDMA)	PA 12891	31,32
		S20 561RF-1	PA 12869	7,8
		S20 561RF-2	PA 16425	15,16
		S20 561RF-3	PA 16426	23,24
Pneumatic, by permanent signal, air spring return		S20 561R-01 (VDMA)	PA 12892	31,32
		S20 561R-1	PA 12870	7,8
		S20 561R-2	PA 16428	15,16
		S20 561R-3	PA 16429	23,24
Pneumatic, by impulse		S20 561-01 (VDMA)	PA 12893	31,32
		S20 561-1	PA 12868	7,8
		S20 561-2	PA 16422	15,16
Electrical, by permanent signal, spring return		S20 581RF-01-.. (VDMA)	PA 12886-..33	33-35
		S20 581RF-1-..	PA 12875-..33	9-11
		S20 581RF-2-..	PA 16441-..33	17-19
		S20 581RF-3-..	PA 16442-..33	25-27
with external pilot air		S20 581S-RF-01-.. (VDMA)	PA 12896-..33	33-35
		S20 581S-RF-1-..	PA 12882-..33	9-11
		S20 581S-RF-2-..	PA 16456-..33	17-19
		S20 581S-RF-3-..	PA 16462-..33	25-27
Electrical, by permanent signal, air spring return		S20 581R-01-.. (VDMA)	PA 12887-..33	33-35
		S20 581R-1-..	PA 12876-..33	9-11
		S20 581R-2-..	PA 16444-..33	17-19
		S20 581R-3-..	PA 16445-..33	25-27
Electrical, by impulse,		S20 581-01-.. (VDMA)	PA 12888-..33	33-35
		S20 581-1-..	PA 12874-..33	9-11
		S20 581-2-..	PA 16438-..33	17-19
		S20 581-3-..	PA 16439-..33	25-27
with external pilot air		S20 581S-01-.. (VDMA)	PA 12898-..33	33-35
		S20 581S-1-..	PA 12880-..33	9-11
		S20 581S-2-..	PA 16454-..33	17-19
		S20 581S-3-..	PA 16460-..33	25-27

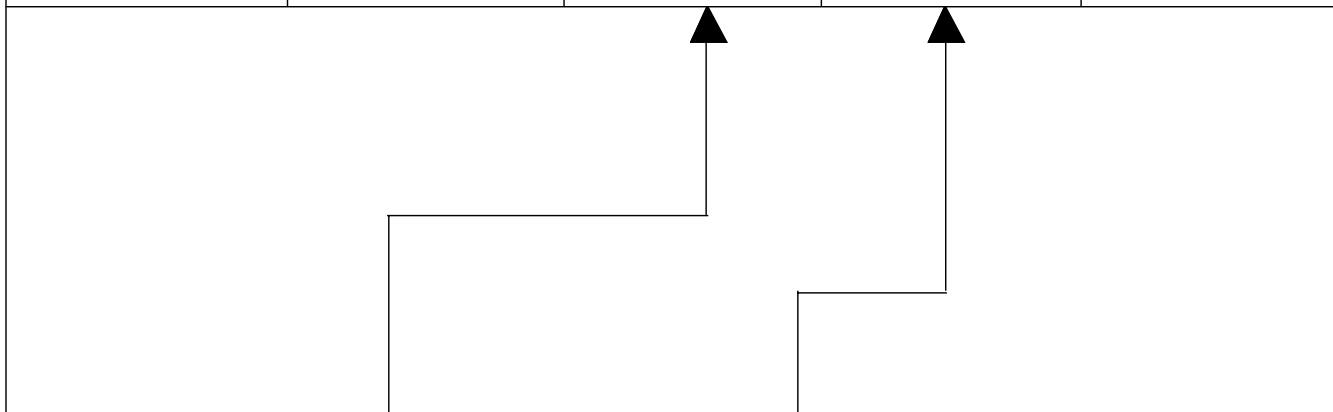

Solenoid version	Nominal voltage	Applicable for	Key code
Standard version	220 V/50 (60) Hz	110 V=	61
	24 V=	48 V/50 (60) Hz	02
Low wattage version	24 V=		13*
	220 V/50 (60) Hz		69*
Ex-proof version	24 V=		48*
	220 V/50 (60) Hz		98*

* only for ISO-Valves
Further voltages available on request.

OVERVIEW – 5/3 STANDARD WAY VALVE

Actuation	Symbol	Order Instructions		Further Informations see Page		
		Type	Order No.			
Pneumatic, by permanent signal, spring return to middle position		S20561RFG-01 (VDMA)	PA 12894	31,32		
		S20561RFG-1	PA 12871	7,8		
		S20561RFG-2	PA 16431	17-19		
		S20561RFG-3	PA 16432	23,24		
		S20561RFB-1	PA 12873	7,8		
		S20561RFB-2	PA 16437	23,24		
		S20561RFE-01 (VDMA)	PA 12895	33-35		
		S20561RFE-1	PA 12872	7,8		
		S20561RFE-2	PA 16434	17,19		
		S20561RFE-3	PA 16435	23,24		
	Electrical, by permanent signal, spring return to middle position		S20581RFG-01 (VDMA)	PA 12889-..33	33-35	
			S20581RFG-1-..	PA 12877-..33	9-11	
S20581RFG-2-..			PA 16447-..33	17-19		
S20581RFG-3-..			PA 16448-..33	25-27		
		S20581RFB-1-..	PA 12879-..33	9-11		
		S20581RFB-2-..	PA 16453-..33	17-19		
		S20581RFE-01 (VDMA)	PA 12890-..33	33-35		
		S20581RFE-1-..	PA 12878-..33	9-11		
		S20581RFE-2-..	PA 16450-..33	17-19		
		S20581RFE-3-..	PA 16451-..33	25-27		
		with external pilot air		S20581S-RFG-01.. (VDMA)	PA 12900-..33	33-35
				S20581S-RFG-1-..	PA 12883-..33	9-11
S20581S-RFG-2-..	PA 16457-..33			17-19		
	S20581S-RFB-1-..		PA 12885-..33	9-11		
	S20581S-RFB-2-..	PA 16459-..33	17-19			
	S20581S-RFE-01-.. (VDMA)	PA 12899..33	33-35			
	S20581S-RFE-1-..	PA 12884..33	9-11			
	S20581S-RFE-2-..	PA 16458..33	17-19			
	S20581S-RFE-3-..	PA 16464..33	25-27			
Solenoid version	Nominal voltage	Applicable for	Key code			
Standard version	220 V/50(60) Hz	110 V=	61			
	24 V=	48 V/50(60) Hz	02			
Low wattage version	24 V=		13*			
	220 V/50(60) Hz		69*			
Ex-proof version	24 V=		48*	* only for ISO-Valves Further voltages available on request.		
	220 V/50(60) Hz		98*			

OVERVIEW – 5/2 AND 5/3 WAY PIEZO VALVES

Actuation	Symbol	Order Instructions		Further Informations see Page	
		Type	Order No.		
Electrical, by permanent signal, spring return		S20 585RF-1-..	PS 13704-..1A	12-14	
		S20 585RF-2-..	PS 13724-..1A	20-22	
		S20 585RF-3-..	PS 13744-..1A	28-30	
with external pilot air		S20 585S-RF-1-..	PS 13705-..1A	12-14	
		S20 585S-RF-2-..	PS 13725-..1A	20-22	
		S20 585S-RF-3-..	PS 13745-..1A	28-30	
Electrical, by permanent signal, air spring return		S20 585R-1-..	PS 13702-..1A	12-14	
		S20 585R-2-..	PS 13722-..1A	20-22	
		S20 585R-3-..	PS 13742-..1A	28-30	
with external pilot air		S20 585S-R-1-..	PS 13703-..1A	12-14	
		S20 585S-R-2-..	PS 13723-..1A	20-22	
		S20 585S-R-3-..	PS 13743-..1A	28-30	
Electrical, by impulse,		S20 585-1-..	PS 13700-..1A	12-14	
		S20 585-2-..	PS 13720-..1A	20-22	
		S20 585-3-..	PS 13740-..1A	28-30	
	with external pilot air		S20 585S-1-..	PS 13701-..1A	12-14
			S20 585S-2-..	PS 13721-..1A	20-22
			S20 585S-3-..	PS 13741-..1A	28-30
Electrical, by permanent signal, spring return to middle position		S20 585RFG-1-..	PS 13706-..1A	12-14	
		S20 585RFG-2-..	PS 13726-..1A	20-22	
		S20 585RFG-3-..	PS 13746-..1A	28-30	
		S20 585RFB-1-..	PS 13710-..1A	12-14	
		S20 585RFB-2-..	PS 13730-..1A	20-22	
		S20 585RFE-1-..	PS 13708-..1A	12-14	
		S20 585RFE-2-..	PS 13728-..1A	20-22	
		S20 585RFE-3-..	PS 13748-..1A	28-30	
	with external pilot air		S20 585S-RFG-1-..	PS 13707-..1A	12-14
			S20 585S-RFG-2-..	PS 13727-..1A	20-22
			S20 585S-RFG-3-..	PS 13747-..1A	28-30
		S20 585S-RFB-1-..	PS 13711-..1A	12-14	
		S20 585S-RFB-2-..	PS 13731-..1A	20-22	
		S20 585S-RFE-1-..	PS 13709-..1A	12-14	
		S20 585S-RFE-2-..	PS 13729-..1A	20-22	
		S20 585S-RFE-3-..	PS 13749-..1A	28-30	

Piezo version	Nominal voltage	Type key	Key code	* Note: Because of the very small power consumption, residual and leakage currents of the controlling circuit can cause unintended switching of the valve, if they are larger than the operating current.
Standard version	24-250VDC 20-230V AC	A *	13	
	24VDC Ex	E	21	
	7,5VDC Ex	N	51	
Special version	24V DC	D	30	
	Pilot-Valve with NO-Function request			

Characteristics to VDI 3290

Pressures quoted as gauge pressure

Characteristics	Symbol	Unit	Description	
General Features				
Type			Ceramic Spool Valve	
Mounting			On base plate, to ISO 5599	
Tube connection			Base plate	
Port size			G1/4 (base plate)	
Weight (mass)		kg	0.32	
Installation			In any position	
Ambient temperature range	ϑ_{\min} ϑ_{\max}	°C °C	-10 +60	Note: When using below freezing point (°C) it is necessary to consult us.
Medium temperature range	ϑ_{\min} ϑ_{\max}	°C °C	-10 +60	
Medium			Filtered compressed air	
Lubrication			With or without oil mist lubrication ¹⁾	
Pneumatic Characteristics				
Nominal pressure	p_n	bar	6	
Operating pressure range	p_{\min} p_{\max}	bar bar	-0.9 12	
				5/2 way valve
Nominal flow	Q_N	l/min	1380	1380
Actuation				
Pneumatic			Direct	
Actuation pressure range	$p_{st \min}$ $p_{st \max}$	bar bar	2 12	

¹⁾ We recommended the use of mineral oil type VG32 to ISO 3448

5/2 and 5/3 Way Valves

to ISO 5599
Size 1

Actuation:
- pneumatic, permanent signal
- pneumatic, impulse

Series S20

S20 561RF-1
S20 561R-1
S20 561-1



S20 561RF.-1

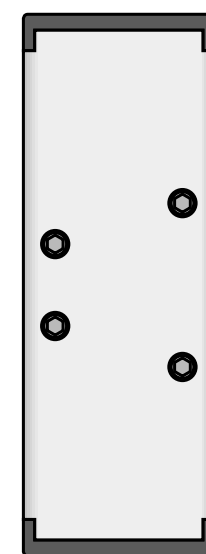
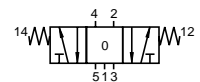

Comprises:
1 valve with
mounting
screws
1 gasket



For base plates see pages 36-41

Dimensions (mm)

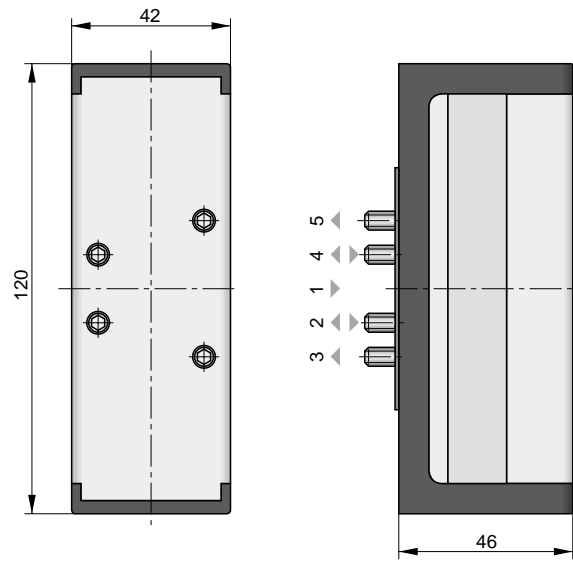

Order Instructions

Actuation	Return	Symbol	Order Instructions	
			Type	Order No.
Pneumatic, by permanent signal	Spring return		S20 561RF-1	PA 12869
Pneumatic, by permanent signal	Spring return (pilot operated)		S20 561R-1	PA 12870
Pneumatic, by impulse	Pneumatic, by impulse		S20 561-1	PA 12868
Pneumatic, by permanent signal spring return to middle position	Middle position closed		S20 561RFG-1	PA 12871
	Middle position pressurized		S20 561RFB-1	PA 12873
	Middle position exhausted		S20 561RFE-1	PA 12872

Characteristics to VDI 3290

Pressures quoted as gauge pressure

Characteristics	Symbol	Unit	Description		
General Features					
Type			Ceramic Spool Valve		
Mounting			On base plate, to ISO 5599		
Tube connection			Base plate		
Port size			G1/4 (base plate)		
Weight (mass)		kg	0,46 permanent signal 0,59 impulse		
Installation			In any position		
Ambient temperature range	ϑ_{\min} ϑ_{\max}	°C °C	-10 +60	Note: When using below freezing point (°C) it is necessary to consult us.	
Medium temperature range	ϑ_{\min} ϑ_{\max}	°C °C	-10 +60		
Medium			Filtered compressed air		
Lubrication			With or without oil mist lubrication ¹⁾		
Pneumatic Characteristics					
Nominal pressure	p_n	bar	6		
Operating pressure range	p_{\min}	bar	2		
			-1 (Version S)		
	p_{\max}	bar	12		
Nominal flow	Q_N	l/min	5/2 way valve	5/3 way valve	
			1380	1380	
Actuation					
Electrical			Pilot operated, Pilot operated with external pilot air		
Actuation pressure range	$p_{st \min}$	bar	2		
	$p_{st \max}$	bar	10		
Voltage type			AC	DC	
Nominal voltage*	Standard version	U_n	V	220	24
	Low watt. version	U_n	V	220	24
	Ex-proof version	U_n	V	220	24
			Further voltages available on request		
Initial power consumption	Standard version		VA (W)	11	4.8
	Low watt. version		VA (W)	7.8	2.7
	Ex-proof version		VA (W)	5	5.1
Continuous consumption	Standard version		VA (W)	8.5	4.8
	Low watt. version		VA (W)	4.9	2.7
	Ex-proof version		VA (W)	5	5.1
Duty cycle	ED	%	100		
Electrical protection			IP65 to DIN 40050 (with plug)		
Insulating material			F (Ex-version E) to VDE 0580		
Connection			Plug to DIN 43650 form B - Industry norm ²⁾ Ex-version: cable 1.200 mm long		

* See Order Instructions for details

¹⁾ We recommended the use of mineral oil type VG32 to ISO 3448

²⁾ Plug for low watt applications available in DIN 43650 form A

5/2 and 5/3 Way Valves

to ISO 5599
Size 1

Actuation:
Electrical pilot operated
with standard solenoids
- by permanent signal
- by impulse

Series S20

S20581 RF-1..

S20581 R-1..

S20581-1..

S20581S-1..

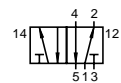

S20581 RF.-1..

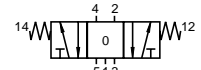

S20581 S-RF.-1..

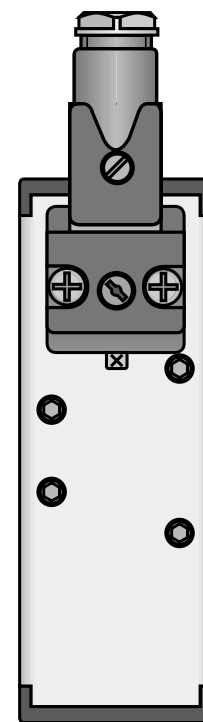
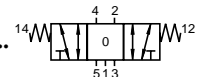

Comprises:
1 valve with
mounting
screws
1 gasket

HOERBIGER

ORIGA

For baseplates see pages 36-41

Dimensions (mm)

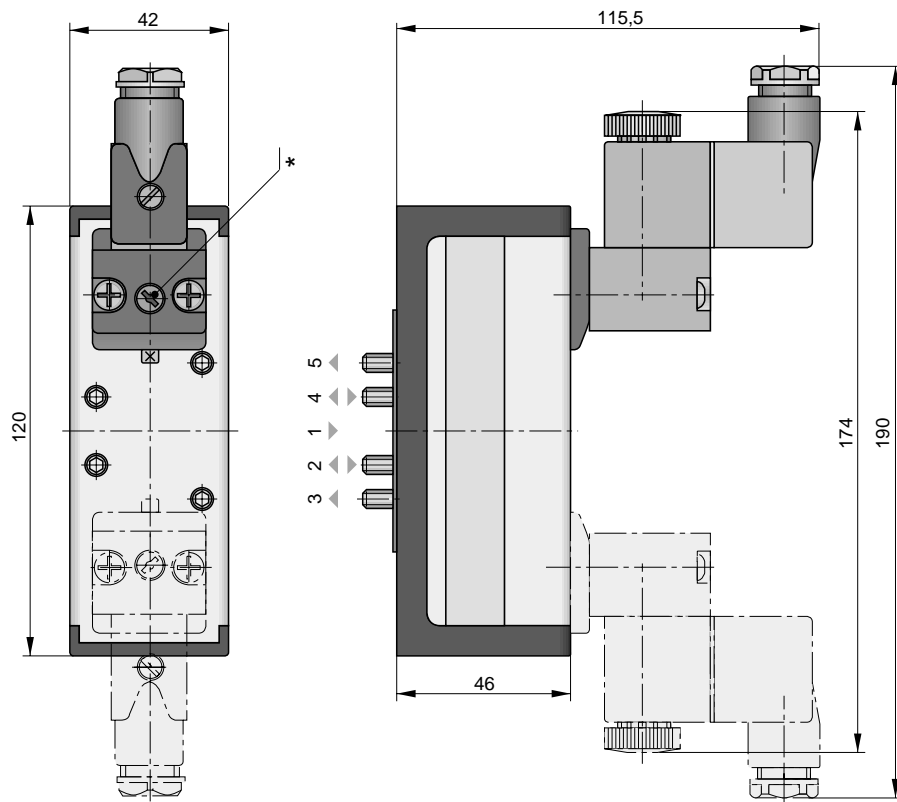

* Manual actuation

Dimensions (mm)
Low wattage solenoid

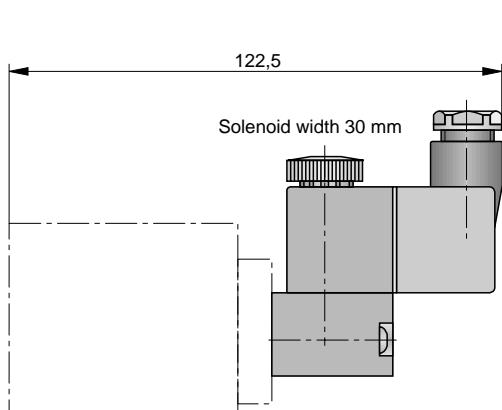

Dimensions (mm)
Ex-proof solenoid

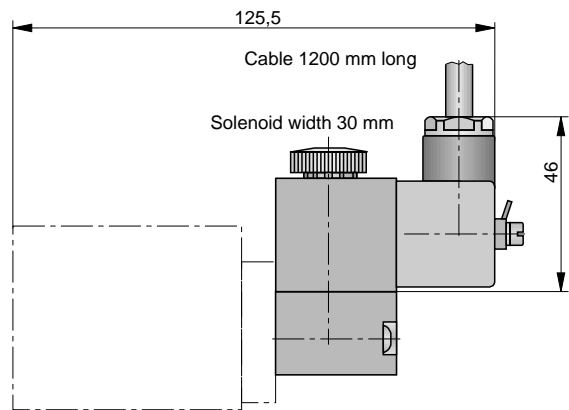

Order Instructions

Actuation	Return	Symbol	Type	Order Instructions Order No.
Electrical, by permanent signal	Spring return		S20 581RF-1-..	PA 12875-..33
	with external pilot air		S20 581S-RF-1-..	PA 12882-..33
Electrical, by permanent signal	Spring return (pilot operated)		S20 581R-1-..	PA 12876-..33
Electrical, by impulse	Electrical, by impulse		S20 581-1-..	PA 12874-..33
	with external pilot air	with external pilot air		S20 581S-1-..
Electrical, by permanent signal spring return to middle position	Middle position closed		S20 581RFG-1-..	PA 12877-..33
	Middle position pressurized		S20 581RFB-1-..	PA 12879-..33
	Middle position exhausted		S20 581RFE-1-..	PA 12878-..33
with external pilot air	Middle position closed		S20 581S-RFG-1-..	PA 12883-..33
	Middle position pressurized		S20 581S-RFB-1-..	PA 12885-..33
	Middle position exhausted		S20 581S-RFE-1-..	PA 12884-..33

Solenoid version	Nominal voltage	Applicable for	Key code
Standard version	220 V/50 (60) Hz	110V=	61
	24 V=	48 V/50 (60) Hz	02
Low wattage version	24 V=		13
	220V/50 (60) Hz		69
Ex-proof version	24 V=		48
	220V/50 (60) Hz		98

Further voltages available on request.

5/2 and 5/3 Way Valves

to ISO 5599
Size 1

Actuation:
electrically piloted
with piezo valve
- by permanent signal
- by impulse

Series S20

S20 585-1..

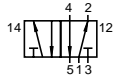

S20 585 RF.-1..

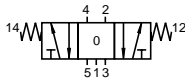

S20 585 S-RF.-1..

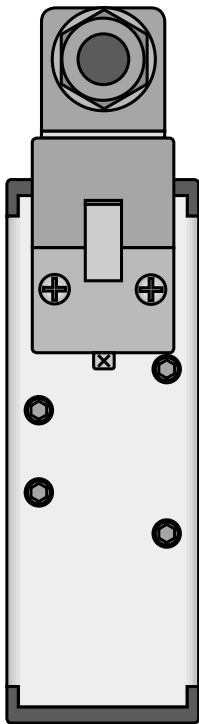
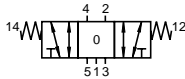

Comprises:
1 Valve with
mounting screws
1 gasket

Characteristics to VDI 3290

Pressures quoted as gauge pressures

Characteristic	Symbol	Unit	Description		
General Features					
Type			Ceramic Spool Valve		
Mounting			On base plate to ISO 5599		
Tube connection			Base plate		
Port size			G1/4 (base plate)		
Weight (mass)		kg	0.46 permanent signal 0.59 impulse		
Installation			In any position		
Ambient temperature range	ϑ_{\min} ϑ_{\max}	°C °C	-10 +60	Note: When using below freezing	
Medium temperature range	ϑ_{\min} ϑ_{\max}	°C °C	-10 +60	point (°C) it is necessary to consult us.	
Medium			filtered air		
Lubrication			with or without oil mist lubrication ¹⁾		
Pneumatic Characteristics					
Nominal Pressure	p_n	bar	6		
Operating pressure range	p_{\min}	bar	2		
			-1 (version S)		
	p_{\max}	bar	12		
Nominal flow	Q_N	l/min	5/2 way valve	5/3 way valve	
			1380	1380	
Actuation					
Electrical			Pilot operated Pilot operated, with external pilot air		
Voltage			Universal voltage	Ex-proof	Ex-proof low voltage
Nominal voltage*	U_N	V	24-250 DC 20-230 AC	24 DC	7.5 DC ± 10%
Nominal power	P_N	W	0.003 (24 V DC) 0.77 (220 V AC)	0.006	0.015
Initial current		mA	10-14	1.6	-
Continuous current		mA	0.1 (24 V DC) 3.5 (220 V AC)	0.24	2
Switching voltage	U_{on}	V	> 21.5	> 21.5	> 6
	U_{max}	V	250 DC 230 AC	30	15.5
	U_{out}	V	< 12	< 5	< 2
Duty cycle	ED	%	100 ²⁾	100 ²⁾	100 ²⁾
Electrical protection			IP54	EEx ib IIC T6	EEx ia IIC T6/T5
Connection			Plug to DIN 43650A		

* See Order Instructions for details

¹⁾ We recommend the use of mineral oil type VG32 to ISO 3448

²⁾ not suited as safety valve with 100% ED

Dimensions (mm)

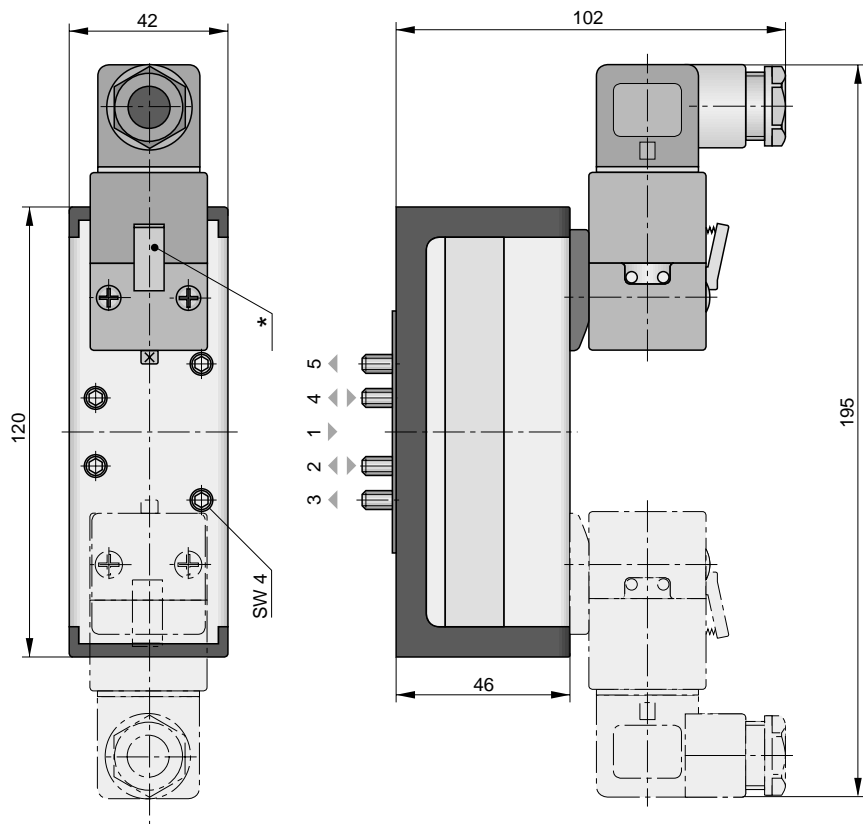

* Manual actuation

Order Instructions

Actuation	Return	Symbol	Order Instructions	
			Type	Order No.
Electrical, by permanent signal	Spring return		S20585RF-1-..	PS 13704-..1A
	with external pilot air		S20585S-RF-1-..	PS 13705-..1A
Electrical, by permanent signal	Spring return (pilot operated)		S20585R-1-..	PS 13702-..1A
	with external pilot air		S20585S-R-1-..	PS 13703-..1A
Electrical, by impulse	Electrical, by impulse		S20585-1-..	PS 13700-..1A
	with external pilot air		S20585S-1-..	PS 13701-..1A
Electrical, by permanent signal spring return to middle position	Middle position closed		S20585RFG-1-..	PS 13706-..1A
	Middle position pressurized		S20585RFB-1-..	PS 13710-..1A
	Middle position exhausted		S20585RFE-1-..	PS 13708-..1A
with external pilot air	Middle position closed		S20585S-RFG-1-..	PS 13707-..1A
	Middle position pressurized		S20585S-RFB-1-..	PS 13711-..1A
	Middle position exhausted		S20585S-RFE-1-..	PS 13709-..1A

Piezo Version	Nominal voltage	Type key	Key code	* Note: Because of the very small power consumption, residual and leakage currents of the controlling circuit can cause unintended switching of the valve, if they are larger than the operating current.
Standard version	24-250VDC 20-230V AC	A *	13	
	24VDC Ex	E	21	
	7,5VDC Ex	N	51	
Special version	24V DC	D	30	
	Pilot-Valve with NO-Function on request			

Characteristics to VDI 3290

Pressures quoted as gauge pressure

Characteristics	Symbol	Unit	Description	
General Features				
Type			Ceramic Spool Valve	
Mounting			On base plate, to ISO 5599	
Tube connection			Base plate	
Port size			G3/8 (base plate)	
Weight (mass)		kg	0.56	
Installation			In any position	
Ambient temperature range	ϑ_{\min} ϑ_{\max}	°C °C	-10 +60	Note: When using below freezing point (°C) it is necessary to consult us.
Medium temperature range	ϑ_{\min} ϑ_{\max}	°C °C	-10 +60	
Medium			Filtered compressed air	
Lubrication			With or without oil mist lubrication ¹⁾	
Pneumatic Characteristics				
Nominal pressure	p_n	bar	6	
Operating pressure range	p_{\min} p_{\max}	bar bar	-0.9 12	
				5/2 way valve
Nominal flow	Q_N	l/min	3720	3720
Actuation				
Pneumatic			Direct	
Actuation pressure range	$p_{st\ min}$	bar	2	
	$p_{st\ max}$	bar	12	

¹⁾ We recommended the use of mineral oil type VG32 to ISO 3448

5/2 and 5/3 Way Valves

to ISO 5599
Size 2

Actuation:
- pneumatic, permanent signal
- pneumatic, impulse

Series S20

S20 561RF-2
S20 561R-2
S20 561-2



S20 561RF.-2

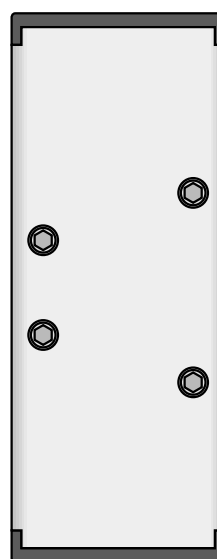
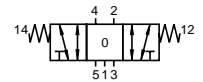

Comprises:
1 valve with
mounting
screws
1 gasket

HOERBIGER
ORIGA

For base plates see pages 36-41

Dimensions (mm)

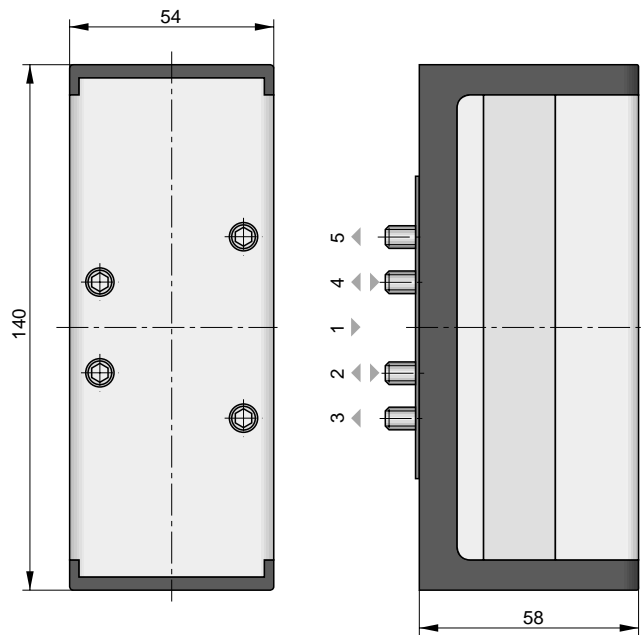

Order Instructions

Actuation	Return	Symbol	Order Instructions	
			Type	Order No.
Pneumatic, by permanent signal	Spring return		S20 561RF-2	PA 16425
Pneumatic, by permanent signal	Spring return (pilot operated)		S20 561R-2	PA 16428
Pneumatic, by impulse	Pneumatic, by impulse		S20 561-2	PA 16422
Pneumatic, by permanent signal spring return to middle position	Middle position closed		S20 561RFG-2	PA 16431
	Middle position pressurized		S20 561RFB-2	PA 16437
	Middle position exhausted		S20 561RFE-2	PA 16434

Characteristics to VDI 3290

Pressures quoted as gauge pressure

Characteristics	Symbol	Unit	Description		
General Features					
Type			Ceramic Spool Valve		
Mounting			On base plate, to ISO 5599		
Tube connection			Base plate		
Port size			G3/8 (base plate)		
Weight (mass)		kg	0,70 permanent signal 0,83 impulse		
Installation			In any position		
Ambient temperature range	ϑ_{\min} ϑ_{\max}	°C °C	-10 +60	Note: When using below freezing point (°C) it is necessary to consult us.	
Medium temperature range	ϑ_{\min} ϑ_{\max}	°C °C	-10 +60		
Medium			Filtered compressed air		
Lubrication			With or without oil mist lubrication ¹⁾		
Pneumatic Characteristics					
Nominal pressure	p_n	bar	6		
Operating pressure range	p_{\min}	bar	2		
			-1 (Version S)		
	p_{\max}	bar	12		
Nominal flow	Q_N	l/min	5/2 way valve	5/3 way valve	
			3720	3720	
Actuation					
Electrical			Pilot operated, Pilot operated with external pilot air		
Actuation pressure range	$p_{st \min}$	bar	2		
	$p_{st \max}$	bar	12		
Voltage type			AC	DC	
Nominal voltage *	Standard version	U_n	V	220	24
	Low watt. version	U_n	V	220	24
	Ex-proof version	U_n	V	220	24
Further voltages available on request					
Initial power consumption	Standard version		VA (W)	11	4.8
	Low watt. version		VA (W)	7.8	2.7
	Ex-proof version		VA (W)	5	5.1
Continuous consumption	Standard version		VA (W)	8.5	4.8
	Low watt. version		VA (W)	4.9	2.7
	Ex-proof version		VA (W)	5	5.1
Duty cycle	ED	%	100		
Electrical protection			IP65 to DIN 40050 (with plug)		
Insulating material			F (Ex-version E) to VDE 0580		
Connection			Plug to DIN 43650 form B - Industry norm ²⁾ Ex-version: cable 1.200 mm long		

* See Order Instructions for details

¹⁾ We recommended the use of mineral oil type VG32 to ISO 3448

²⁾ Plug for low watt applications available in DIN 43650 form A

5/2 and 5/3 Way Valves

to ISO 5599
Size 2

Actuation:
Electrical pilot operated
with standard solenoids
- by permanent signal
- by impulse

Series S20

S20581RF-2..
S20581R-2..
S20581-2..
S20581S-2..

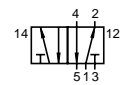

S20581 RF.-2..

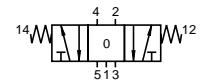

S20581 S-RF.-2..

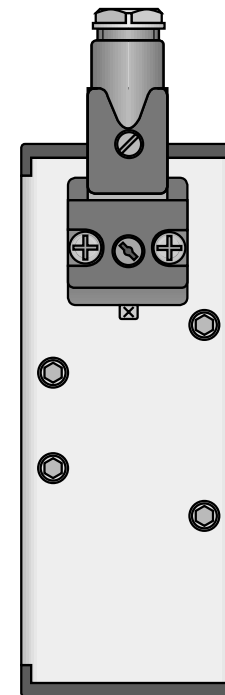
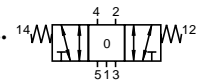

Comprises:
1 valve with
mounting
screws
1 gasket

HOERBIGER

ORIGA

For base plates see pages 36-41

Dimensions (mm)

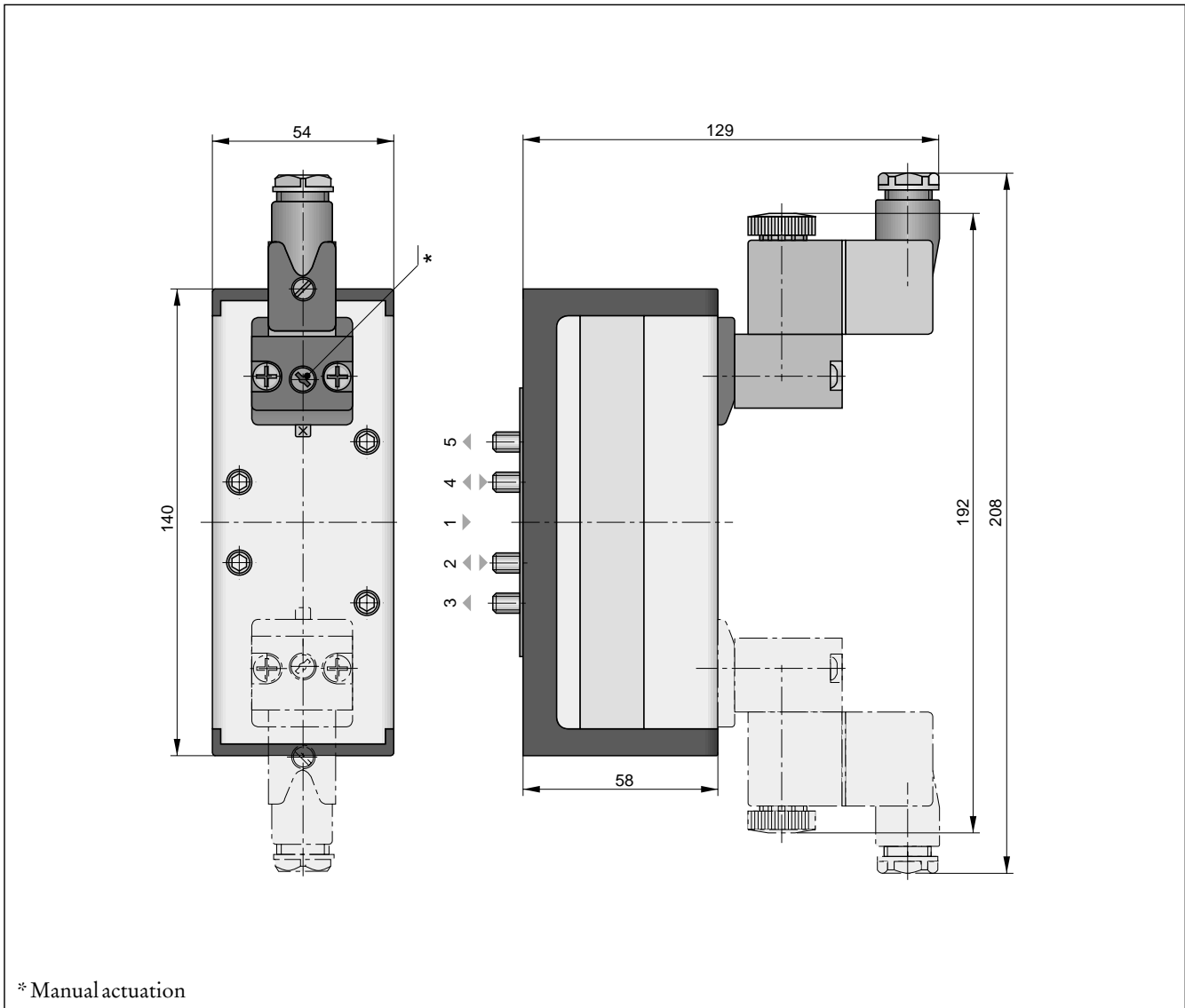

**Dimensions (mm)
Low wattage solenoid**

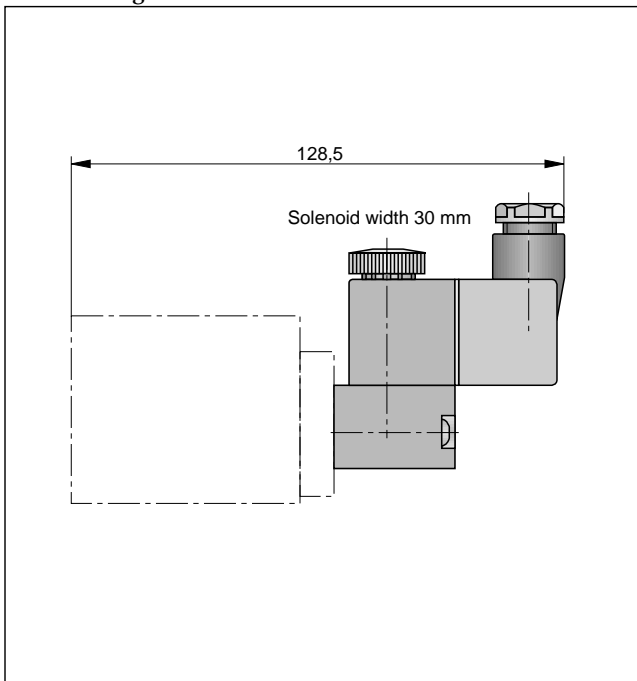

**Dimensions (mm)
Ex-proof solenoid**

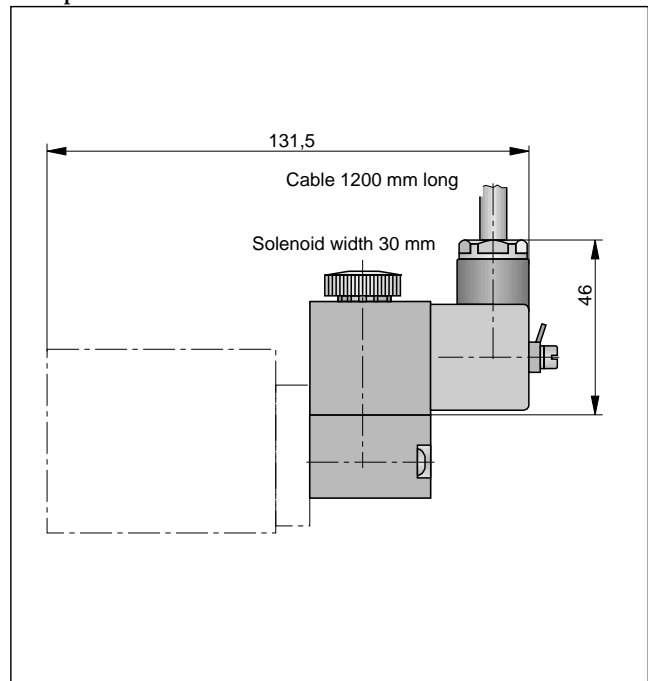

Order Instructions

Actuation		Return	Symbol	Type	Order Instructions	Order No.
Electrical, by permanent signal	Spring return			S20 581RF-2-..		PA 16441-...33
	with external pilot air	Spring return		S20 581S-RF-2-..		PA 16456-...33
Electrical, by permanent signal	Spring return (pilot operated)			S20 581R-2-..		PA 16444-...33
Electrical, by impulse	Electrical, by impulse			S20 581-2-..		PA 16438-...33
	with external pilot air	with external pilot air		S20 581S-2-..		PA 16454-...33
Electrical, by permanent signal spring return to middle position	Middle position closed			S20 581RFG-2-..		PA 16447-...33
	Middle position pressurized			S20 581RFB-2-..		PA 16453-...33
	Middle position exhausted			S20 581RFE-2-..		PA 16450-...33
with external pilot air	Middle position closed			S20 581S-RFG-2-..		PA 16457-...33
	Middle position pressurized			S20 581S-RFB-2-..		PA 16459-...33
	Middle position exhausted			S20 581S-RFE-2-..		PA 16458-...33
Solenoid version	Nominal voltage	Applicable for	Key code			
Standard version	220 V/50 (60) Hz	110V=	61			
	24 V=	48 V/50 (60) Hz	02			
Low wattage version	24 V=		13			
	220V/50 (60) Hz		69			
Ex-proof version	24 V=		48			
	220V/50 (60) Hz		98	Further voltages available on request.		

5/2 and 5/3 Way Valves

to ISO 5599
Size 2

Actuation:
electrically piloted
with piezo valve
- by permanent signal
- by impulse

Series S20

S20 585-2..

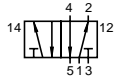

S20 585 RF.-2..

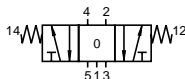

S20 585 S-RF.-2..

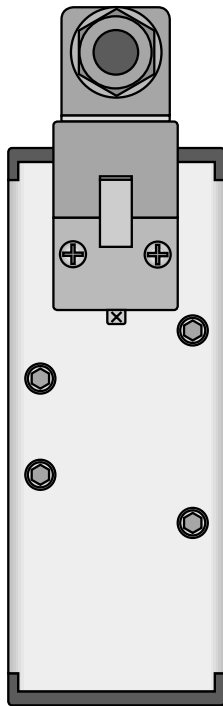
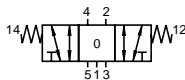

Comprises:
1 Valve with
mounting
screws
1 gasket

Characteristics to VDI 3290

Pressures quoted as gauge pressures

Characteristic	Symbol	Unit	Description		
General Features					
Type			Ceramic Spool Valve		
Mounting			On base plate to ISO 5599		
Tube connection			Base plate		
Port size			G3/8 (base plate)		
Weight (mass)		kg	0.70 permanent signal 0.83 impulse		
Installation			In any position		
Ambient temperature range	ϑ_{\min} ϑ_{\max}	°C °C	-10 +60	Note: When using below freezing	
Medium temperature range	ϑ_{\min} ϑ_{\max}	°C °C	-10 +60	point (°C) it is necessary to consult us.	
Medium			filtered air		
Lubrication			with or without oil mist lubrication ¹⁾		
Pneumatic Characteristics					
Nominal Pressure	p_n	bar	6		
Operating pressure range	p_{\min}	bar	2		
			-1 (version S)		
	p_{\max}	bar	12		
Nominal flow	Q_N	l/min	5/2 way valve	5/3 way valve	
			3720	3720	
Actuation					
Electrical			Pilot operated Pilot operated, with external pilot air		
Voltage			Universal voltage	Ex-proof	Ex-proof low voltage
Nominal voltage*	U_N	V	24-250 DC 20-230 AC	24 DC	7.5 DC ± 10%
Nominal power	P_N	W	0.003 (24 VDC) 0.77 (220 V AC)	0.006	0.015
Initial current		mA	10-14	1.6	-
Continuous current		mA	0.1 (24 VDC) 3.5 (220 V AC)	0.24	2
Switching voltage	U_{on}	V	> 21.5	> 21.5	> 6
	U_{max}	V	250 DC 230 AC	30	15.5
	U_{out}	V	< 12	< 5	< 2
Duty cycle	ED	%	100 ²⁾	100 ²⁾	100 ²⁾
Electrical protection			IP 54	EEx ib IIC T6	EEx ia IIC T6/T5
Connection			Plug to DIN 43650A		

* See Order Instructions for details

¹⁾ We recommend the use of mineral oil type VG32 to ISO 3448

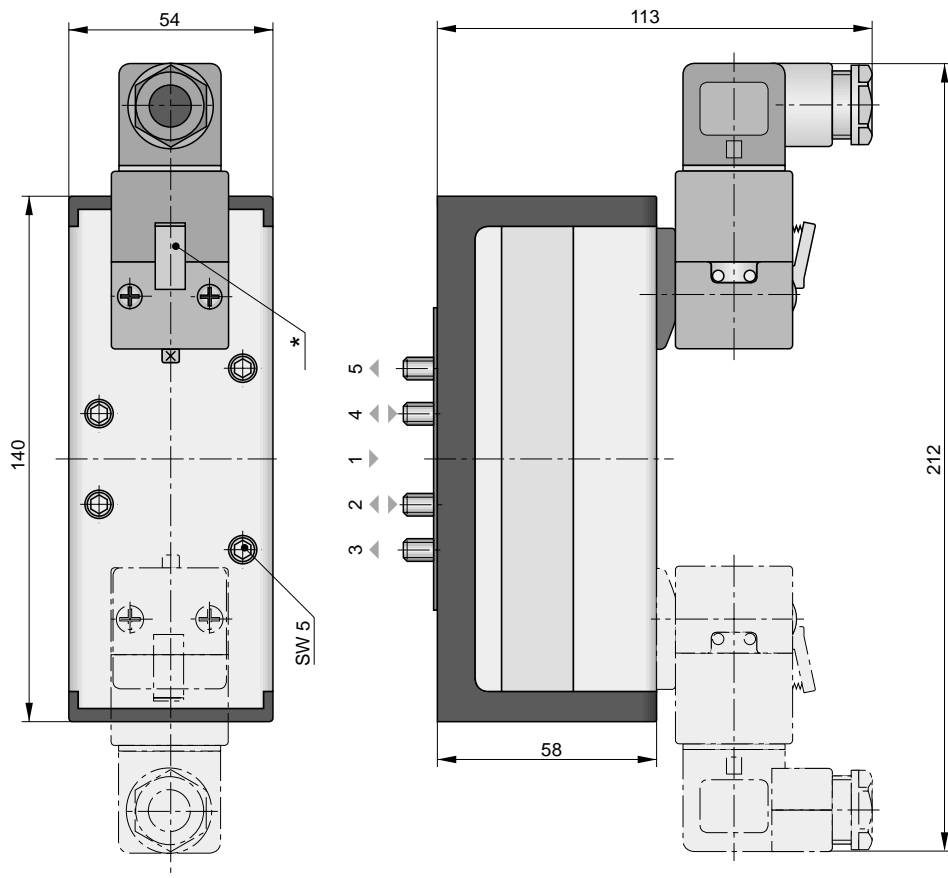

²⁾ not suited as safety valve with 100% ED

Dimensions (mm)

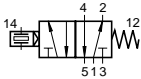
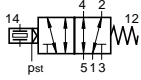
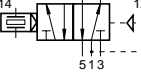
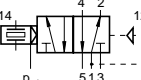
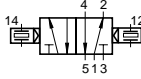
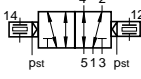
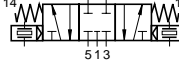
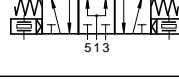
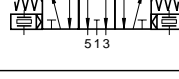

* Manual actuation

Order Instructions

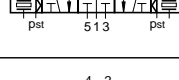
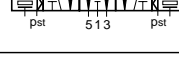
Actuation	Return	Symbol	Order Instructions	
			Type	Order No.
Electrical, by permanent signal	Spring return		S20 585RF-2-..	PS 13724-..1A
	with external pilot air	Spring return		S20 585S-RF-2-..
Electrical, by permanent signal	Spring return (pilot operated)		S20 585R-2-..	PS 13722-..1A
	with external pilot air	Spring return (pilot operated)		S20 585S-R-2-..
Electrical, by impulse	Electrical, by impulse		S20 585-2-..	PS 13720-..1A
	with external pilot air	with external pilot air		S20 585S-2-..
Electrical, by permanent signal spring return to middle position	Middle position closed		S20 585RFG-2-..	PS 13726-..1A
	Middle position pressurized		S20 585RFB-2-..	PS 13730-..1A
	Middle position exhausted		S20 585RFE-2-..	PS 13728-..1A
with external pilot air	Middle position closed		S20 585S-RFG-2-..	PS 13727-..1A
	Middle position pressurized		S20 585S-RFB-2-..	PS 13731-..1A
	Middle position exhausted		S20 585S-RFE-2-..	PS 13729-..1A

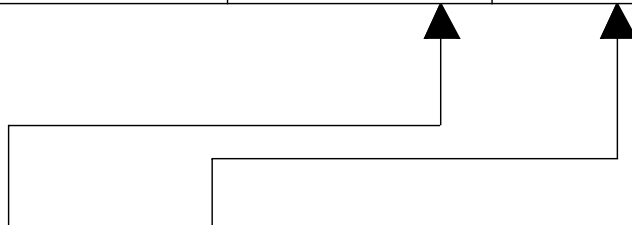

Piezo Version	Nominal voltage	Type key	Key code
Standard version	24-250V DC 20-230V AC	A *	13
	24VDC Ex	E	21
	7,5VDC Ex	N	51
Special version	24V DC	D	30
	Pilot-Valve with NO-function on request		

* Note:
Because of the very small power consumption, residual and leakage currents of the controlling circuit can cause unintended switching of the valve, if they are larger than the operating current.

Characteristics to VDI 3290

Pressures quoted as gauge pressure

Characteristics	Symbol	Unit	Description	
General Features				
Type			Ceramic Spool Valve	
Mounting			On base plate, to ISO 5599	
Tube connection			Base plate	
Port size			G1/2 (base plate)	
Weight (mass)		kg	1.1	
Installation			In any position	
Ambient temperature range	ϑ_{\min} ϑ_{\max}	°C °C	-10 +60	Note: When using below freezing point (°C) it is necessary to consult us.
Medium temperature range	ϑ_{\min} ϑ_{\max}	°C °C	-10 +60	
Medium			Filtered compressed air	
Lubrication			With or without oil mist lubrication ¹⁾	
Pneumatic Characteristics				
Nominal pressure	p_n	bar	6	
Operating pressure range	p_{\min} p_{\max}	bar bar	-0.9	5/2 way valve
			12	
Nominal flow	Q_N	l/min	6660	6660
Actuation				
Pneumatic			Direct	
Actuation pressure range	$p_{st \min}$ $p_{st \max}$	bar bar	2	
			12	

¹⁾ We recommended the use of mineral oil type VG32 to ISO 3448

5/2 and 5/3 Way Valves

to ISO 5599
Size 3

Actuation:
- pneumatic, permanent signal
- pneumatic, impulse

Series S20

S20 561RF-3
S20 561R-3
S20 561-3



S20 561RF.-3

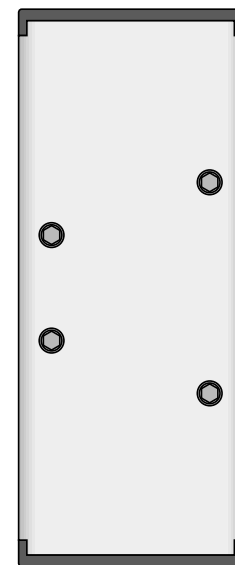
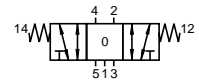

Comprises:
1 valve with
mounting
screws
1 gasket



For base plates see pages 36-41

Dimensions (mm)

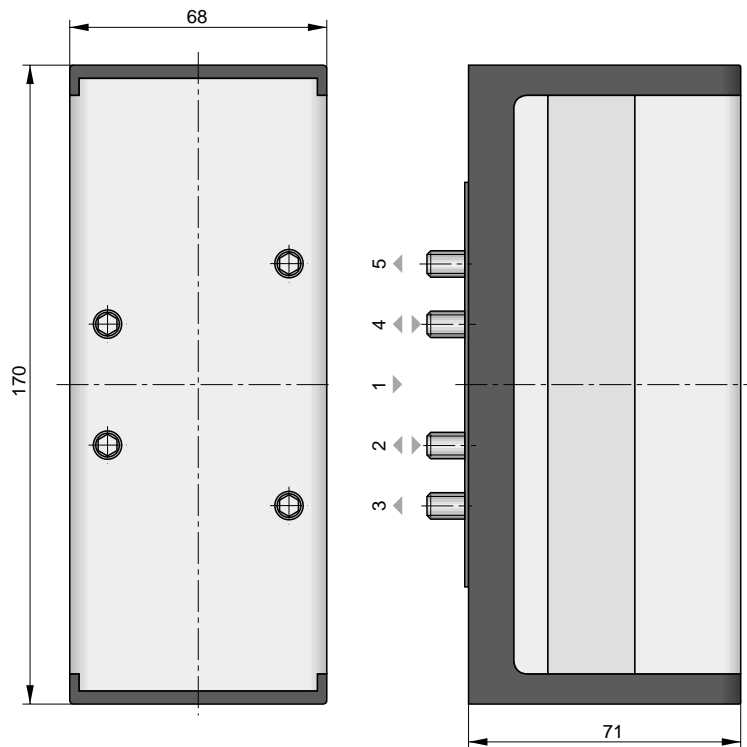

Order Instructions

Actuation	Return	Symbol	Type	Order Instructions Order No.
Pneumatic, by permanent signal	Spring return		S20 561RF-3	PA 16426
Pneumatic, by permanent signal	Spring return (pilot operated)		S20 561R-3	PA 16429
Pneumatic, by impulse	Pneumatic, by impulse		S20 561-3	PA 16423
Pneumatic, by permanent signal spring return to middle position	Middle position closed		S20 561RFG-3	PA 16432
	Middle position exhausted		S20 561RFE-3	PA 16435

Characteristics to VDI 3290

Pressures quoted as gauge pressure

Characteristics	Symbol	Unit	Description		
General Features					
Type			Ceramic Spool Valve		
Mounting			On base plate, to ISO 5599		
Tube connection			Base plate		
Port size			G1/2 (base plate)		
Weight (mass)		kg	1.23 permanent signal 1.37 impulse		
Installation			In any position		
Ambient temperature range	ϑ_{\min} ϑ_{\max}	°C °C	-10 +60	Note: When using below freezing point (°C) it is necessary to consult us.	
Medium temperature range	ϑ_{\min} ϑ_{\max}	°C °C	-10 +60		
Medium			Filtered compressed air		
Lubrication			With or without oil mist lubrication ¹⁾		
Pneumatic Characteristics					
Nominal pressure	p_n	bar	6		
Operating pressure range	p_{\min}	bar	2		
			-1 (Version S)		
	p_{\max}	bar	12		
Nominal flow	Q_N	l/min	5/2 way valve	5/3 way valve	
			6660	6660	
Actuation					
Electrical			Pilot operated, Pilot operated with external pilot air		
Actuation pressure range	$p_{st \min}$	bar	2		
	$p_{st \max}$	bar	10		
Voltage type			AC	DC	
Nominal voltage*	Standard version	U_n	V	220	24
	Low watt. version	U_n	V	220	24
	Ex-proof version	U_n	V	220	24
			Further voltages available on request		
Initial power consumption	Standard version		VA (W)	11	4.8
	Low watt. version		VA (W)	7.8	2.7
	Ex-proof version		VA (W)	5	5.1
Continuous consumption	Standard version		VA (W)	8.5	4.8
	Low watt. version		VA (W)	4.9	2.7
	Ex-proof version		VA (W)	5	5.1
Duty cycle	ED	%	100		
Electrical protection			IP65 to DIN 40050 (with plug)		
Insulating material			F (Ex-version E) to VDE 0580		
Connection			Plug to DIN 43650 form B - Industry norm ²⁾ Ex-version: cable 1.200 mm long		

* See Order Instructions for details

¹⁾ We recommended the use of mineral oil type VG32 to ISO 3448

²⁾ Plug for low watt applications available in DIN 43650 form A

5/2 and 5/3 Way Valves

 to ISO 5599
Size 3

Actuation:
 Electrical pilot operated
 with standard solenoids
 - by permanent signal
 - by impulse

Series S20

S20581RF-3..

S20581R-3..

S20581-3..

S20581S-3..

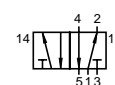

S20581 RF.-3..

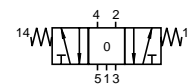

S20581 S-RF.-3..

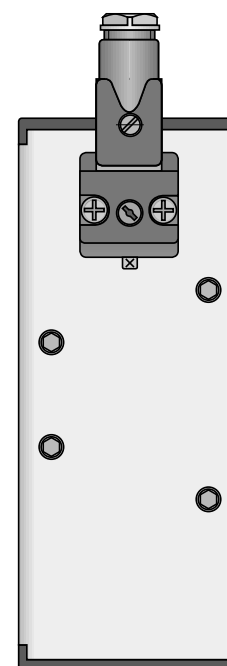
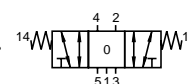

Comprises:
 1 valve with
 mounting
 screws
 1 gasket

HOERBIGER

ORIGA

For base plates see pages 36-41

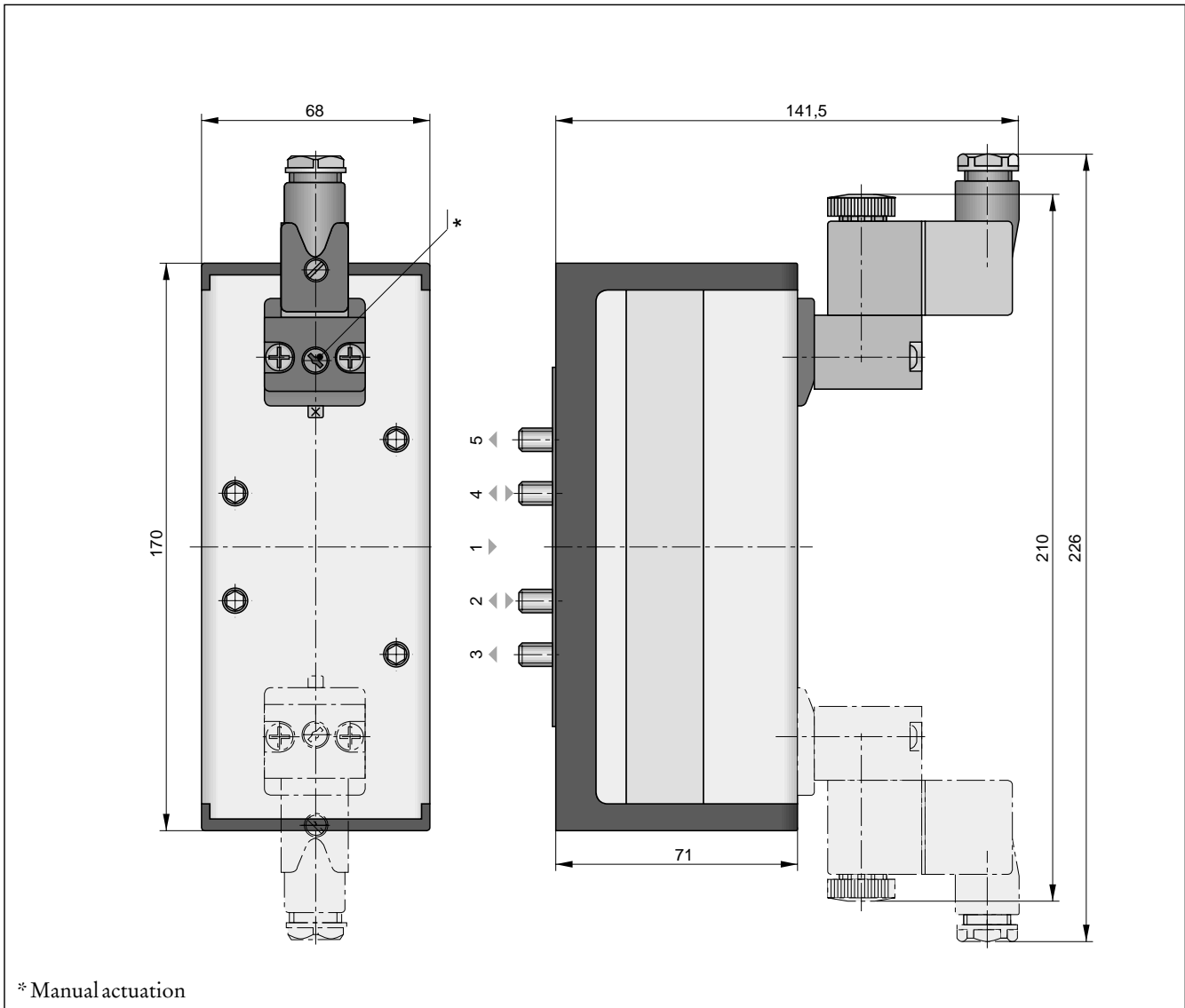
Dimensions (mm)



Dimensions (mm)
Low wattage solenoid

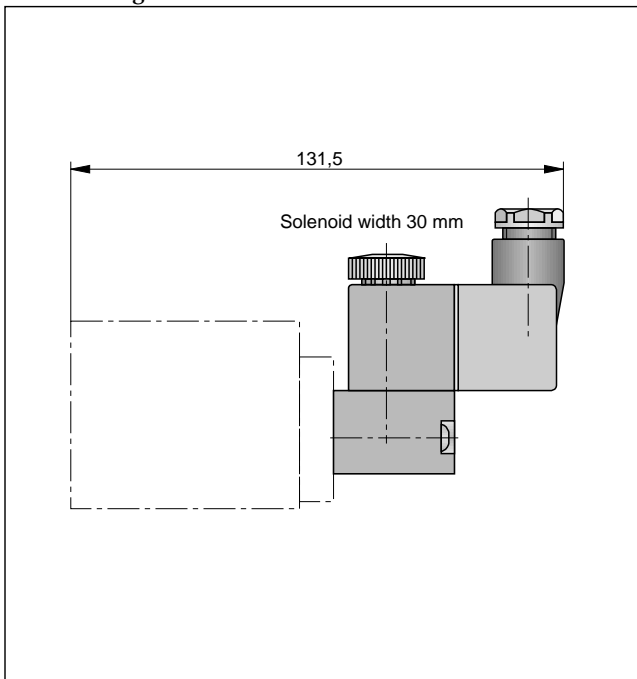

Dimensions (mm)
Ex-proof solenoid

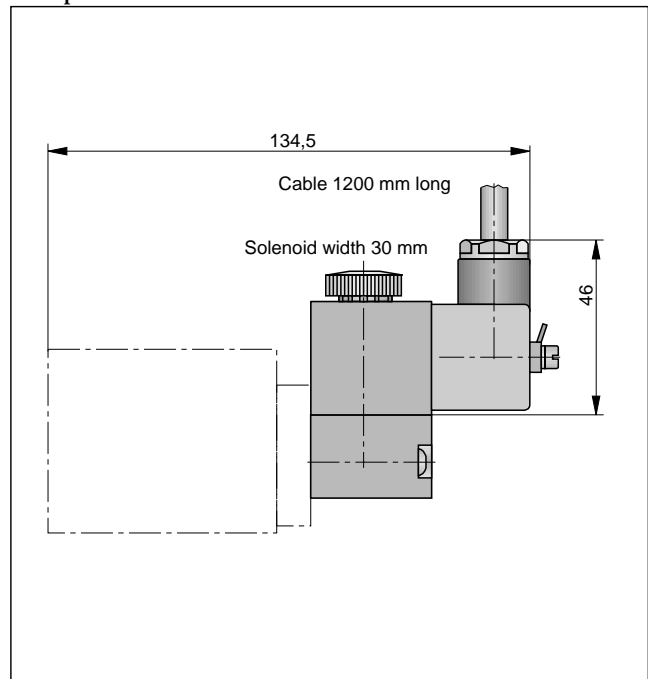

Order Instructions

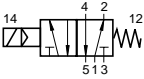
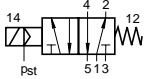
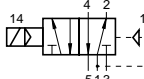
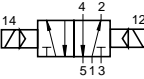
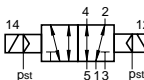
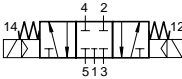
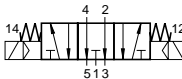
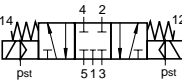
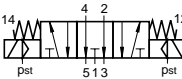
Actuation	Return	Symbol	Order Instructions	
			Type	Order No.
Electrical, by permanent signal	Spring return		S20581RF-3-..	PA 16442-...33
	with external pilot air		S20581S-RF-3-..	PA 16462-...33
Electrical, by permanent signal	Spring return (pilot operated)		S20581R-3-..	PA 16445-...33
Electrical, by impulse	Electrical, by impulse		S20581-3-..	PA 16439-...33
	with external pilot air	with external pilot air		S20581S-3-..
Electrical, by permanent signal spring return to middle position	Middle position closed		S20581RFG-3-..	PA 16463-...33
	Middle position exhausted		S20581RFE-3-..	PA 16435-...33
with external pilot air	Middle position closed		S20581S-RFG-3-..	PA 16463-...33
	Middle position exhausted		S20581S-RFE-3-..	PA 16464-...33

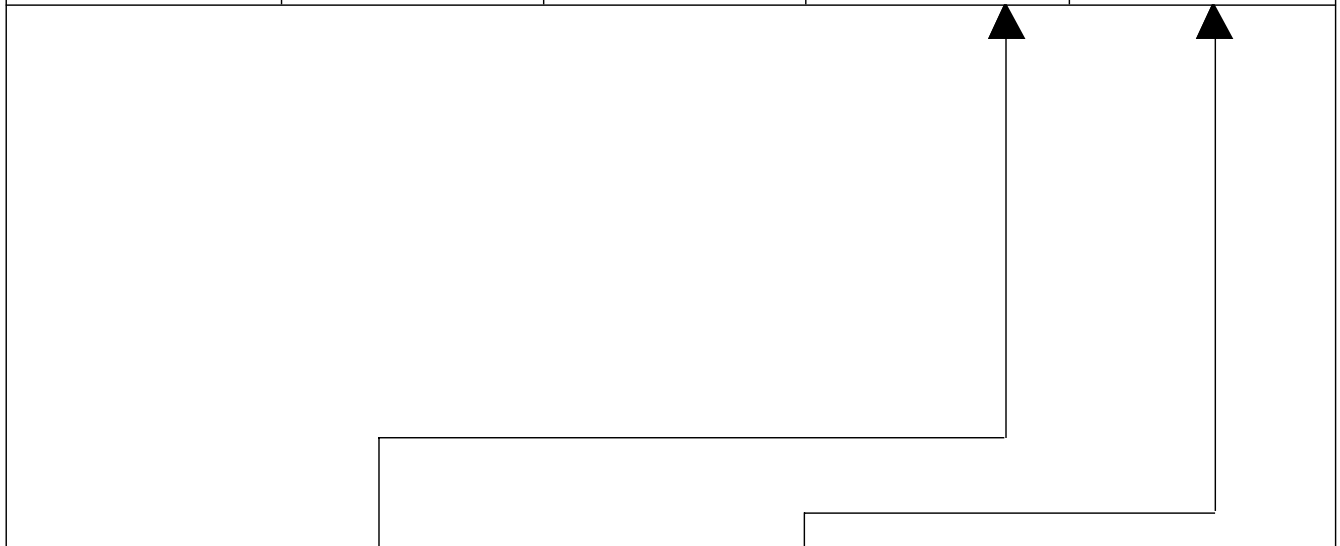

Solenoid version	Nominal voltage	Applicable for	Key code
Standard version	220 V/50 (60) Hz	110V=	61
	24 V=	48 V/50 (60) Hz	02
Low wattage version	24 V=		13
	220V/50 (60) Hz		69
Ex-proof version	24 V=		48
	220V/50 (60) Hz		98

Further voltages available on request.

5/2 and 5/3 Way Valves

to ISO 5599
Size 3

Actuation:
electrically piloted
with piezo valve
- by permanent signal
- by impulse

Series S20

S20 585-3..

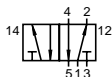

S20 585 RF.-3..

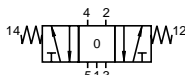

S20 585 S-RF.-3..

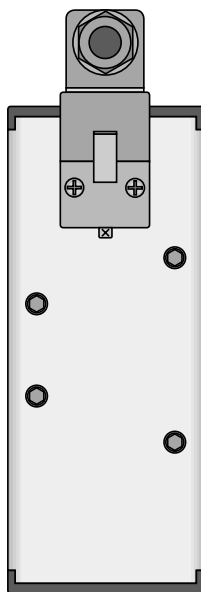
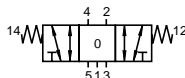

Comprises:
1 Valve with
mounting
screws
1 gasket

Characteristics to VDI 3290

Pressures quoted as gauge pressures

Characteristic	Symbol	Unit	Description		
General Features					
Type			Ceramic Spool Valve		
Mounting			On base plate to ISO 5599		
Tube connection			Base plate		
Port size			G1/2 (base plate)		
Weight (mass)		kg	1.23 permanent signal 1.37 impulse		
Installation			In any position		
Ambient temperature range	ϑ_{\min} ϑ_{\max}	°C °C	-10 +60	Note: When using below freezing	
Medium temperature range	ϑ_{\min} ϑ_{\max}	°C °C	-10 +60	point (°C) it is necessary to consult us.	
Medium			filtered air		
Lubrication			with or without oil mist lubrication ¹⁾		
Pneumatic Characteristics					
Nominal Pressure	p_n	bar	6		
Operating pressure range	p_{\min}	bar	2		
			-1 (version S)		
	p_{\max}	bar	12		
Nominal flow	Q_N	l/min	5/2 way valve	5/3 way valve	
			6660	6660	
Actuation					
Electrical			Pilot operated Pilot operated, with external pilot air		
Voltage			Universal voltage	Ex-proof	Ex-proof low voltage
Nominal voltage*	U_N	V	24-250 DC 20-230 AC	24 DC	7.5 DC ±10%
Nominal power	P_N	W	0.003 (24 V DC) 0.77 (220 V AC)	0.006	0.015
Initial current		mA	10-14	1.6	-
Continuous current		mA	0.1 (24 V DC) 3.5 (220 V AC)	0.24	2
Switching voltage	U_{on}	V	> 21.5	> 21.5	> 6
	U_{max}	V	250 DC 230 AC	30	15.5
	U_{out}	V	< 12	< 5	< 2
Duty cycle	ED	%	100 ²⁾	100 ²⁾	100 ²⁾
Electrical protection			IP54	EEx ib IIC T6	EEx ia IIC T6/T5
Connection			Plug to DIN 43650A		

* See Order Instructions for details

¹⁾ We recommend the use of mineral oil type VG32 to ISO 3448

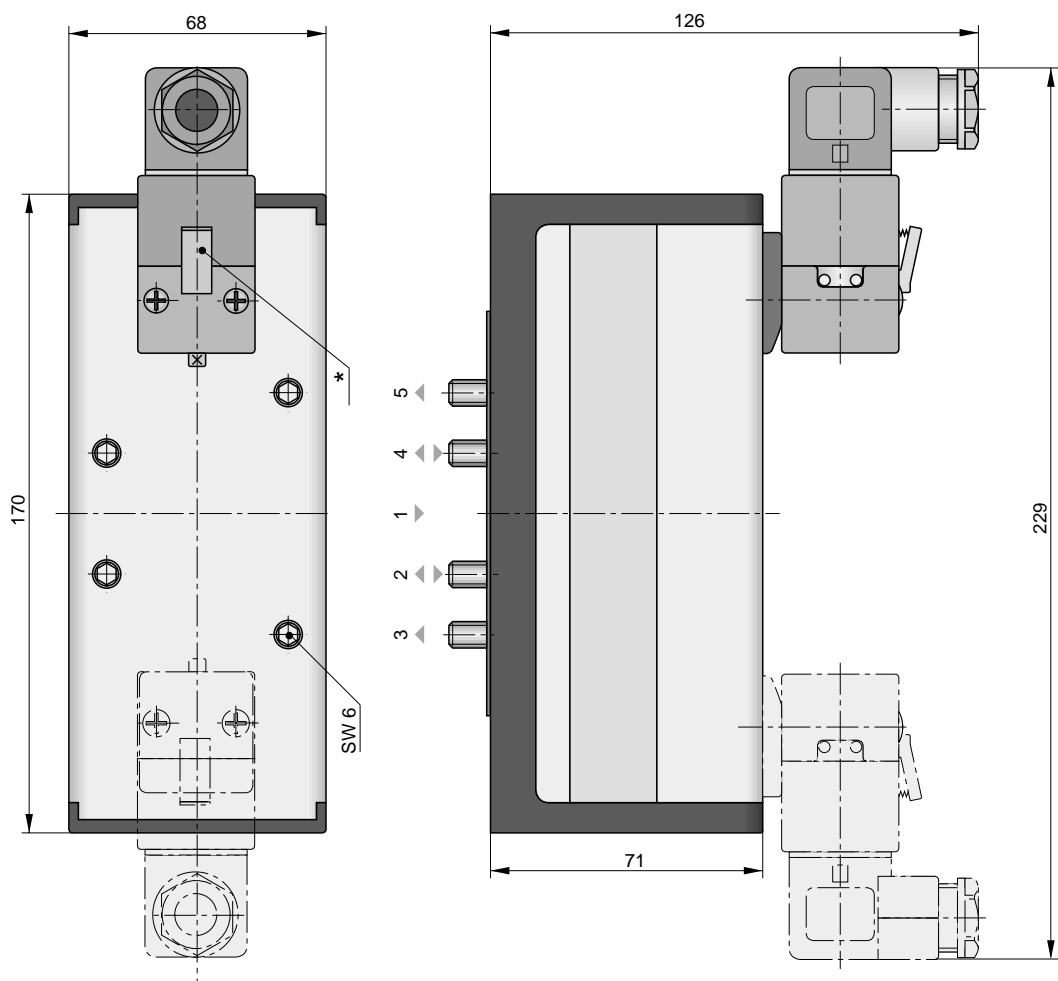

²⁾ not suited as safety valve with 100% ED

Dimensions (mm)

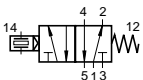
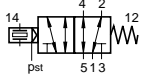
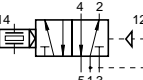
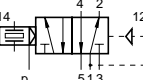
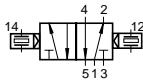
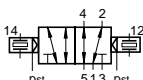
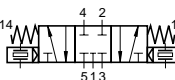

* Manual actuation

Order Instructions

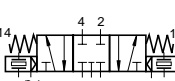
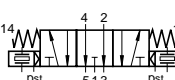
Actuation	Return	Symbol	Type	Order Instructions Order No.
Electrical, by permanent signal	Spring return		S20 585RF-3-..	PS 13744-..1A
with external pilot air	Spring return		S20 585S-RF-3-..	PS 13745-..1A
Electrical, by permanent signal	Spring return (pilot operated)		S20 585R-3-..	PS 13742-..1A
with external pilot air	Spring return (pilot operated)		S20 585S-R-3-..	PS 13743-..1A
Electrical, by impulse,	Electrical, by impulse		S20 585-3-..	PS 13740-..1A
with external pilot air	with external pilot air		S20 585S-3-..	PS 13741-..1A
Electrical, by permanent signal spring return to middle position	Middle position closed		S20 585RFG-3-..	PS 13746-..1A
	Middle position pressurized		S20 585RFE-3-..	PS 13748-..1A
with external pilot air	Middle position closed		S20 585S-RFG-3-..	PS 13747-..1A
	Middle position pressurized		S20 585S-RFE-3-..	PS 13749-..1A

Piezo Version	Nominal Voltage	Type key	Key code
Standard version	24-250VDC 20-230V AC	A *	13
	24VDCEx	E	21
		7,5VDCEx	N 51
Special version	24V DC	D	30
	Pilot-Valve with NO-function on request		

* Note:
Because of the very small power consumption, residual and leakage currents of the controlling circuit can cause unintended switching of the valve, if they are larger than the operating current.

Characteristics to VDI 3290

Pressures quoted as gauge pressure

Characteristics	Symbol	Unit	Description
General Features			
Type			Ceramic Spool Valve
Mounting			On base plate, to VDMA 24563
Tube connection			Base plate
Port size			G1/8 or G1/4 (base plate)
Weight (mass)		kg	0.32
Installation			In any position
Ambient temperature range	ϑ_{\min} ϑ_{\max}	°C °C	-10 +60 Note: When using below freezing
Medium temperature range	ϑ_{\min} ϑ_{\max}	°C °C	-10 +55 point (°C) it is necessary to consult us.
Medium			Filtered compressed air
Lubrication			With or without oil mist lubrication ¹⁾
Pneumatic Characteristics			
Nominal pressure	p_n	bar	6
Operating pressure range	p_{\min} p_{\max}	bar bar	-0.9 10
Nominal flow	Q_N	l/min	900
Actuation			
Pneumatic			Direct
Actuation pressure range	$p_{st \min}$	bar	2
	$p_{st \max}$	bar	10

¹⁾ We recommended the use of mineral oil type VG32 to ISO 3448

5/2 and 5/3 Way Valves

to VDMA 24563
Size 01

Actuation:
- pneumatic, permanent signal
- pneumatic, impulse

Series S20

S20 561RF-01
S20 561R-01
S20 561-01



S20 561RF.-01

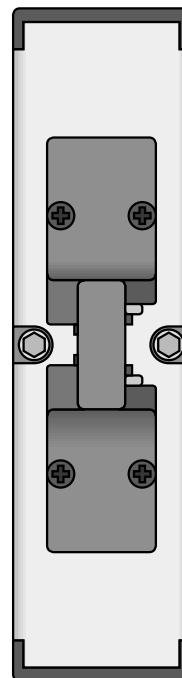
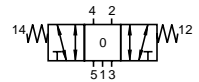

Comprises:
1 valve with
mounting
screws
1 gasket

For base plates see pages 42-45

HOERBIGER
ORIGA

Dimensions (mm)

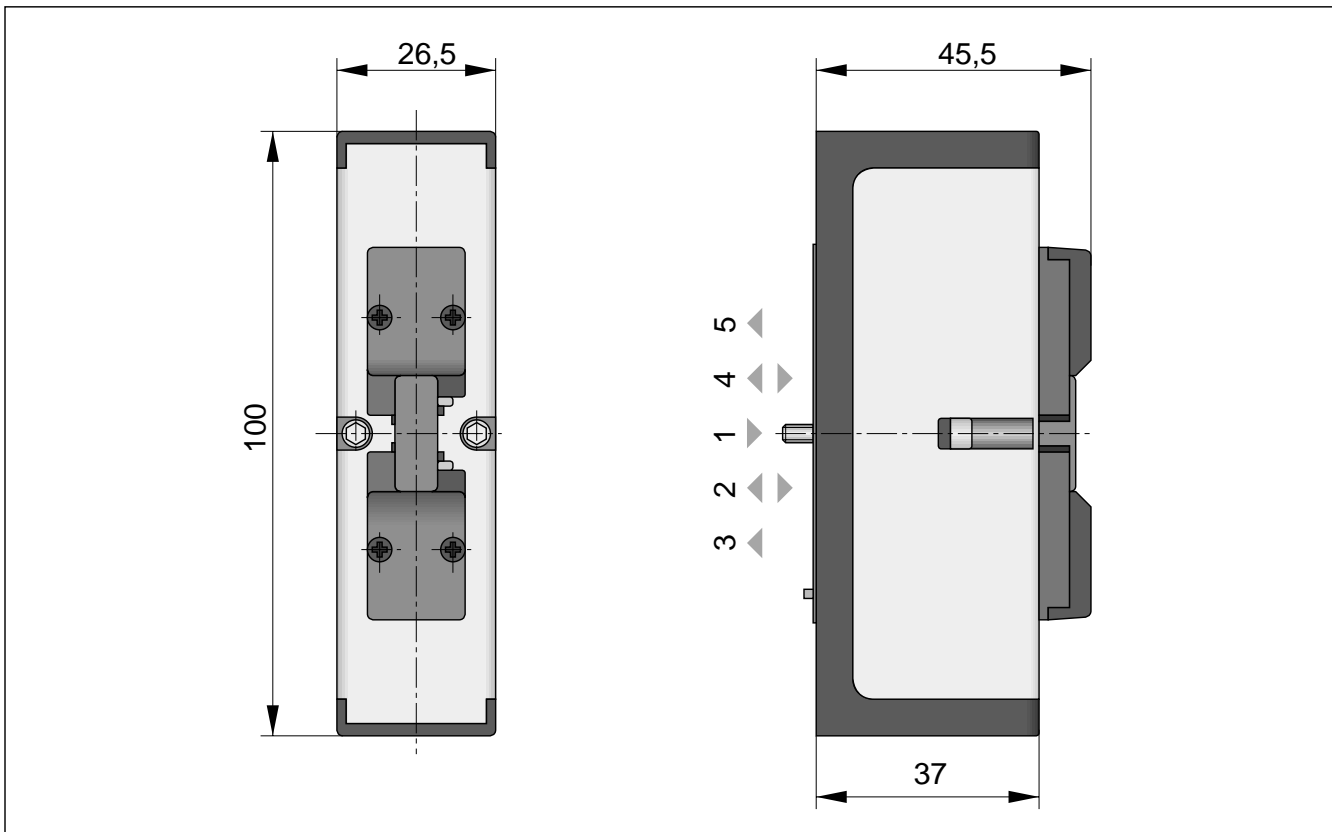

Order Instructions

Actuation	Return	Symbol	Type	Order Instructions Order No.
Pneumatic, by permanent signal	Spring return		S20561RF-01	PA 12891
Pneumatic, by permanent signal	Spring return (pilot operated)		S20561R-01	PA 12892
Pneumatic, by impulse	Pneumatic, by impulse		S20561-01	PA 12893
Pneumatic, by permanent signal spring return to middle position	Middle position closed		S20561RFG-01	PA 12894
	Middle position exhausted		S20561RFE-01	PA 12895

Characteristics to VDI 3290

Pressures quoted as gauge pressure

Characteristics	Symbol	Unit	Description
General Features			
Type			Ceramic Spool Valve
Mounting			On base plate, to VDMA 24563
Tube connection			Base plate
Port size			G1/8 or G1/4 (base plate)
Weight (mass)		kg	0.250 permanent signal 0.270 impulse
Installation			In any position
Ambient temperature range	ϑ_{\min} ϑ_{\max}	°C °C	-10 +60
Medium temperature range	ϑ_{\min} ϑ_{\max}	°C °C	-10 +55
Medium			Filtered compressed air
Lubrication			With or without oil mist lubrication ¹⁾
Pneumatic Characteristics			
Nominal pressure	p_n	bar	6
Operating pressure range	p_{\min}	bar	2
			-0.9 (Version S)
	p_{\max}	bar	10
Nominal flow	Q_N	l/min	900
Actuation			
Electrical			Pilot operated, Pilot operated with external pilot air
Actuation pressure range	$p_{st \min}$	bar	2
		$p_{st \max}$	bar
Voltage type			AC DC
Nominal voltage *	U_n	V	230 24
			Further voltages available on request
Initial power consumption		VA (W)	2 2
Duty cycle	ED	%	100
Electrical protection			IP65 to DIN 40050 (with plug)
Insulating material			F to VDE 0580
Connection			Plug to DIN 43650 form C

* See Order Instructions for details

¹⁾ We recommended the use of mineral oil type VG32 to ISO 3448

5/2 and 5/3 Way Valves

 to VDMA 24563
Size 01

Actuation:
 Electrical pilot operated
 - by permanent signal
 - by impulse

Series S20

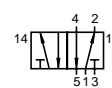
 S20581RF-01
 S20581R-01
 S20581-01
 S20581S-01

S20581 RF.-01

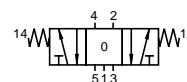

S20581 S-RF.-01

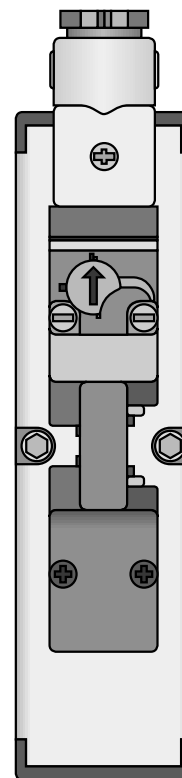
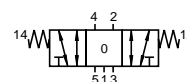

Comprises:
 1 valve with
 mounting
 screws
 1 gasket

For base plates see pages 42-45

HOERBIGER

ORIGA

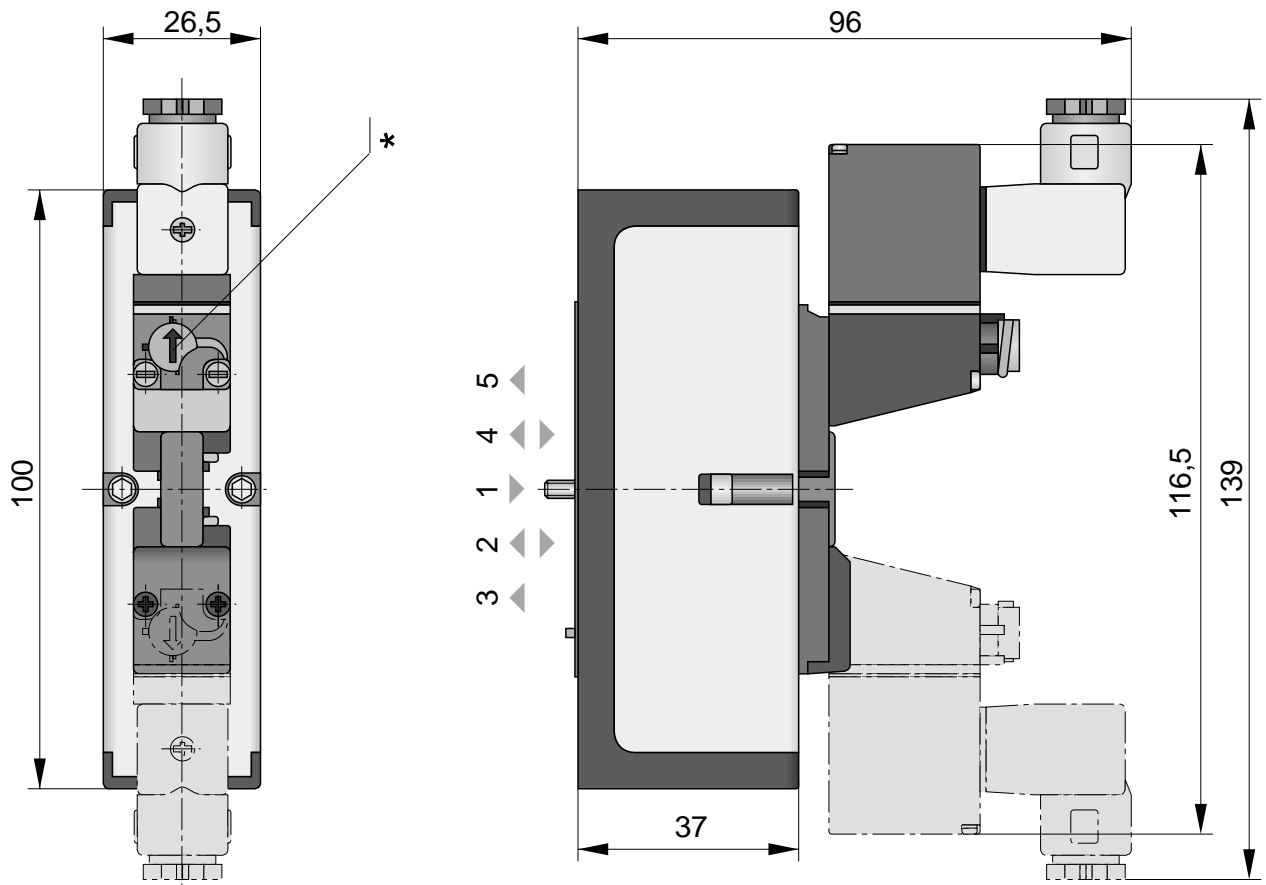
Dimensions (mm)



* Manual actuation

Order Instructions

Actuation	Return	Symbol	Order Instructions	
			Type	Order No.
Electrical, by permanent signal	Spring return		S20581RF-01-..	PA 12886-..33
	with external pilot air		S20581S-RF-01-..	PA 12896-..33
Electrical, by permanent signal	Spring return (pilot operated)		S20581R-01-..	PA 12887-..33
Electrical, by impulse	Electrical, by impulse		S20581-01-..	PA 12888-..33
	with external pilot air	with external pilot air		S20581S-01-..
Electrical, by permanent signal spring return to middle position	Middle position closed		S20581RFG-01-..	PA 12889-..33
	Middle position exhausted		S20581RFE-01-..	PA 12890-..33
with external pilot air	Middle position closed		S20581S-RFG-01-..	PA 12900-..33
	Middle position exhausted		S20581S-RFE-01-..	PA 12899-..33

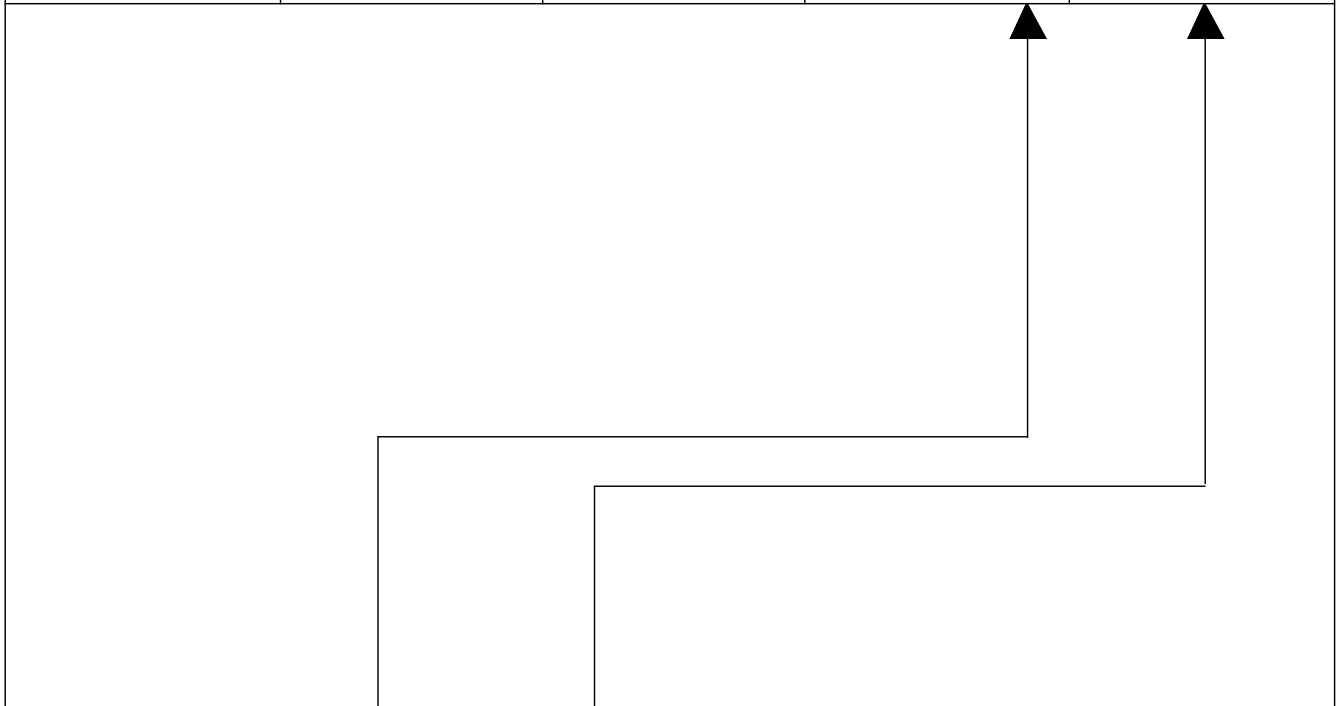

Solenoid version	Nominal voltage	Key code
Standard version	230 V/50 (60) Hz	61
	24 V=	02

Further voltages available on request.

Base Plates

to ISO 5599
 Sizes 1, 2, 3, 4

Single base plates
 - to VDMA 24345 Form A
 - to VDMA 24345 Form B

Dimensions Single Base Plate, Form A

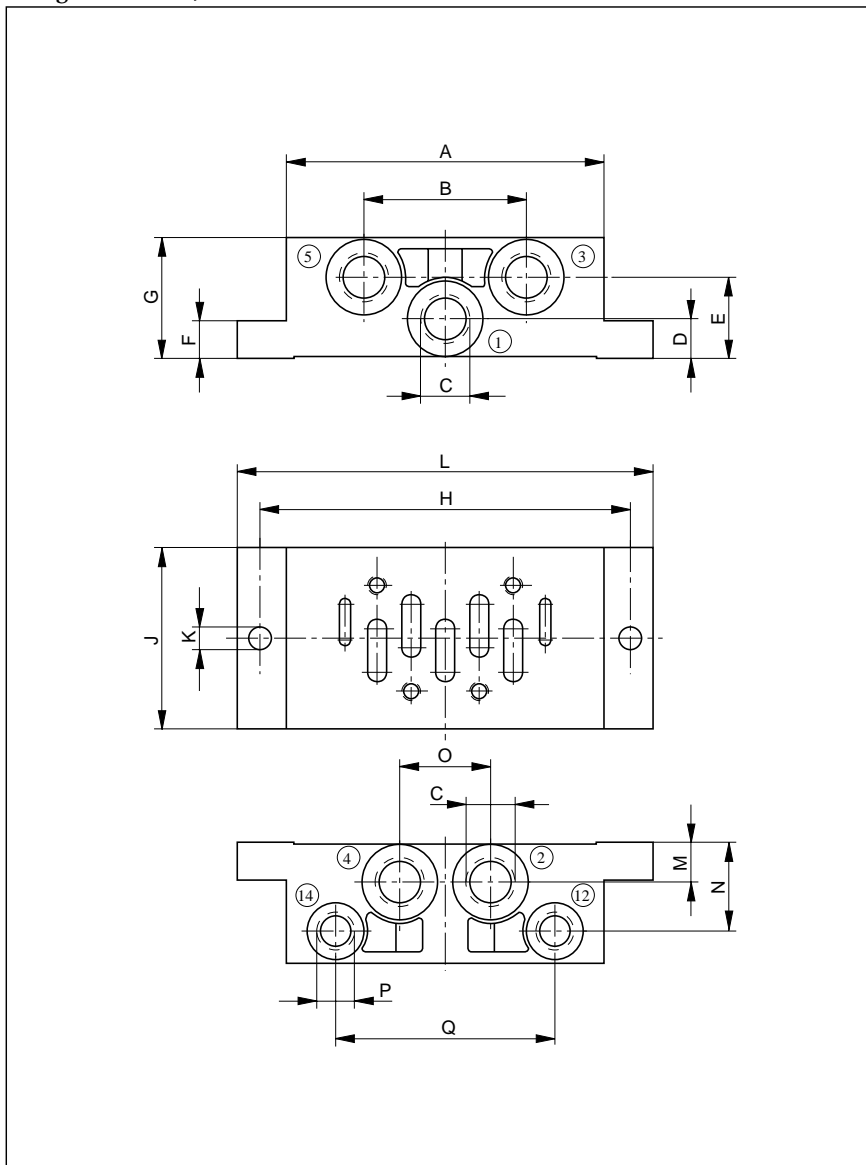

Dimensions Table (mm)

ISO Size	A	B	C	D	E	F	G	H
1	84	43	G1/4	10.5	21.5	10	32	98
2	95	56	G3/8	14	26	13	40	112
3	119	68	G1/2	17	17	18	32	136

ISO Size	J	K	L	M	N	O	P	Q
1	48	5.5	110	10.5	23.5	24	G1/8	58
2	57	6.6	124	14	30	30	G1/8	74
3	71	6.6	149	17	22	32	G1/8	90

Order Instructions

ISO Size	Type	Order Instructions Order No.
1	S9-1-A	KX 9076
2	S9-2-A	KX 9433
3	S9-3-A	KX 9434

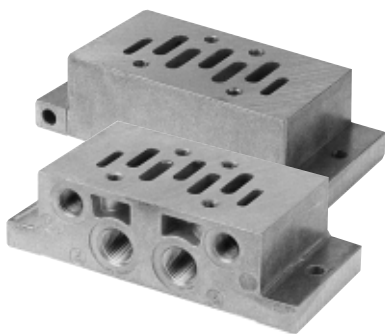

**Dimensions
Single Base Plate, Form B**

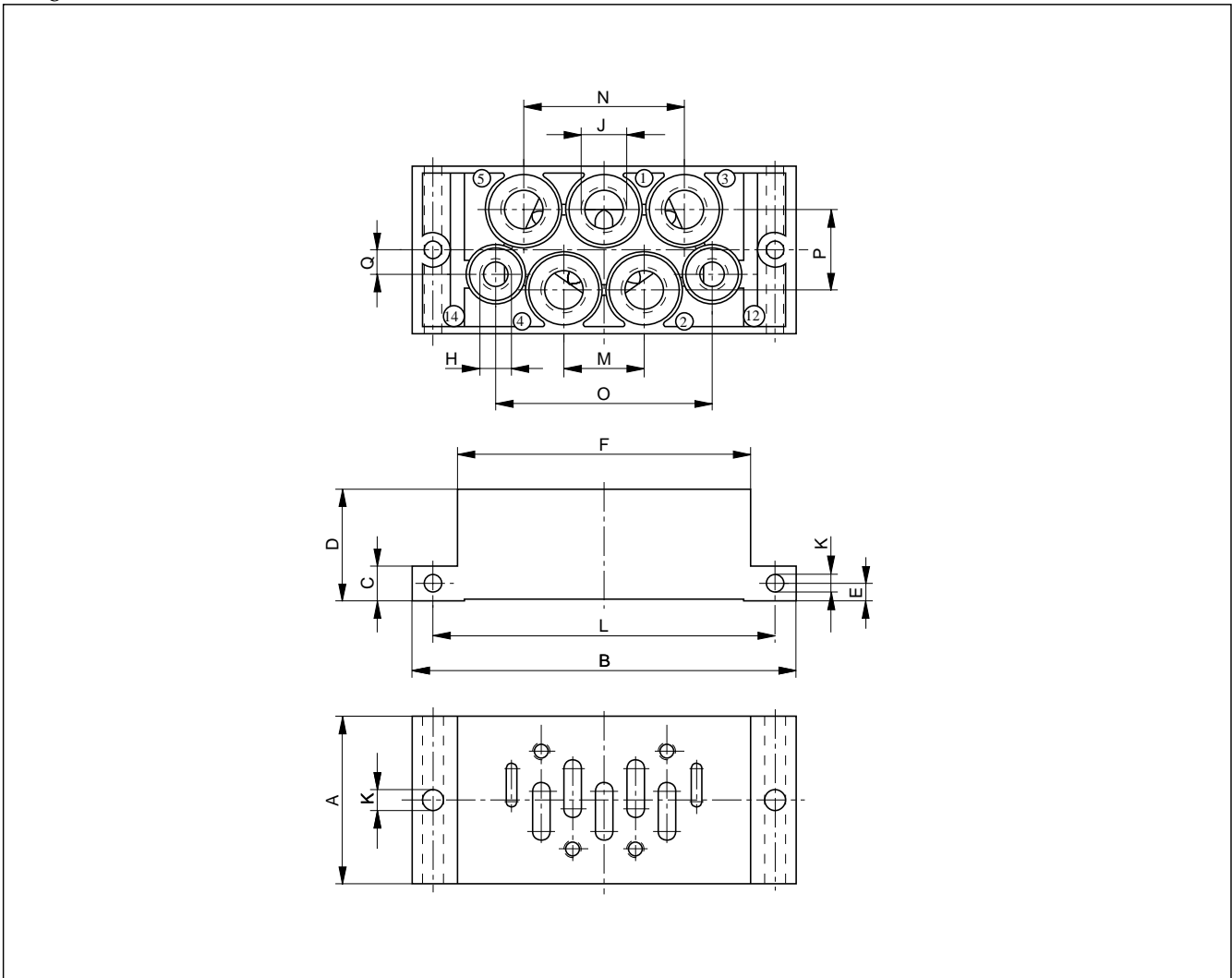

Dimensions Table (mm)

ISO Size	A	B	C	D	E	F	H	J	K	L	M	N	O	P	Q
1	46	110	10	30	5	84	G1/8	G1/4	5.5	98	23	46	62	23	7.5
2	56	124	13	35	6.5	95	G1/8	G3/8	6.6	112	28	56	73	27	7.5
3	71	149	18	32	9	119	G1/8	G1/2	6.6	136	34	68	90	35	10

Order Instructions

ISO Size	Order Instructions	
	Type	Order No.
1	S9-1-B	KX 9077
2	S9-2-B	KX 9436
3	S9-3-B	KX 9437

Base Plates

to ISO 5599
 Sizes 1, 2, 3, 4

Versions to VDMA 24345

- End plate set, Form D, to intermediate plate, Form C
- Intermediate plate, Form C
- Plate combinations of Forms C and D
- Angle base plate, Form E, for intermediate plate, Form C
- Accessories

Base Plate Combinations

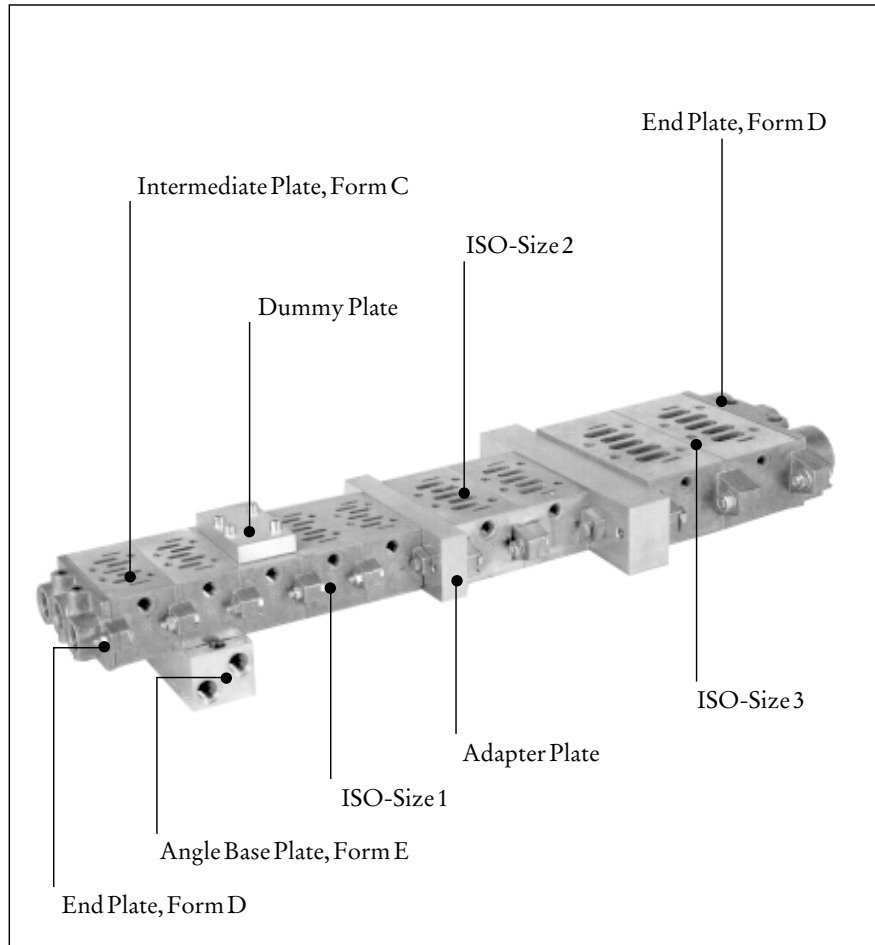

End Plate Set, Form D for Intermediate Plate



Order Instructions

ISO Size	Order Instructions	
	Type	Order No.
1	S9-1-D	KX 9078
2	S9-2-D	KX 9421
3	S9-3-D	KX 9422

Comprises:
 End plate set, complete with screws

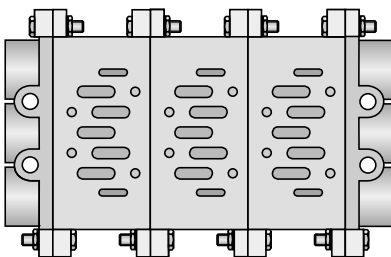

Intermediate Plate, Form C



Order Instructions

ISO Size	Order Instructions	
	Type	Order No.
1	S9-1-C	KX 9079
2	S9-2-C	KX 9419
3	S9-3-C	KX 9420

Comprises:
 Intermediate plate, complete with O-rings and screws

**Angle Base Plate, Form E,
to Intermediate Base Plate, Form C**

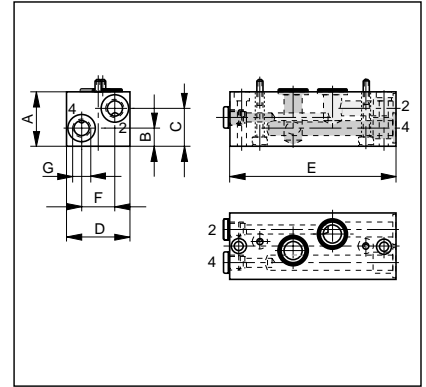

Dimensions Table (mm) and Order Instructions

Order Instructions Type	Order No.	ISO Size	A	B	C	D	E	F	G
S9-1-E	KX 9081	1	37	12	25	42	110	22	G1/4
-	-	2	-	-	-	-	-	-	-
S9-3-E	KX 9425	3	45	17	29	70	190	36	G1/2

Comprises: Angle base plate, complete with O-rings and screws

**Adapter Plate for combining
ISO Sizes 1, 2, 3**

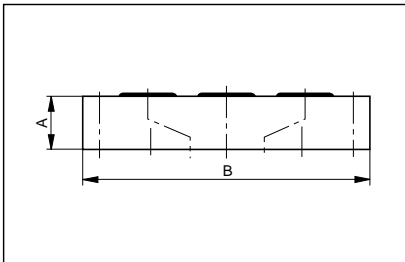

Dimensions Table (mm) and Order Instructions

Order Instructions Type	Order No.	For ISO Size	A	B	Width
S9-1-2-KP	KX 9430	1 on 2	20	135	45
S9-2-3-KP	KX 9431	2 on 3	25	190	55
S9-1-3-KP	KX 9432	1 on 3	35	190	50

Comprises: Adapter plate with O-rings and screws

Dummy Plate

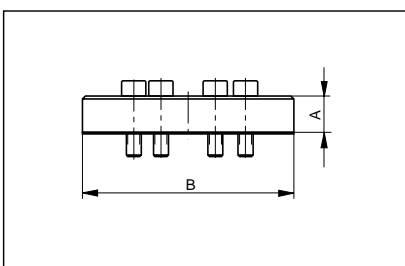

Dimensions Table (mm) and Order Instructions

Order Instructions Type	Order No.	ISO Size	A	B	Width
S9-1-BP	KX 9082	1	12	70	40
S9-2-BP	KX 9423	2	12	90	55
S9-3-BP	KX 9424	3	12	110	70

Comprises: Dummy plate with gasket and screws

Plug

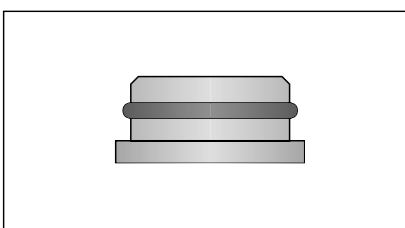

Order Instructions

Order Instructions Type	Order No.	For ISO Size
S9-1-VS	KX 5789	1
S9-2-VS	KX 9426	2
S9-3-VS	KX 9427	3

Base Plate Combinations of Forms C and D

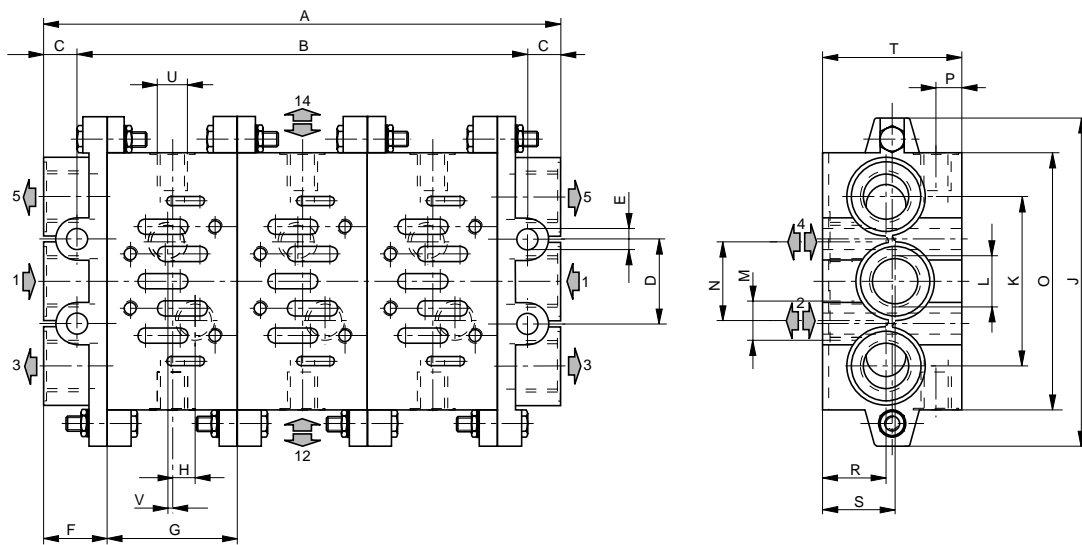

Shown: 3-fold plate combinations

Dimensions Table (mm)

ISO Size	Number of Plates	A	B	C	D	E	F	G	H	J	K
1	2	130	108	11	28	Ø7	22	43	7.5	110	56
1	3	173	151	11	28	Ø7	22	43	7.5	110	56
1	4	216	194	11	28	Ø7	22	43	7.5	110	56
1	5	259	237	11	28	Ø7	22	43	7.5	110	56
1	6	302	280	11	28	Ø7	22	43	7.5	110	56
2	2	164	138	13	35	Ø9	26	56	6	135	68
2	3	220	194	13	35	Ø9	26	56	6	135	68
2	4	276	250	13	35	Ø9	26	56	6	135	68
2	5	332	306	13	35	Ø9	26	56	6	135	68
2	6	388	362	13	35	Ø9	26	56	6	135	68
3	2	202	172	15	52	Ø12	30	71	8	190	104
3	3	273	243	15	52	Ø12	30	71	8	190	104
3	4	344	314	15	52	Ø12	30	71	8	190	104
3	5	415	385	15	52	Ø12	30	71	8	190	104
3	6	486	456	15	52	Ø12	30	71	8	190	104

ISO-Size	Number of Plates	L	M	N	O	P	R	S	T	U	V
1	2	G3/8	G1/4	26	85	8.5	21	24	46	G1/8	1.5
1	3	G3/8	G1/4	26	85	8.5	21	24	46	G1/8	1.5
1	4	G3/8	G1/4	26	85	8.5	21	24	46	G1/8	1.5
1	5	G3/8	G1/4	26	85	8.5	21	24	46	G1/8	1.5
1	6	G3/8	G1/4	26	85	8.5	21	24	46	G1/8	1.5
2	2	G1/2	G3/8	30	100	9	22	24	47	G1/8	5
2	3	G1/2	G3/8	30	100	9	22	24	47	G1/8	5
2	4	G1/2	G3/8	30	100	9	22	24	47	G1/8	5
2	5	G1/2	G3/8	30	100	9	22	24	47	G1/8	5
2	6	G1/2	G3/8	30	100	9	22	24	47	G1/8	5
3	2	G1	G1/2	38	140	10	31	34	56	G1/8	6
3	3	G1	G1/2	38	140	10	31	34	56	G1/8	6
3	4	G1	G1/2	38	140	10	31	34	56	G1/8	6
3	5	G1	G1/2	38	140	10	31	34	56	G1/8	6
3	6	G1	G1/2	38	140	10	31	34	56	G1/8	6

Order Instructions for Base Plate Combinations

Description	ISO Size	Order Instructions	
		Type	Order No.
Plate combination for 2 valves	1	S9-1-002	PD 30076-0002
	2	S9-2-002	PD 32951-0002
	3	S9-3-002	PD 32952-0002
Plate combination for 3 valves	1	S9-1-003	PD 30076-0003
	2	S9-2-003	PD 32951-0003
	3	S9-3-003	PD 32952-0003
Plate combination for 4 valves	1	S9-1-004	PD 30076-0004
	2	S9-2-004	PD 32951-0004
	3	S9-3-004	PD 32952-0004
Plate combination for 5 valves	1	S9-1-005	PD 30076-0005
	2	S9-2-005	PD 32951-0005
	3	S9-3-005	PD 32952-0005
Plate combination for 6 valves	1	S9-1-006	PD 30076-0006
	2	S9-2-006	PD 32951-0006
	3	S9-3-006	PD 32952-0006

Plate combinations made up to customer's requirements on request

Accessories

Adapter plate for pressure switch*	1	S9-1-DR	KX 9293
	2	S9-2-DR	KX 9428
	3	S9-3-DR	KX 9429
Adapter plate with built-in pressure regulator	1	S9-1-RE	PD 31826
	3	S9-3-RE	PD 33098

* Pressure switches available on request

Base Plates

to VDMA
Sizes 01

Single baseplates
- to VDMA 24345 Form A

Port Size G1/8, G1/4

Dimensions
Single Base Plate, Form A – Port Size G1/8

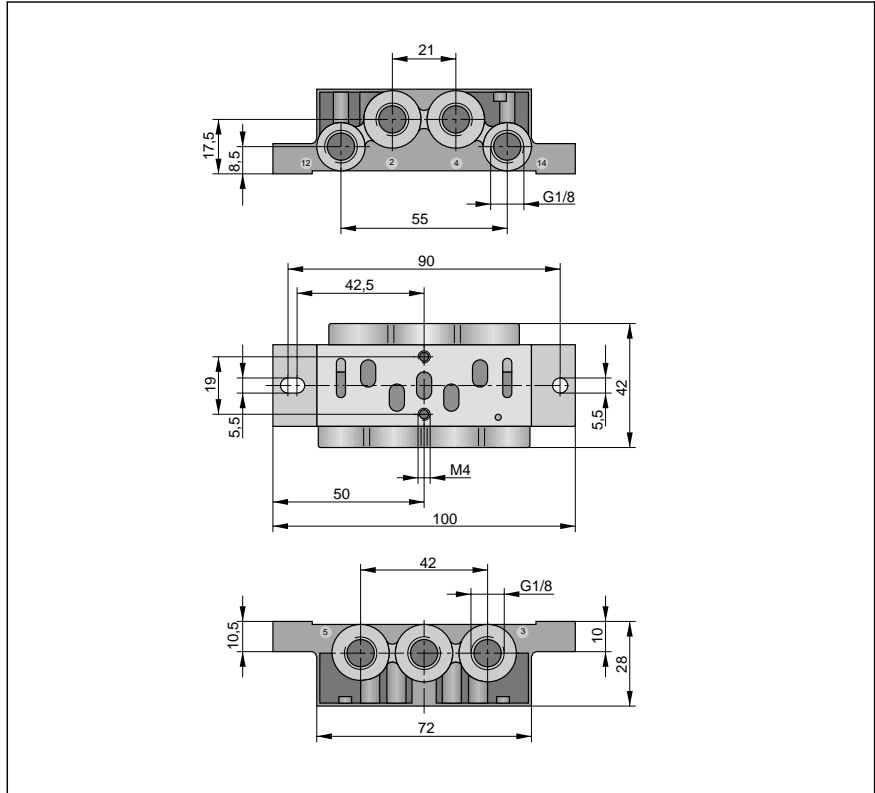

Order Instruction: Type S20-01-1/8-A Order No. KL8004

Dimensions
Single Base Plate, Form A – Port Size G1/4

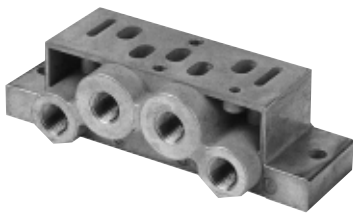
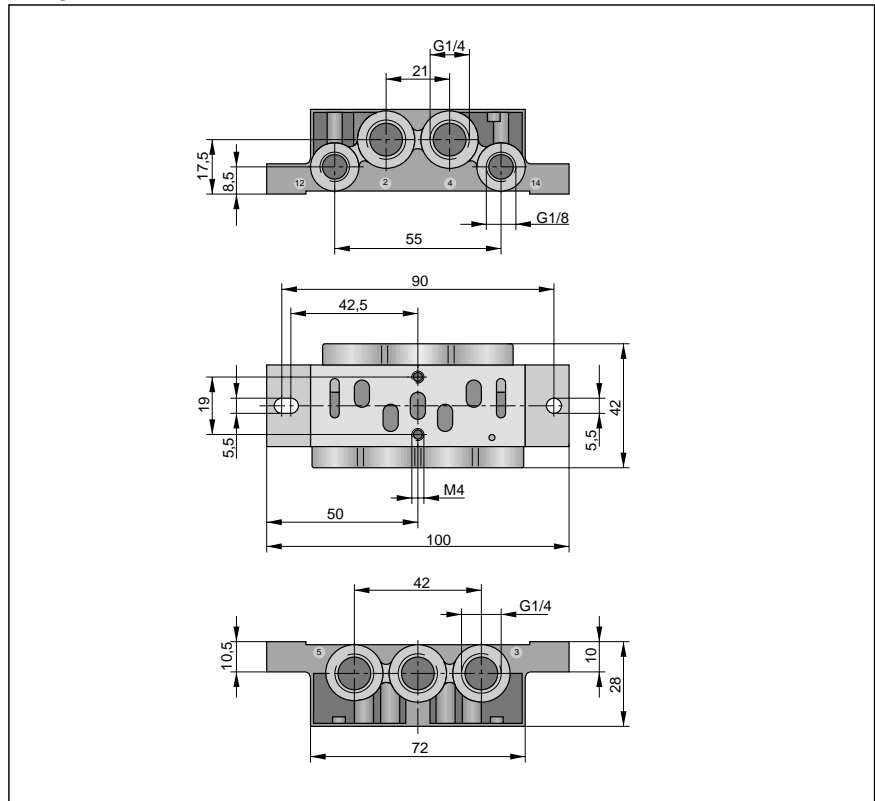

Order Instruction: Type S20-01-1/4-A Order No. KL8005

**End Plate Set, Form D
for Intermediate Plate**



Order Instructions

VDMA Size	Order Instructions	
	Type	Order No.
01	S20-01-D	KL 8008

Comprises:
End plate set, complete with screws

Base Plates

to VDMA Sizes 01

**Module for Base Plate Combinations
to VDMA 24345**

- End plate set, Form D,
to intermediate plate, Form C
- Angle base plate, Form E,
for intermediate plate, Form C
- Accessories

Port Size G1/8, G1/4

Intermediate Plate, Form C

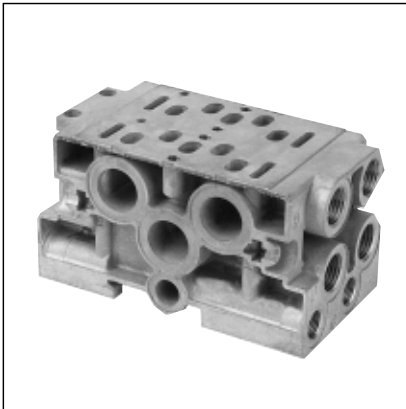

Order Instructions

VDMA Size	Order Instructions	
	Type	Order No.
01 (G1/8)	S20-01-C	KL 8006
01 (G1/4)	S20-01-C	KL 8007

Comprises:
Intermediate plate, complete with
O-rings and screws

Dummy Plate

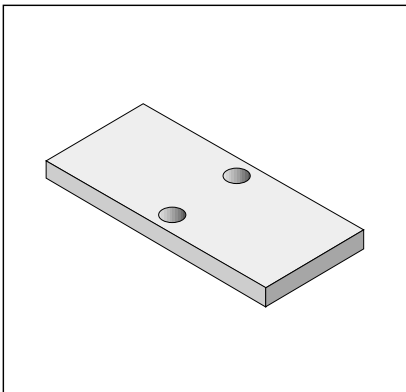

Order Instructions

VDMA Size	Order Instructions	
	Type	Order No.
01	S20-01-BP	KL 8009

Comprises: Dummy plate with gasket
and screws

Pressure module with gasket

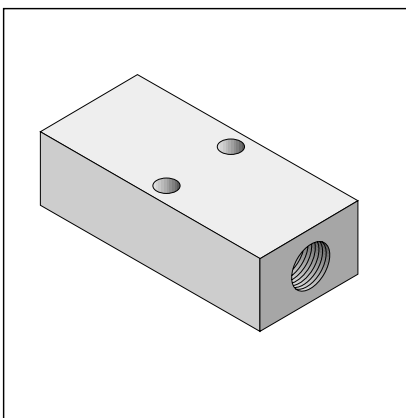

Order Instructions

VDMA Size	Order Instructions	
	Type	Order No.
01	S20-01-DM	KL 8010

Comprises:
Pressure module with gasket

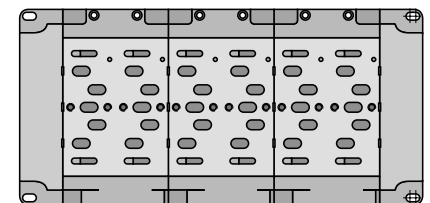

Dimensions (mm)
 Base Plate Combinations of Forms C and D – Port Size G1/8

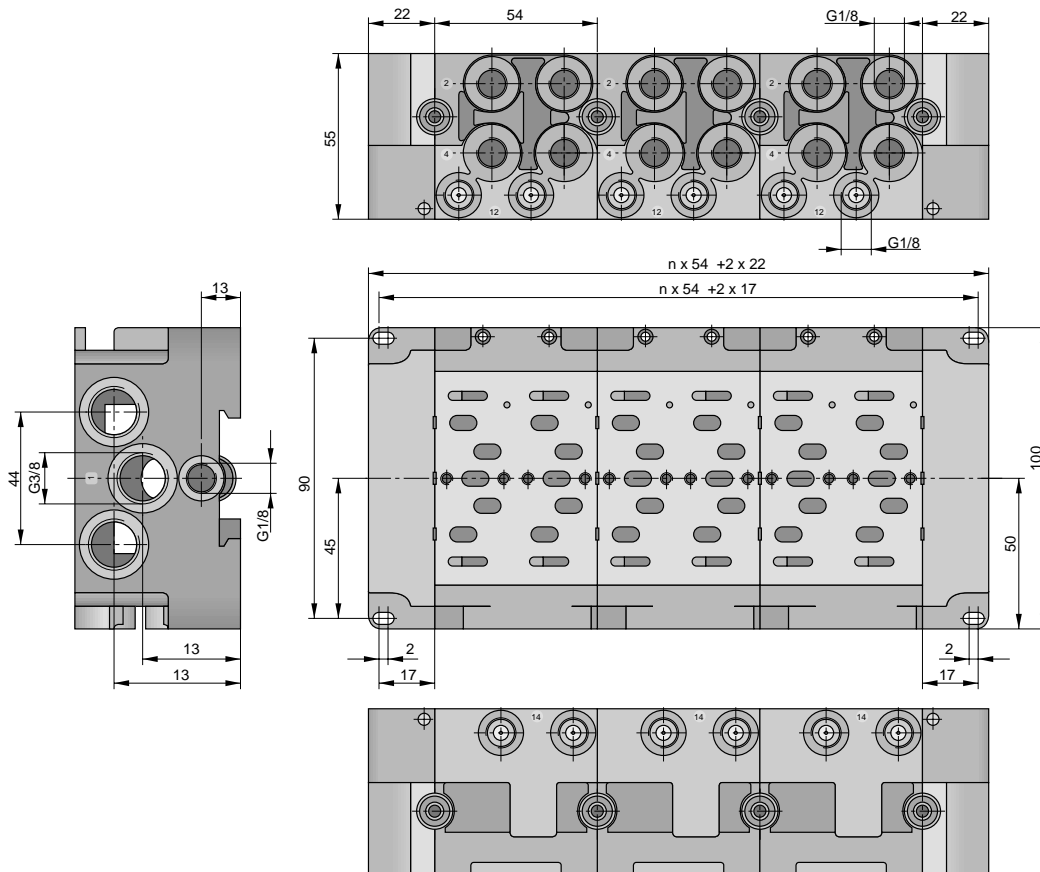

n = number of base plates

Dimensions (mm)
Base Plate Combinations of Forms C and D – Port Size G1/4

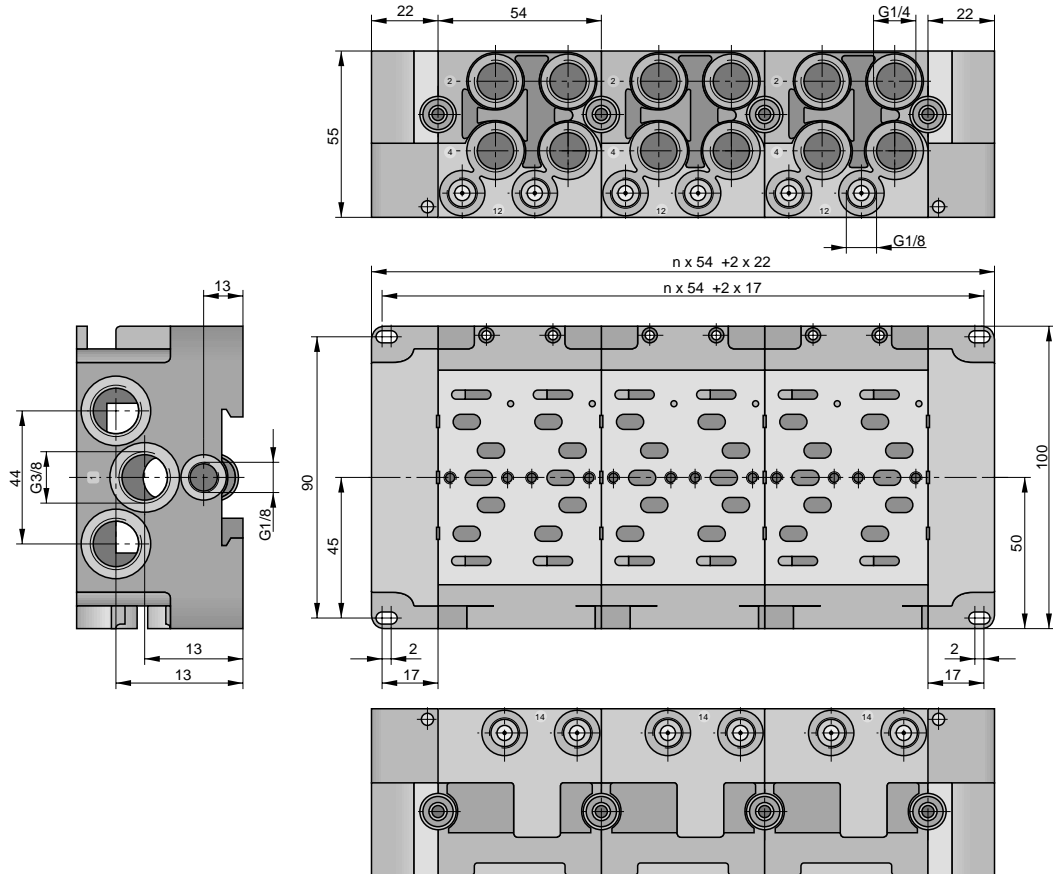

n = number of base plates

Order Instructions for Base Plate Combinations

Description	Port Size	Number of Valves	Order Instructions	
			Type	Order No.
Plate combination	G1/8	2	S20-1/8-002	PD 43963-0002
		4	S20-1/8-004	PD 43963-0004
		6	S20-1/8-006	PD 43963-0006
	G1/4	2	S20-1/4-002	PD 43964-0002
		4	S20-1/4-004	PD 43964-0004
		6	S20-1/4-006	PD 43964-0006

The valve section shows the unique combination of Piezo technology, precision engineering and electronics watchmaking and electronics.

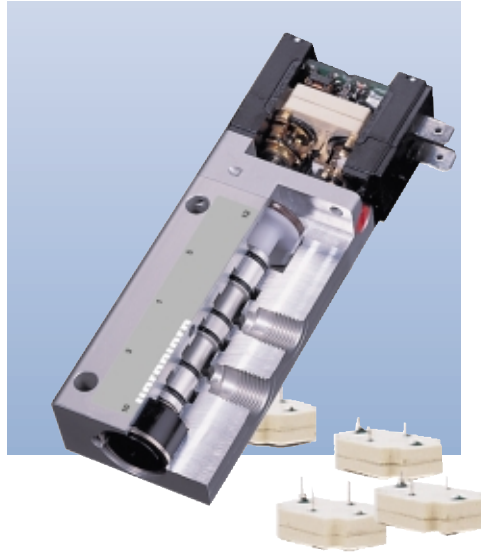

Piezo interface,
the ideal valve operator:
Extremely compact
Fast response
Very low energy consumption
Practically wear-free
Digital or analogue operation
No heat generation

PIEZO TECHNOLOGY PILOT OPERATORS FOR ISO AND IN-LINE VALVES.

... intrinsically safe valves for easy installation and exceptional reliability, particularly for the process industry, medical industry, automotive industry, laboratory applications, etc.



The right to introduce technical modifications is reserved



HOERBIGER-ORIGA GmbH · Südliche Römerstraße 15 · D-86972 Altenstadt · Tel. +49 +8861 221-0 · Fax +49 +8861 221-1305 · E-mail pneu@hoerbiger.de
HOERBIGER-ORIGA LTD. · Tewkesbury Industrial Estate · Tewkesbury GL20 8ND, GB · Tel. +44+1684 850000 · Fax +44+1684 850555 · E-mail marketing@hoerbiger-origa.com
HOERBIGER-ORIGA Pneumatik GMBH · Johann-Giefing-Str. 12 · A-2700 Wiener Neustadt · Tel.+43 +2622 26071 · Fax +49 +2622 26071-5 · E-mail amarket@hoerbiger-origa.com
HOERBIGER-ORIGA AB · Box 67 · S-73622 Kungsör · Tel. +46 +227 411 00 · Fax +46 +227 411 29 · E-mail semarket@hoerbiger-origa.com
Internet <http://www.hoerbiger-origa.com>
A3P127E611Y10X-12/98