



Features

- Single and Multiple Tube
- Variety of Colors
- Coil Tubing Available
- Several Sizes to accommodate Pneumadyne fittings

Performance Data

Temperature Range	Vacuum	Media	Diameter Tolerances
-40° to 160° F -28° to 71° C	to 28" Hg	Fluids Compatible w/ Materials	±.005

Polyurethane Tubing

Single Tubing

Pneumadyne offers Ether based Polyurethane (PU) Tubing. Material characteristics include minimal water absorption, high flexibility and opaque color pigments. The extrusion process and exclusive formulation produces a high quality tubing and eliminates surface stickiness.

85A Durometer tubing is flexible enough to make tight bends without kinking and is designed to work with *mini-barb fittings*. The materials outstanding memory provides a tight grip requiring no clamping up to 100 psi.

95A Durometer tubing is a slightly harder compound that increases wall rigidity to enable it to work with most brands of *push-to-connect* pneumatic fittings. It offers outstanding toughness and significantly higher working pressures, yet sacrifices very little flexibility.

Product Group	OD/ID	Package	Durometer	Working Pressure psi @ 75°	Standard Colors
PU-125-*		250' box			
PU-125-*-R		500' reel			0, 2, 3, 4,
PU-125-*-LR	1/8 X 1/16	1000' reel	85A	130	5, 6, 7, 8,
PU-125-*-XR		2500' reel			9, 11
PU-250-*		100' box			
PU-250-*-R	1/4 X 1/8	500' reel	85A	126	0, 2, 3, 4, 5,
PU-250-*-LR		1000' reel			6, 7, 8, 9
PU-156-*		100' box			
PU-156-*-R	5/32 X 5/64	500' reel	85A	136	0, 2, 3, 4,
PU-156-*-LR		1000' reel			5, 6, 7
PU-125F-*	1/8 X 1/16	250' box	95A	233	0, 2, 3, 4, 5, 6, 7
PU-156F-*	5/32 X 3/32	100' box	95A	176	0, 2, 3, 4, 5, 6, 7
PU-250F-*	1/4 X .160	100' box	95A	148	0, 2, 3, 4, 5, 6, 7





* See **Product Number Diagram** for Color Code information

All dimensions and specifications are subject to change without notice

Multi-Bore Tubing

Extruded Polyurethane

Multi-bore tubing is two or more tubes that are extruded as a single piece. The tubes are joined with a tough connecting web. This tubing is ideal for applications that encounter severe or constant flexing which might separate the bond on MCR tubing assemblies. A small rib runs the length of one of the tubes for easy identification. All Multi-Bore tubing is mono-colored and is recommended for use with barbed fittings. Push-in fittings are not recommended, the slightly flat surface resulting from stripping may affect the fittings sealing abilities.







Product Group	OD/ID	Package	Durometer	Working Pressure psi@ 75°	Standard Colors
					
PU2-125*-C	1/8 X 1/16	100' box	90A	130	0,2
PU2-250*-C	1/4 X 1/8	100' box	85A	126	
					
PU3-125*-C	1/8 X 1/16	100' box	85A	130	0,2
PU3-250*-L	1/4 X 1/8	50' box	85A	126	
					
PU4-125*-C	1/8 X 1/16	100' box	85A	130	0,2
PU4-250*-L	1/4 X 1/8	50' box	85A	126	
					
PU6-125*-L	1/8 X 1/16	50' box	85A	130	0,2
PU6-250*-L	1/4 X 1/8	50' box	85A	126	

* See **Product Number Diagram** for Color Code information

Multi-Color Ribbon (MCR)

85A Durometer Bonded Polyurethane

Multiple Color Ribbon (MCR) color codes your tubing lines. Great for identification, tracing or trouble shooting, this tubing will withstand the rigors of flexing and rough handling. A unique heat bonding process allows you to easily hand separate the tubing for routing.

Product Group	OD/ID	Pkg	Working Pressure psi @ 75°	Standard Colors
PUMC4-125-M		100' box		26, 28, 29, 25
PUMC4-125-2	1/8 X 1/16	100' box	130	2, 2, 2, 2
PUMC4-125-8		100' box		8, 8, 8, 8
PUMC4-125-0		100' box		0, 0, 0, 0
				
PUMC6-125-M	1/8 X 1/16	100' box	130	5, 4, 3, 6, 7, 11
PUMC6-125-2		100' box		2, 2, 2, 2, 2, 2
PUMC6-125-0		100' box		0, 0, 0, 0, 0, 0
				
PUMC8-125-M	1/8 X 1/16	100' box	130	9, 8, 32, 27, 26, 28, 29, 25
PUMC8-125-2		100' box		2, 2, 2, 2
PUMC8-125-0		100' box		0, 0, 0, 0
				
PUMC4-250-M	1/4 X 1/8	100' box	126	26, 28, 29, 25
PUMC4-250-2		100' box		2, 2, 2, 2
PUMC4-250-0		100' box		0, 0, 0, 0
				
PUMC6-250-M	1/4 X 1/8	100' box	126	5, 4, 3, 6, 7, 11
PUMC6-250-2		100' box		2, 2, 2, 2, 2, 2
PUMC6-250-0		100' box		0, 0, 0, 0, 0, 0
				
PUMC8-250-M	1/4 X 1/8	100' box	126	9, 8, 32, 27, 26, 28, 29, 25

● See **Product Number Diagram** for Color Code information

Product Group	OD/ID	Package	Durometer	Working Pressure psi @ 75°	Standard Colors
PUC-125-*	1/8 X 1/16 x 10'	1	85A	130	0, 2, 4, 27
PUC-250-*	1/4 X 1/8 X 10'	1	85A	126	0, 2, 4, 5, 6, 8
○○					
PUC2-125-*	1/8 X 1/16 x 7'	1	90A	130	2
PUC2-250-*	1/4 X 1/8 X 10'	1	85A	126	0, 2

* See **Product Number Diagram** below for Color Code information

Polyurethane Coils

Polyurethane has outstanding memory and flexibility which make it the ideal material for processing into self-storing coiled tubing. These coils are extraordinarily tough and resistant to abrasion, over-stretching and kink damage. Pneumadyne offers coils in every size and configuration of polyurethane in single, multi-tube and even jacketed bundles (contact factory for styles not listed).

Product Number Diagram Tubing

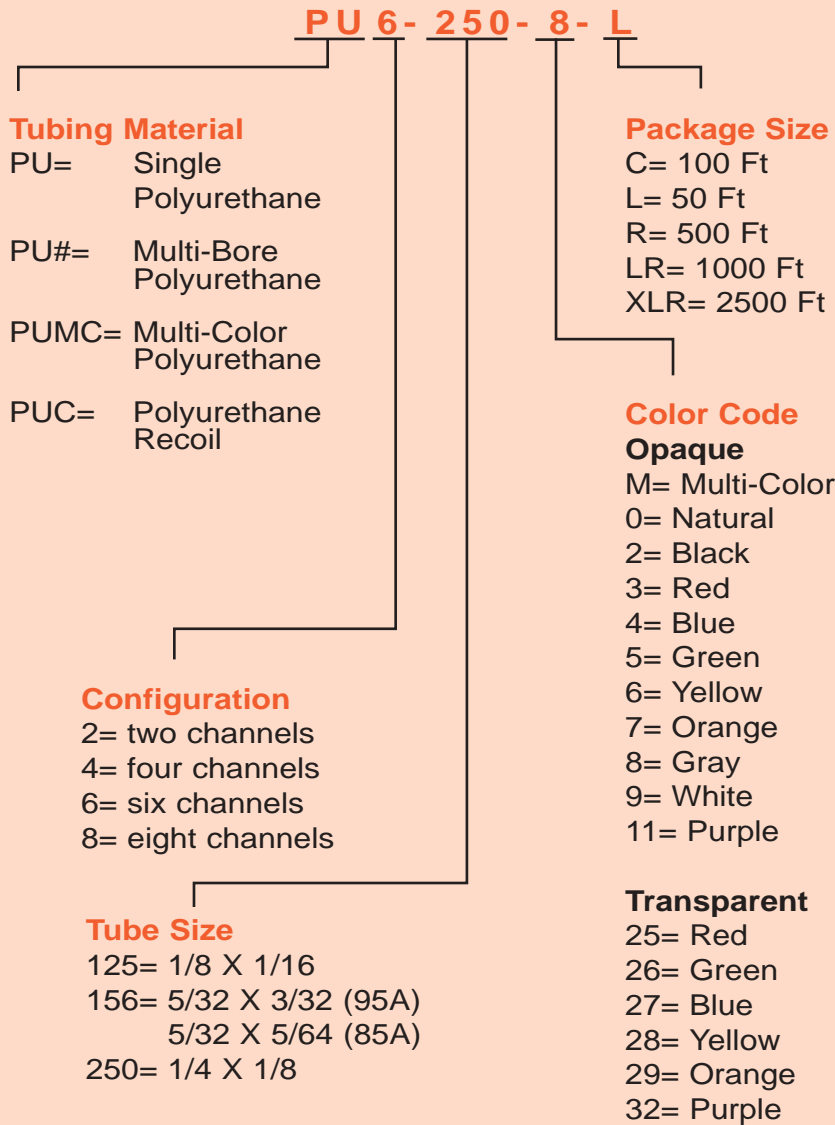

● Please use **Product Diagram** to interpret part numbers - (do not attempt to build part numbers) see **Product Information** for part number listing.

Tube Racks

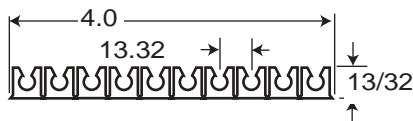

Product Group	Tubing OD	Description	Standard Colors
MTR-250-10-*	1/4	non-adhesive	2, 3, 4, 5, 6, 7, 8 & 9
MTR-250-11-*	1/4	adhesive	2, 3, 4, 5, 6, 7, 8 & 9
MTR-187-10-*	3/16	non-adhesive	2
MTR-187-11-*	3/16	adhesive	2
MTR-156-10-*	5/32	non-adhesive	2
MTR-156-11-*	5/32	adhesive	2

* Please refer to Color Code information (page 91)

Tube racks are available with 10 channels. The molded design makes them easy to customize, simply hand separate down to single holders. Select tube rack with adhesive fastener or use No. 4 machine screws for mounting.

Tube Cutter



Product Number	Description
TC-1000	Tube Cutter
TCR	Blade Replacement

Precision cutter makes quick, clean and square cuts on all plastic tubing materials.

Dispenser Box



The handy dispenser pack allows an easy method for maintaining tubing in a neat, storable package. All 100' and 250' lengths of tubing are sold in boxes with product number and color information label.

All dimensions and specifications are subject to change without notice