

Applications

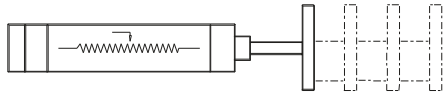

Positioning

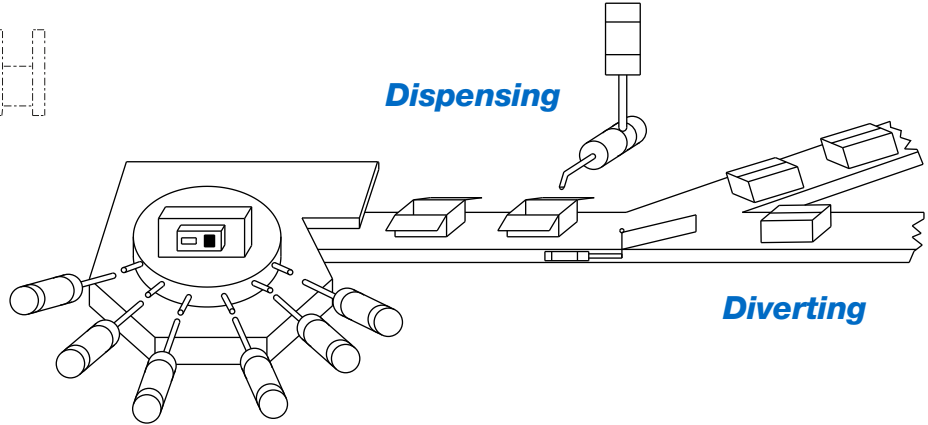

Dispensing

Diverting

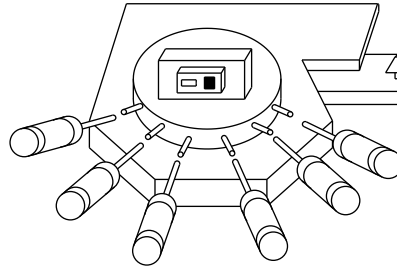

Inspection

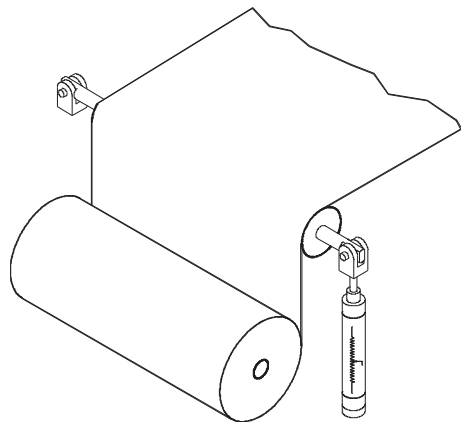

Web Guide

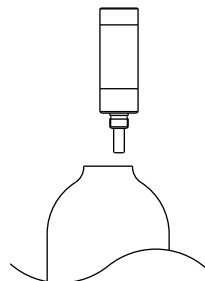
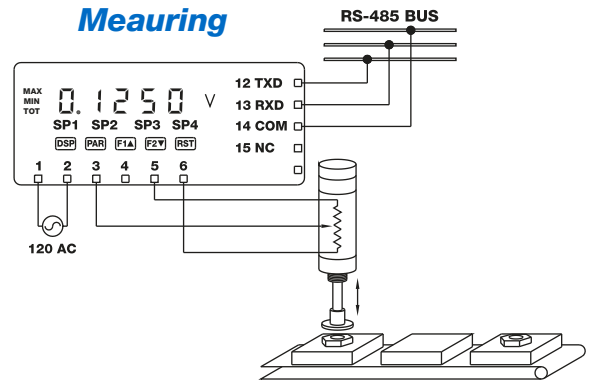

Verification

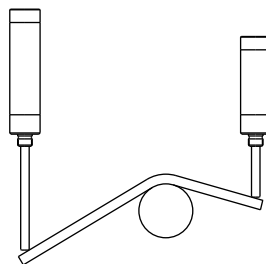

Process Acceptance

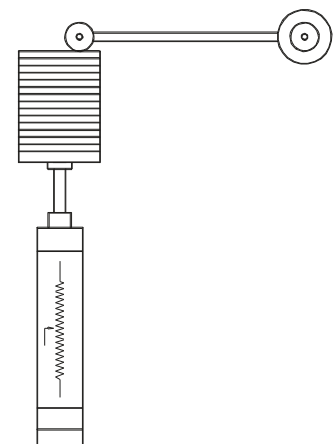

Stacker

Table of Contents

| | |
|--|-------|
| Flow Controls | 4-8 |
| Alignment Couplers | 9 |
| Position Feedback Cylinder, Model PFC | 10-19 |
| Position Feedback PneuTurn, Model PTF | 20-28 |
| Pneumatic Control System, Model PCS | 29-38 |
| Digital Panel Meter, Model DPM | 39-44 |
| Electronic Controller | 45-47 |

CAD Drawings

2D CAD drawings of all Bimba Products are available at www.bimba.com.

3D CAD drawings are also available at www.bimba.com.

Product and catalog updates can be down loaded from www.bimba.com.

For Technical Assistance: 800-44-BIMBA (800-442-4622)
(United States, Mexico & Canada)

Catalog Overview

This catalog contains Bimba's Position Feedback Products. These products are ideal for applications that require increased flexibility and adaptability. They are perfect for automated assembly processes that require quick changeovers or for mass customized product assembly.

The Position Feedback Cylinder (Model PFC) is a linear pneumatic actuator that contains an internal LRT (Linear Resistive Transducer). The PFC can be used for measuring and gauging, positioning, and "on-the-fly" applications. Combine the PFC with the Bimba Pneumatic Control System Model PCS, Digital Panel Meter Model DPM, or the Electronic Controller described below to maximize performance.

The PneuTurn rotary actuator with position feedback (Model PTF) is a rotary rack and pinion actuator that has a rotary potentiometric feedback transducer attached to the output shaft. The PTF can be combined with Bimba's Pneumatic Control System Model PCS described below for closed loop rotary positioning.

The Pneumatic Control System (PCS) is a closed loop pneumatic motion control system that controls the position of the PFC rod or the PTF shaft. The system includes the control electronics and valves necessary to accurately control any Bimba position feedback actuator.

The Digital Panel Meter (Model DPM) is a digital panel meter that has a 16 bit A/D converter and built in microprocessor. When combined with the PFC, the repeatability is 0.001 inch per inch of stroke. The DPM is great for accurate measuring and gauging applications. It is easily calibrated to indicate actual displacement and includes multiple programmable set point outputs. Recommended applications include Go/No Go in-process quality control verification, part identification, and dimensional verification.

The Electronic Controllers can be used for applications that require accuracy larger than ± 0.030 ". It has 10 VDC transducer excitation and fast responding scaleable analog output capability. It is good for applications that use controllers that do not have the required PFC input impedance of 1 Mohm.

Bimba Position Control System Products

Flow Controls

FCP

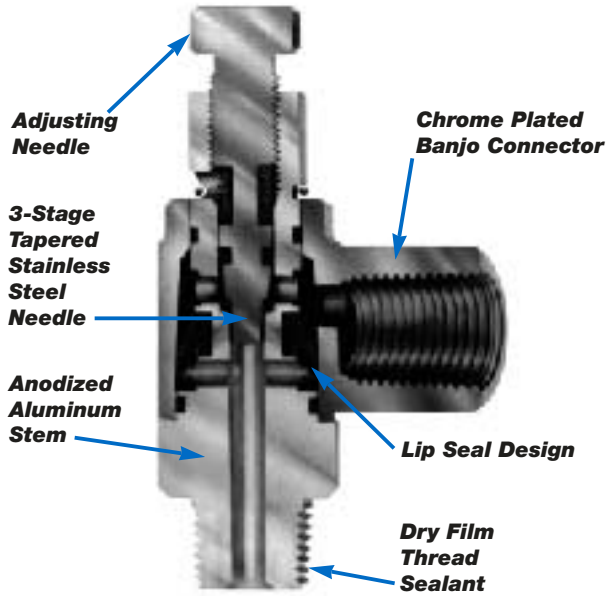

FQP

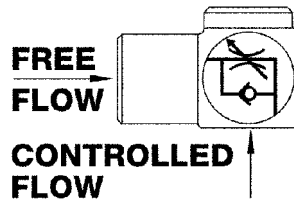
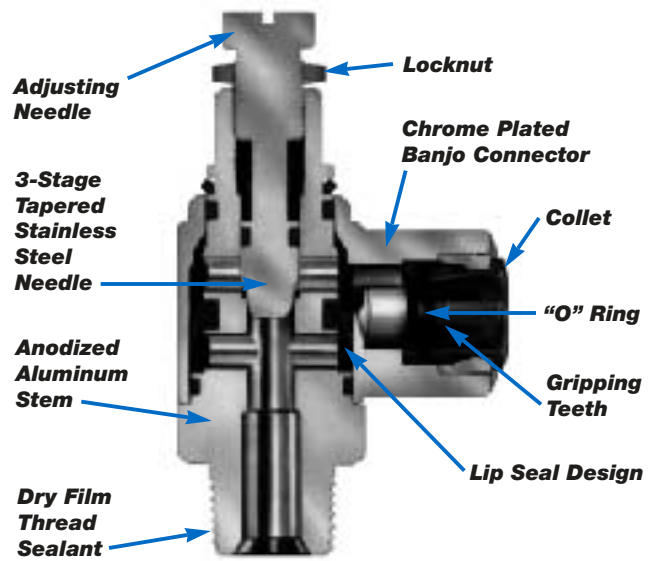

FQPS Series

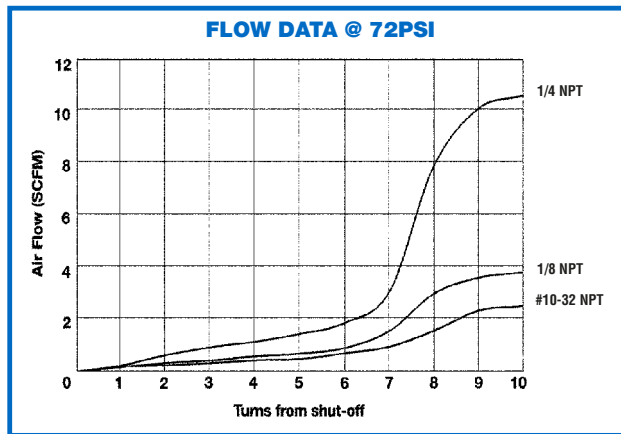

FQP & FCP Series

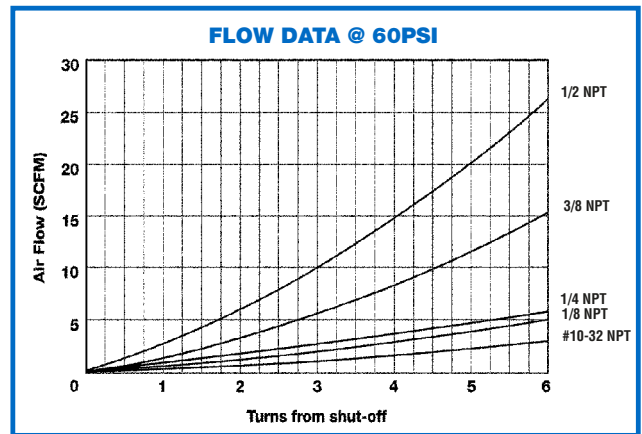

Flow Controls

For 1/8 port,
1/4" OD tubing

FQPS2
\$12.40

FQPS2K
\$12.40

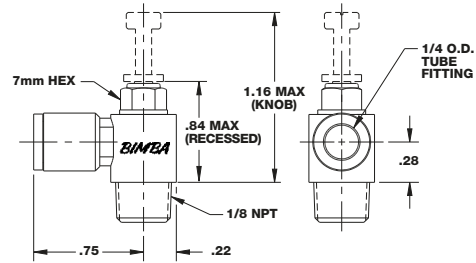

For 1/8 port,
5/32" OD tubing

FQPS21
\$11.35

FQPS21K
\$11.35

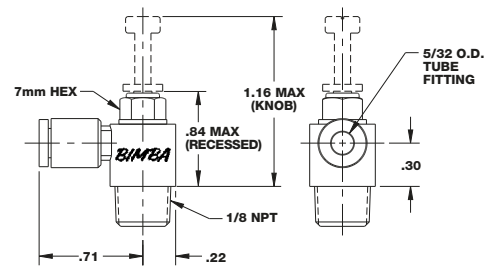

For 1/4 port,
1/4" OD tubing

FQPS44
\$16.00

FQPS44K
\$16.00

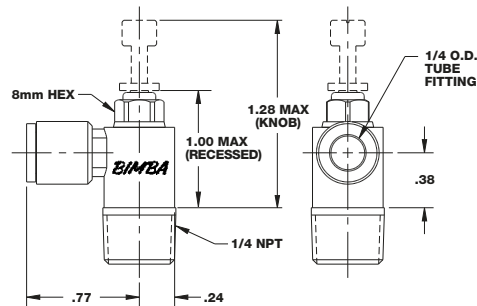

Materials:

Adjusting knob and thread:
Nickel-plated brass

Body:
Glass-filled nylon

Tubing:
Nylon, polyurethane and polyethylene tubing

Maximum Operating Pressure:

135 PSI Air Only

Operating Temperature Range:

30 degrees to 160 degrees F (0°C to 70°C)

Flow Controls

Alignment Couplers

Position Feedback
Cylinder

Position Feedback
PneumTurn

Pneumatic Control
System

Digital Panel Meter

Electronic Controller

Bimba Position Control System Products

Flow Controls

FCP2
\$11.25

FCP2K
\$12.35

FCP2L
\$12.60

For 1/8 port

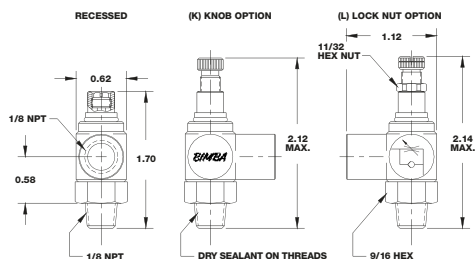

FCP4
\$14.40

FCP4K
\$16.10

FCP4L
\$16.35

For 1/4 port

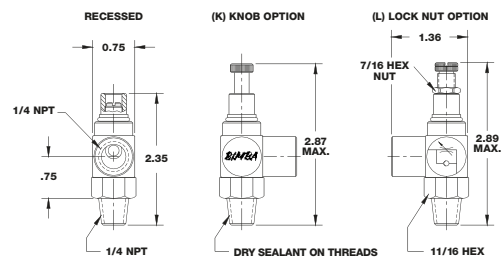

FCP6
\$17.95

FCP6K
\$19.70

FCP6L
\$19.90

For 3/8 port

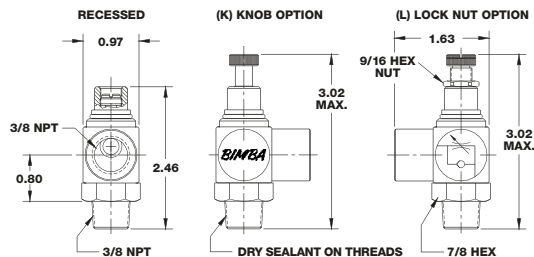

Materials:

Banjo Connector:
Chrome plated,
zinc die cast

Banjo Retaining Ring:
Zinc plated steel

Stem:
High strength anodized
aluminum alloy

Adjusting Needle:
Stainless steel

**“O” Rings and
Lip Seal:**
Buna N

Maximum Operating Pressure:
150 PSI Air Only

Operating Temperature Range:
-20 degrees to +200 degrees F (-25°C to +95°C)

Flow Controls

For 1/8 port,
1/4" OD tubing

FQP2
\$12.40

FQP2K
\$14.25

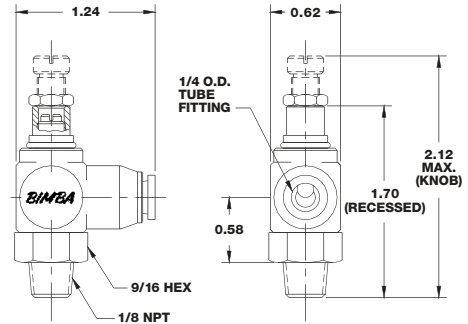

For 1/8 port,
5/32" OD tubing

FQP21
\$12.40

FQP21K
\$14.25

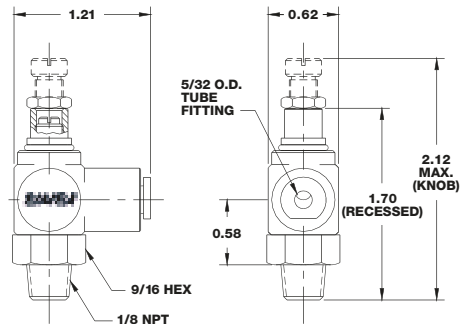

For 1/4 port,
3/8" OD tubing

FQP4
\$15.90

FQP4K
\$18.20

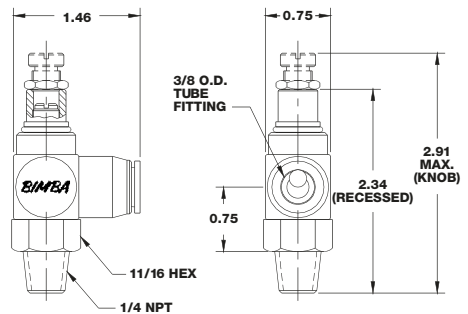

Materials:

Banjo Connector:
Chrome plated,
zinc die cast

Banjo Retaining Ring:
Zinc plated steel

Stem:
High strength anodized
aluminum alloy

Adjusting Needle:
Stainless steel

**"O" Rings and
Lip Seal:**
Buna N

Collet:
Acetal copolymer

Gripping teeth:
Stainless steel

**Collet Retainer
(if applicable):**
Brass

Locknut:
Chrome-plated brass

Tube Types:
All plastic tubing,
including nylon
and polyethylene

Maximum Operating Pressure:
150 PSI Air Only

Operating Temperature Range:
14 degrees to +167 degrees F (-25° to +75°C)

Flow Controls

Alignment Couplers

Position Feedback
Cylinder

Position Feedback
PneuTurn

Pneumatic Control
System

Digital Panel Meter

Electronic Controller

Bimba Position Control System Products

Flow Controls

FQP44
\$15.90

FQP44K
\$18.20

*For 1/4 port,
1/4" OD tubing*

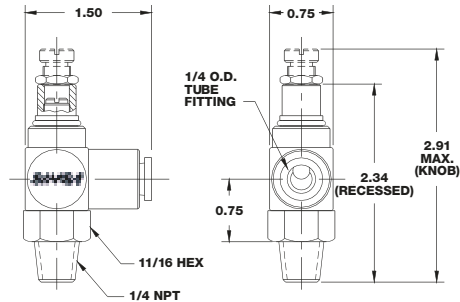

FQP6
\$19.70

FQP6K
\$22.40

*For 3/8 port,
3/8" OD tubing*

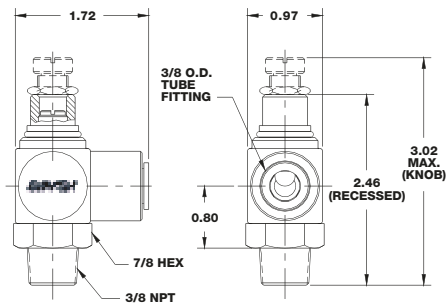

(Units shown in inch for all drawings)

Bimba Needle Valves

Bimba offers a range of Quik-Flo® Needle Valves, allowing for controlled flow of both the air intake and exhaust through the same valve. A needle valve can control a double acting cylinder's extension and retraction by controlling the volume of air entering the cylinder and the volume of air leaving the cylinder.

For additional dimensional information, reference Quik-Flo® Flow Controls on pages 7 and 8. For example, reference FQP1 for QNV1 dimensions.

| Model | Price | Tube Size | Port Size | Cv |
|--------|---------|-----------|-----------|-----|
| QNV2 | \$12.30 | 1/4" | 1/8" NPT | .21 |
| QNV2K | 14.15 | 1/4" | 1/8" NPT | .21 |
| QNV44 | 15.70 | 1/4" | 1/4" NPT | .44 |
| QNV44K | 18.00 | 1/4" | 1/4" NPT | .44 |
| QNV6 | 19.50 | 3/8" | 3/8" NPT | .73 |
| QNV6K | 22.15 | 3/8" | 3/8" NPT | .73 |

All prices are F.O.B. Monee, Illinois and are subject to change without notice.

Alignment Couplers

Standard Coupler – AC250-AC625 / Models 3/8"-24 through 5/8"-18

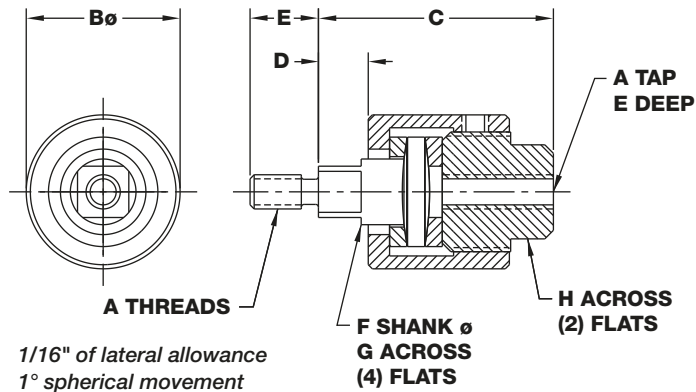

| Part Number* | A | B | C | Hex | D | E | F | G | H | H Hex | Maximum Pull at Yield (lbs.) | List Prices | |
|--------------|----------|--------|--------|---------|-------|------|------|------|--------|--------|------------------------------|-------------|---------|
| | | | | | | | | | | | | AC | ACH |
| AC375 | 3/8"-24 | 1-1/8" | 1-3/4" | 2" | 3/8" | 1/2" | 1/2" | 3/8" | 11/16" | 1-1/8" | 8,300 | \$27.00 | \$54.15 |
| AC437 | 7/16"-20 | 1-1/4" | 2" | 2-5/32" | 7/16" | 3/4" | 5/8" | 1/2" | 13/16" | 1-1/8" | 10,000 | 34.75 | 58.45 |
| AC500 | 1/2"-20 | 1-1/4" | 2" | 2-5/32" | 7/16" | 3/4" | 5/8" | 1/2" | 13/16" | 1-1/8" | 14,000 | 34.75 | 58.45 |
| AC625 | 5/8"-18 | 1-1/4" | 2" | 2-5/32" | 7/16" | 3/4" | 5/8" | 1/2" | 13/16" | 1-1/4" | 19,000 | 37.00 | 58.45 |

*Please specify AC or ACH coupler when ordering AC-750 (Standard Coupler) ACH-750 (Hex Coupler)
Jam nut sold separately for 1/4"-28 through 1"-14 size.
All prices are F.O.B. Monee, Illinois and are subject to change without notice.

Features and Advantages

- Bimba's new miniature coupler design allows excellent freedom of movement on the three new, miniature sizes; #5-40 through #10-32 sizes.
- The miniature couplers allow up to 20 degrees of spherical movement and 0.02" lateral allowance with only .002" of axial play and are manufactured from high tensile, hardened and blackened steel components.
- Larger sizes are available, from 1/4"-28 to 1"-14, with 1 degree of spherical movement and 1/16" of lateral allowance.
- The alignment allowances can eliminate the need for expensive precision machining in rigidly mounted applications.
- Alignment couplers help reduce binding and simplify field alignment problems, enhancing cylinder performance and reducing seal and bearing wear.
- An innovative design to resist vibrational loosening is available on sizes 5/16"-24 and larger. In the ACH style coupler, a slot is milled through the tapped mounting threads. Two socket head cap screws are strategically placed to allow the coupler to be clamped to the rod, offering a superior strength connection.

Jam Nuts

| Size | Part Number | Price |
|----------|-------------|-------|
| 3/8"-24 | D-801 | \$.25 |
| 7/16"-20 | D-154 | .25 |
| 1/2"-20 | D-98 | .35 |
| 5/8"-18 | D-9 | .35 |

Bimba Position Control System Products

The Bimba Position Feedback Cylinder provides continuous position sensing in a lightweight, small-bore air cylinder.

Ideal for applications where magnetic position sensing is impractical, where variations in cylinder speed or stroke are needed, or where an operation requires constant monitoring of cylinder position.

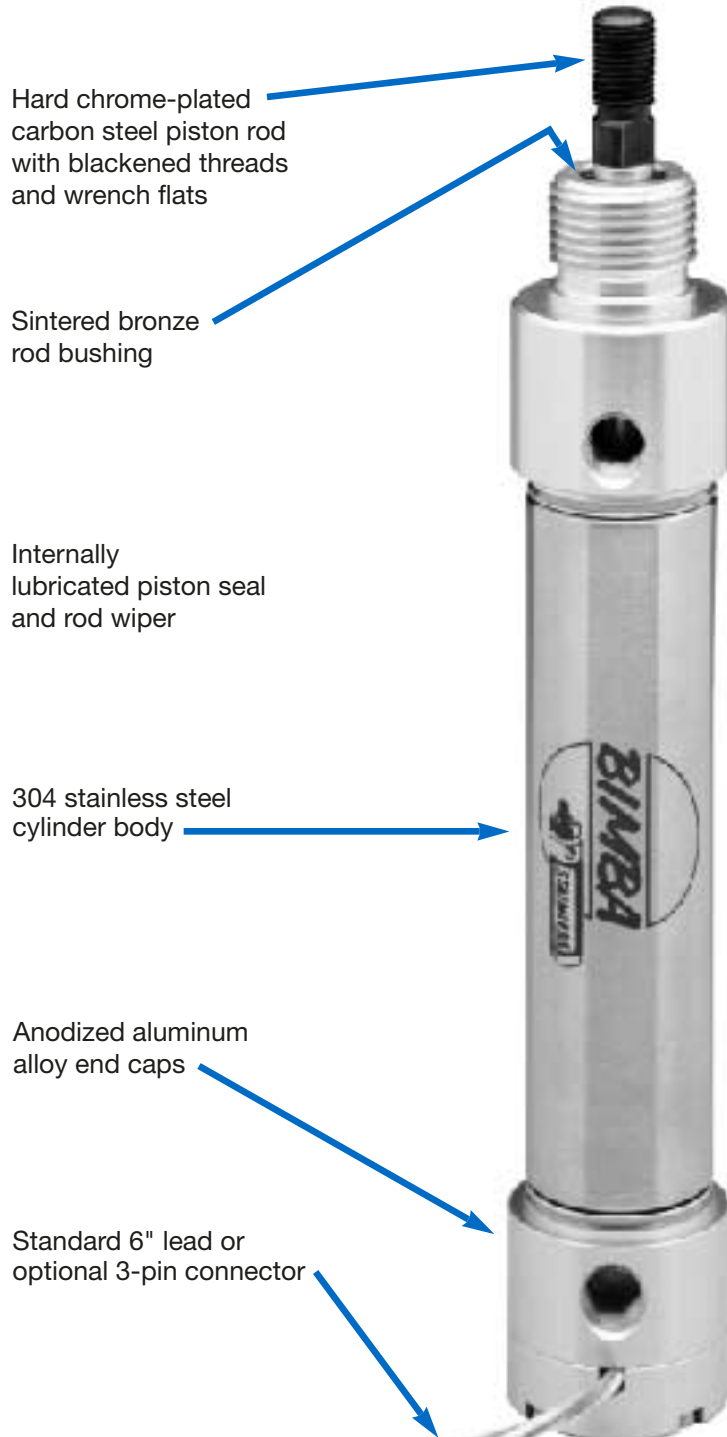

Advantages

- Highly accurate: infinite resolution, linearity of ± 1 percent of full stroke, ± 0.001 " mechanical repeatability.
- Less than 0.75" longer than conventional magnetic piston cylinders.
- Reduces weight and size.
- Repairable.
- Internally-lubricated seals.
- Standard wipers and piston bearing strips for long cylinder life.
- Optional bumpers.
- Choice of standard 6" lead wire or 3-pin connector.
- Electronic controllers available for dual set point and scalable analog output applications.
- Rear head cap can be rotated for optimal positioning of lead or connector.

How it Works

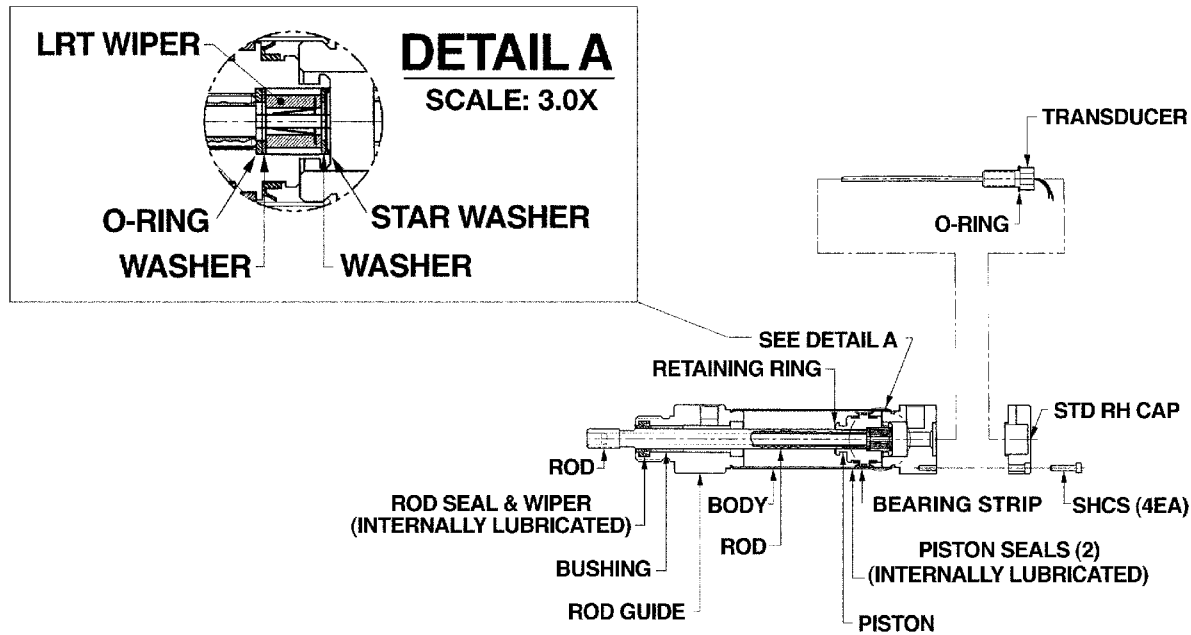

The *Bimba Position Feedback Cylinder* contains a Linear Resistive Transducer (LRT) or potentiometer mounted in the cylinder rear head. The LRT probe, which has a resistive element on one side and a collector strip on the other, is inside the cylinder rod. A wiper assembly is installed in the piston. As the piston moves, an electrical circuit is created between the resistive element and collector strip. The resulting voltage is directed externally via wiring. The output voltage is proportional to the wiper position on the resistive element, which allows the cylinder position to be determined.

For example, in a 12-inch stroke cylinder, the output voltage would be 0 VDC when fully retracted and 10 VDC when fully extended. Voltage readings of 2.5 and 5.833 VDC would indicate cylinder extensions of 3 inches and 7 inches.

The accuracy of an LRT is determined by three factors: resolution, linearity and repeatability.

Resolution refers to the smallest change that can be detected on the LRT. The Bimba LRT has infinite resolution, and can be divided into as many parts as the electronics allow. For example, with a 12-bit, 4096-part controller, the stroke could be divided into 4096 parts. When 10 VDC are placed on a 10" cylinder, the smallest detectable increment would be $10 \text{ VDC} \div 4096 = 2.4 \text{ millivolts}$ or 0.0024". Resolution is stroke sensitive, i.e., the longer the stroke, the less resolution.

Linearity refers to the maximum deviation of the output voltage to a straight line. The Bimba LRT's linearity is ± 1 percent of stroke.

Repeatability is the ability of the LRT to provide the same output voltage relative to a unique cylinder position each time the cylinder is cycled. Mechanical repeatability of the Bimba Position Feedback Cylinder is ± 0.001 ".

Flow Controls

Alignment Couplers

Position Feedback Cylinder

Position Feedback PneumTurn

Pneumatic Control System

Digital Panel Meter

Electronic Controller

How to Order

The model number of all Position Feedback Cylinders consists of three alphanumeric clusters. These designate product type, bore size and stroke length, and mounting style and options. Please refer to the charts

below for an example of model number **PFC-0912-BFP**. This is an 1-1/16" bore, 12" stroke Position Feedback Cylinder with block front mounting and a plug connector.

PFC-0912-BFP

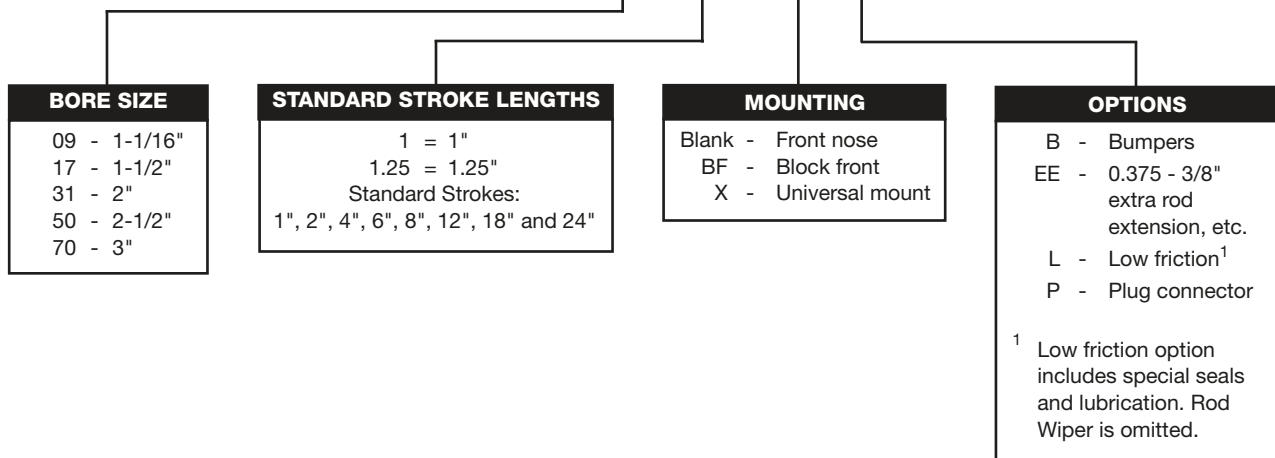

Approximate Power Factors

| | |
|---------|-------|
| 1-1/16" | = 0.9 |
| 1-1/2" | = 1.7 |
| 2" | = 3.1 |
| 2-1/2" | = 5.0 |
| 3" | = 7.0 |

For example, a PFC-0912-BFP will exert a force of 0.9 times the air line pressure; a PFC-506-XB will exert a force of 5.0 times the air line pressure, etc.

Bimba Position Control System Products

List Prices

| Bore | Base | Stroke Adder (per inch) | Mounting | | Options | | | |
|--------------|----------|-------------------------|-----------------|-------------|-------------------------------|-----------|-----------------|---------------------|
| | | | B F Block Front | X Universal | EE Extra Extension (per inch) | B Bumpers | L* Low Friction | P** Plug Connectors |
| 1-1/16" (09) | \$234.80 | \$12.50 | \$14.70 | \$4.00 | \$3.60 | \$2.20 | \$10.80 | \$34.10 |
| 1-1/2" (17) | 246.00 | 15.00 | 15.90 | 4.70 | 4.40 | 5.65 | 10.80 | 34.10 |
| 2" (31) | 265.80 | 17.40 | 19.30 | 5.90 | 5.70 | 7.60 | 10.80 | 34.10 |
| 2-1/2" (50) | 285.70 | 19.90 | 23.30 | 7.50 | 7.20 | 9.75 | 10.80 | 34.10 |
| 3" (70) | 306.80 | 22.40 | 29.90 | 10.00 | 10.80 | 9.75 | 10.80 | 34.10 |

* Specify Option L for motion Control Applications with the PCS Control System.

Accessories

| Bore | Mounting Nut | Mounting Bracket | Rod Clevis | Pivot Bracket |
|--------------|--------------|------------------|------------|---------------|
| 1-1/16" (09) | D-2545 | D-8316 | D-8310-A | D-8322-A |
| 1-1/2" (17) | D-8484 | D-8318 | D-8311-A | D-8324-A |
| 2" (31) | D-508 | D-8319 | D-8313-A | D-8325-A |
| 2-1/2" (50) | D-2540 | D-8320 | D-8314-A | D-8326-A |
| 3" (70) | D-5379 | D-19127 | D-8314-A | D-8326-A |

See Bimba Catalog OL for Accessory Prices.

Control Units

| Model | Price |
|---------------|----------|
| 120AC4-20mA | \$210.00 |
| 120AC1-10DC | 210.00 |
| 12/24DC4-20mA | 240.00 |
| 12/24DC1-10DC | 240.00 |
| DPM | 410.00 |
| DPMA | 495.00 |
| DPMS | 480.00 |
| DPM-485 | 70.00 |
| DPM-232 | 70.00 |
| DPM-DNET | 170.00 |
| DPM-A | 110.00 |
| DPM-R | 70.00 |

**Cables (required for plug connector - P option)

| Model | Price |
|-------|---------|
| C4-S | \$23.00 |
| C4X-S | 33.00 |
| C5 | 23.00 |
| C5X | 33.00 |

All prices are F.O.B. Monee, Illinois and are subject to change without notice.

Bimba Position Control System Products

Nose Mount

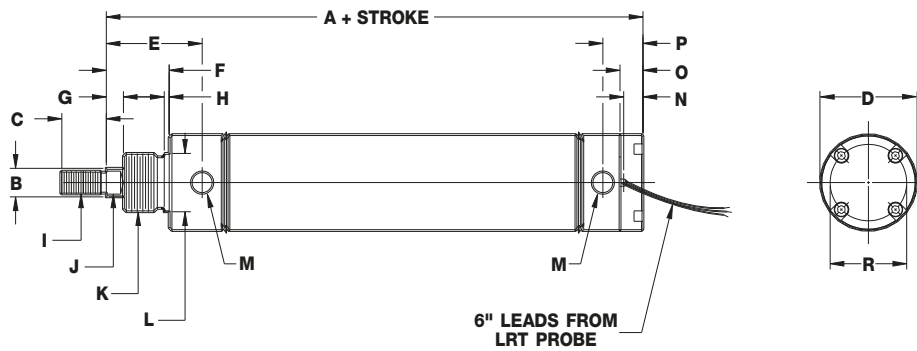

Universal Mount (for stud or pivot). Includes bushing.

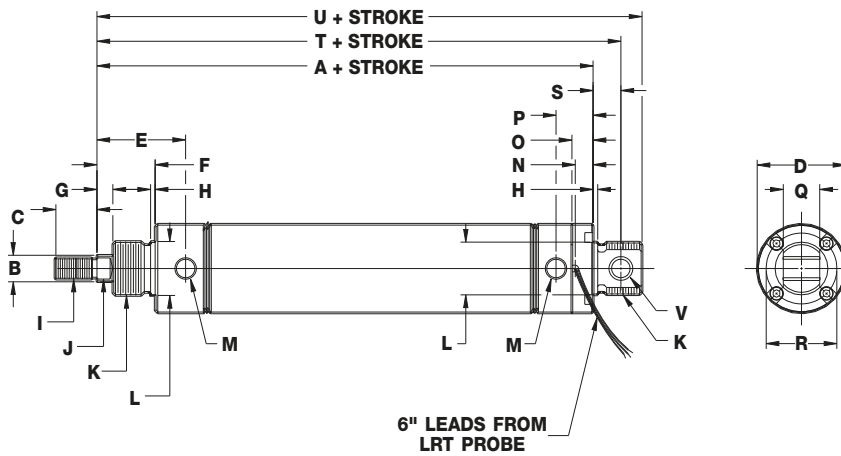

Block Mount

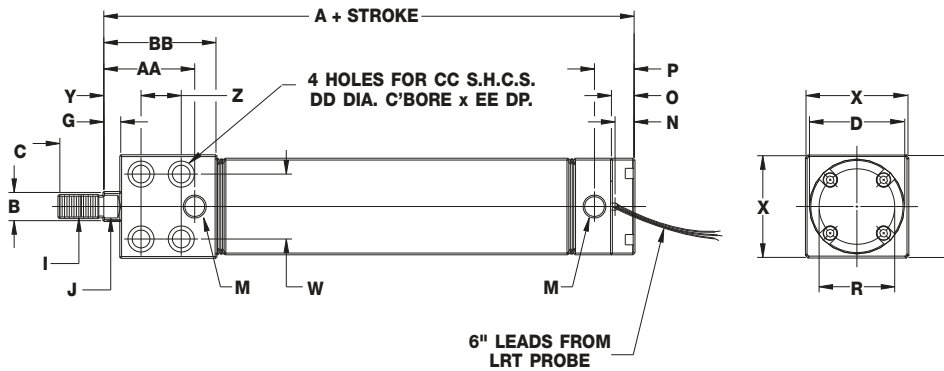

Note: Mounting holes farthest from rod end are omitted for -L option for 11/16" bore.

Dimensions

| | 1-1/16" Bore (09) | 1-1/2" Bore (17) | 2" Bore (31) | 2-1/2" Bore (50) | 3" Bore (70) |
|-----------|----------------------|---------------------|-----------------|---------------------|-----------------|
| A | 4.59 | 4.88 | 5.72 | 6.41 | 6.78 |
| B | Ø 0.38 | Ø 0.50 | Ø 0.63 | Ø 0.75 | Ø 0.75 |
| C | 0.63 | 0.88 | 1.00 | 1.25 | 1.25 |
| D | Ø 1.31 | Ø 1.58 | Ø 2.09 | Ø 2.58 | Ø 3.13 |
| E | 1.75 | Option L 1.52 | 1.72 | 2.10 | 2.28 |
| F | 1.06 | 1.13 | 1.38 | 1.50 | 1.69 |
| G | 0.31 | 0.31 | 0.38 | 0.44 | 0.44 |
| H | 0.08 | 0.09 | 0.11 | 0.13 | 0.13 |
| I | 3/8-24 UNF | 7/16-20 UNF | 1/2-20 UNF | 5/8-18 UNF | 5/8-18 UNF |
| J | 0.31 | 0.44 | 0.50 | 0.63 | 0.63 |
| K | 7/8-14 UNF | 1-1/8-12 UNF | 1-1/4-12 UNF | 1-3/8-12 UNF | 1-1/2-12 UNF |
| L | Ø 0.87 | Ø 1.12 | Ø 1.25 | Ø 1.37 | Ø 1.62 |
| M | 1/8 NPT | 1/4 NPT | 1/4 NPT | 3/8 NPT | 3/8 NPT |
| N | 0.36 | 0.36 | 0.42 | 0.48 | 0.55 |
| O | 0.44 | 0.44 | 0.50 | 0.56 | 0.63 |
| P | 0.84 | 0.81 | 0.88 | 1.12 | 1.88 |
| Q | 0.62 | 0.74 | 0.86 | 0.99 | 0.99 |
| R | Ø 1.09 | Ø 1.36 | Ø 1.67 | Ø 2.06 | Ø 2.44 |
| S | 0.47 | 0.56 | 0.66 | 0.75 | 0.81 |
| T | 5.06 | 5.44 | 6.38 | 7.16 | 7.60 |
| U | 5.44 | 5.91 | 6.88 | 7.78 | 8.22 |
| V | Ø 0.31 | Ø 0.38 | Ø 0.44 | Ø 0.50 | Ø 0.50 |
| W | 0.88 | 1.25 | 1.44 | 1.88 | 2.25 |
| X | 1.38 | 1.75 | 2.25 | 2.75 | 3.25 |
| Y | 0.75 | 0.69 | 0.75 | 0.88 | 0.94 |
| Z | 0.88 | 0.75 | 1.00 | 1.25 | 1.38 |
| AA | 1.63 | Option L 1.52 | 1.68 | 1.75 | 2.13 |
| BB | 2.03 | 2.00 | 2.41 | 2.72 | 2.91 |
| CC | #10 | 1/4 | 3/8 | 7/16 | 1/2 |
| DD | Ø 0.33 | Ø 0.41 | Ø 0.58 | Ø 0.67 | Ø 0.77 |
| EE | 0.20 | 0.25 | 0.39 | 0.45 | 0.52 |

Bumper Length Adder: 0.25"

Flow Controls

Alignment Couplers

Position Feedback
Cylinder

Position Feedback
PneuTurn

Pneumatic Control
System

Digital Panel Meter

Electronic Controller

Options

3-pin Connector

Wire Colors

| WIRES | 6" LEADS | PLUG |
|--------|----------|-------|
| Input | Red | Blue |
| Ground | Black | Black |
| Output | White | Brown |

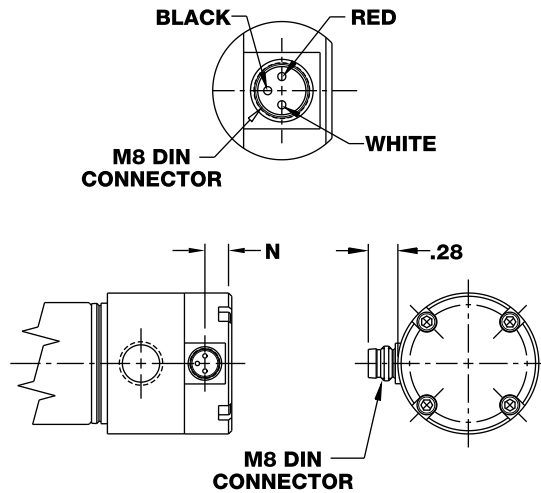

Straight-Models C4-S (2m), C4X-S (5m).

Right Angle-Models C5 (2m), C5X (5m)

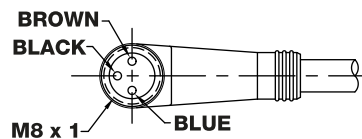
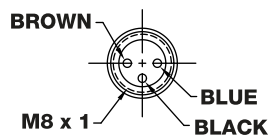
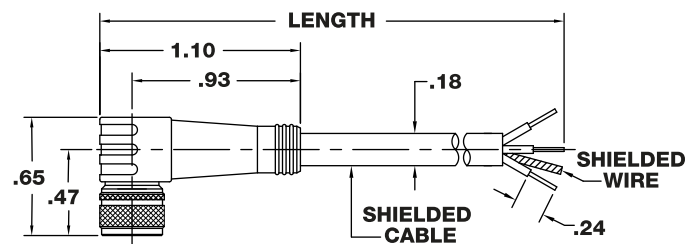
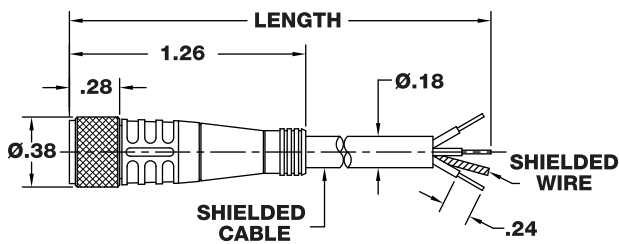

Cable: 24 AWG PVC insulated, fine stranded copper conductors, with Gray PVC jacket

Accessories

Mounting Nuts



Model D-2540

**Models D-2545
D-8484
D-508
D-5379**

| Bore | Model | A | B | C | D | E |
|--------------|--------|------|------|-----------------|------|------|
| 1-1/16" (09) | D-2545 | 1.31 | 0.48 | 7/8-14 UNF-2B | N/A | N/A |
| 1-1/2" (17) | D-8484 | 1.69 | 0.61 | 1-1/8-12 UNF-2B | N/A | N/A |
| 2" (31) | D-508 | 1.88 | 0.50 | 1-1/4-12 UNF-2B | 1.81 | 0.03 |
| 2-1/2" (50) | D-2540 | 1.88 | 0.50 | 1-3/8-12 UNF-2B | 1.81 | 0.03 |
| 3" (70) | D-5379 | 2.25 | 0.50 | 1-1/2-12 UNF-2B | 2.25 | 0.02 |

Mounting Bracket

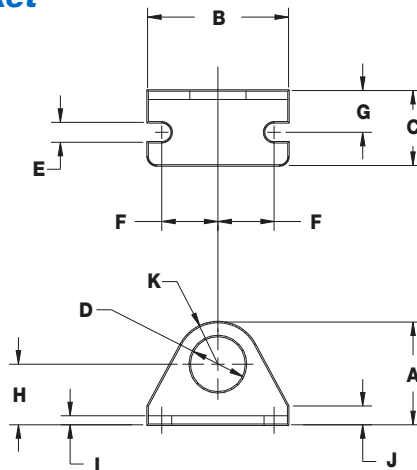

| Bore | Model | A | B | C | D | E | F | G | H | I | J |
|--------------|---------|------|------|------|-------|------|------|------|------|------|------|
| 1-1/16" (09) | D-8316 | 1.75 | 2.12 | 1.16 | 0.875 | 0.28 | 0.78 | 0.66 | 1.00 | 0.16 | 0.32 |
| 1-1/2" (17) | D-8318 | 2.19 | 2.75 | 1.44 | 1.125 | 0.34 | 1.06 | 0.81 | 1.25 | 0.19 | 0.38 |
| 2" (31) | D-8319 | 2.44 | 3.00 | 1.59 | 1.25 | 0.34 | 1.19 | 0.91 | 1.38 | 0.22 | 0.44 |
| 2-1/2" (50) | D-8320 | 2.81 | 3.75 | 1.88 | 1.312 | 0.41 | 1.50 | 1.06 | 1.62 | 0.25 | 0.50 |
| 3" (70) | D-19127 | 3.14 | 4.38 | 1.62 | 1.625 | 0.34 | 1.75 | 1.00 | 1.89 | 0.25 | 0.89 |

Flow Controls

Alignment Couplers

Position Feedback
Cylinder

Position Feedback
PneuTurn

Pneumatic Control
System

Digital Panel Meter

Electronic Controller

Accessories

Rod Clevis

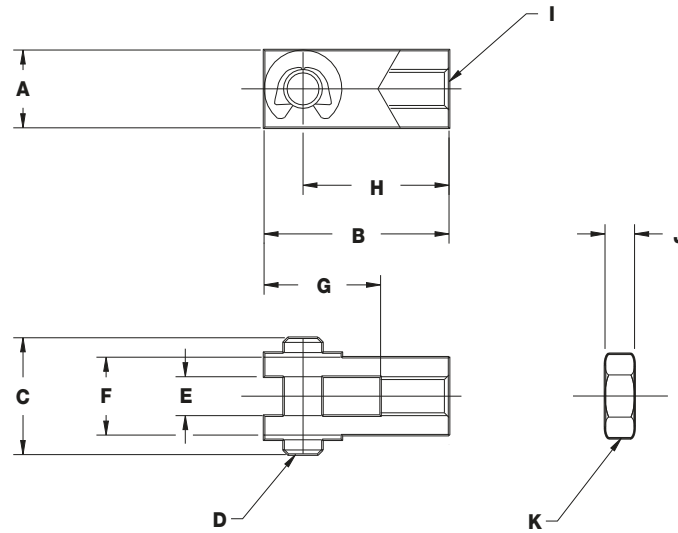

| Bore | Model | A | B | C | D | E | F | G | H | I | J | K |
|--------------------------|----------|------|------|------|-------|------|------|------|------|-------------|------|-----------------|
| 1-1/16" (09) | D-8310-A | 0.62 | 1.69 | 0.88 | 0.312 | 0.31 | 0.62 | 0.94 | 1.38 | 3/8-24 THD | 0.22 | 3/8-24 HEX NUT |
| 1-1/2" (17) | D-8311-A | 0.75 | 2.00 | 1.03 | 0.375 | 0.38 | 0.75 | 1.12 | 1.62 | 7/16-20 THD | 0.25 | 7/16-20 HEX NUT |
| 2" (31) | D-8313-A | 0.88 | 2.31 | 1.14 | 0.438 | 0.44 | 0.88 | 1.31 | 1.88 | 1/2-20 THD | 0.31 | 1/2-20 HEX NUT |
| 2-1/2" (50) & 3" (70) | D-8314-A | 1.00 | 2.75 | 1.38 | 0.50 | 0.50 | 1.00 | 1.50 | 2.25 | 5/8-18 THD | 0.38 | 5/8-18 HEX NUT |

Pivot Bracket

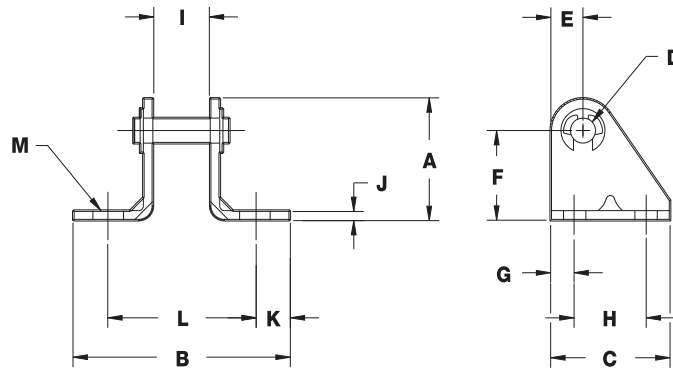

| Bore | Model | A | B | C | D | E | F | G | H | I | J | K | L | M |
|--------------------------|----------|------|------|------|-------|------|------|------|------|------|------|------|------|------|
| 1-1/16" (09) | D-8322-A | 1.31 | 2.38 | 1.31 | 0.312 | 0.31 | 1.00 | 0.25 | 0.81 | 0.62 | 0.16 | 0.31 | 1.75 | 0.28 |
| 1-1/2" (17) | D-8324-A | 1.62 | 3.00 | 1.62 | 0.375 | 0.38 | 1.25 | 0.31 | 1.00 | 0.75 | 0.19 | 0.44 | 2.13 | 0.34 |
| 2" (31) | D-8325-A | 1.81 | 3.25 | 1.81 | 0.438 | 0.44 | 1.38 | 0.31 | 1.19 | 0.88 | 0.25 | 0.44 | 2.38 | 0.34 |
| 2-1/2" (50) & 3" (70) | D-8326-A | 2.12 | 4.00 | 2.12 | 0.50 | 0.50 | 1.62 | 0.38 | 1.38 | 1.00 | 0.25 | 0.62 | 2.75 | 0.41 |

Engineering Specifications

| | |
|---------------------------|---|
| Repeatability: | ±0.001" Cylinder Only. <i>Refer to specifications in the following sections for positioning or measuring repeatability. Power supply ripple and A/D error may reduce repeatability when PFC is utilized with industrial control systems.</i> |
| Nonlinearity: | ± 1 percent of full stroke |
| Resolution: | Infinite |
| Signal Input: | 10 VDC typical |
| Input Impedance Required: | 1 MOhm |
| Signal Output: | > 0 to slightly less than FS signal input <i>(The internal electrical stroke is slightly larger than the mechanical stroke of cylinder)</i> |
| Maximum speed: | 25 in./sec. |
| Rated Life of Cylinder: | 1,800 miles of travel |
| Rated Life of Probe: | 1000 linear miles or 10 million cycles |
| Pressure Rating: | 150 psi |
| Temperature Rating: | 0° to 200°F* |
| Interface: | 6" standard leads or optional 8mm DIN connector |
| Cylinder Body: | 304 stainless steel |
| Piston Rod: | Hard chrome plated carbon steel with blackened threads and wrench flats |
| Rod Bushing: | Sintered bronze |
| End Caps: | Anodized Aluminum alloy |
| Piston Seal: | Internally lubricated urethane (standard) Internally lubricated Buna (L option) |
| Rod Wiper: | Internally lubricated Buna N (omitted on L option) |
| Rod Seal: | Internally lubricated Buna N (N/A on standard model) |

*Special low temperature lubrication is required for positioning applications using option L seals below 35°F.

| ESTIMATED CYLINDER WEIGHTS (LBS) | | | | | |
|----------------------------------|---------|--------|------|--------|------|
| | 1-1/16" | 1-1/2" | 2 | 2-1/2" | 3 |
| PFC- | 0.44 | 0.88 | 2.02 | 2.78 | 3.62 |
| PFC-X | 0.49 | 0.96 | 2.14 | 2.96 | 3.85 |
| PFC-BF | 0.54 | 1.07 | 2.28 | 3.02 | 4.08 |
| ADDER WT/IN | 0.06 | 0.10 | 0.15 | 0.20 | 0.29 |

Repair Parts

| PART | DESCRIPTION |
|---------------------------|----------------------|
| RPFC-Bore Stroke-Options* | Replacement Cylinder |
| RD-53129-Stroke-Options** | Replacement Probe |

* Only options required are BF, B, and L as Rear Cap is not included.

** Only option required for replacement probe is Option P.

How to Order

Add the bore size, stroke and options needed to the basic model number shown above for a replacement cylinder.

Add the stroke length to the basic model number shown above for a replacement probe. For example, a replacement probe for a 6" stroke Position Feedback Cylinder would be ordered as a RD-53129-6.

LRT CIRCUIT DIAGRAM

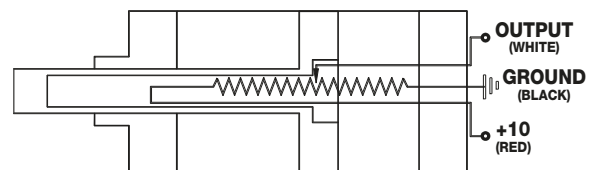

STROKE = 0; OUTPUT VOLTAGE = 0 VOLTS
STROKE = FULL; OUTPUT VOLTAGE = 10 VOL

Flow Controls

Alignment Couplers

Position Feedback Cylinder

Position Feedback PneumTurn

Pneumatic Control System

Digital Panel Meter

Electronic Controller

How It Works

Bimba Pneumatic Control System Model PCS



The Bimba Pneumatic Control System (Model PCS) is designed to control any pneumatic Bimba position feedback actuator. This includes the Position Feedback Cylinder (PFC) for linear motion and the Position Feedback Pneu-Turn (PTF) for rotary motion. The system is a closed-loop electronic controller with pneumatic valves that can accurately position the actuator rod or shaft and hold it in position with a high degree of accuracy and force. The system accomplishes the long term goal of using pneumatic technology to accurately stop and hold the rod or shaft at any desired position.

The standard PCS accepts a 0 to 10 VDC analog command signal. The command signal is used as a reference to move to and hold a specific position. Order Option C if a 0 to 20 mA or a 4 to 20 mA analog command signal is required. For example, if the application has a stroke of 10 inches (i.e., the electrical zero and span is set for a 10 inch stroke), then a 1 volt change in the command voltage is equal to a 1 inch movement. Similarly, a change in command signal of 0.005 of a volt equals a position change of 0.005 of an inch for the same 10 inch stroke application. If the application has a stroke of 5 inches, a change of 1 volt in the command signal represents a 1/2" inch movement. For rotary applications, the convention is similar. If the application has a rotation of 180 degrees, then a 1 volt change in the command signal is equal to 18 degrees of rotation.

The system utilizes the feedback from the actuator to close the control loop. The control loop compares the system's command signal (the 0-10 VDC, 0-20mA, or 4-20mA input command signal) to the feedback signal from the actuator. The difference between the command and feedback is referred to as the error term. When the error term is zero, all valves close, trapping air on both sides of the actuator piston. (The error term is considered to be zero when it is within the deadband range. The deadband range is an adjustable range that determines the final repeatability of the system. The Application Sizing chart located later in this section shows recommended deadband ranges for given application parameters.) This holds the rod or shaft at its commanded position. If some force or weight attempts to move the rod or shaft out of the commanded position, the system will react by increasing the restoring force eventually to full supply pressure, if necessary. Likewise, if the command signal changes, the system will respond to make the feedback equal the command signal.

There are four adjustments on the PCS system, adjustable via four trim pots. They include the Zero, Span, Decel, and Deadband adjustments. The Zero and Span adjustments allow you to set the zero and full scale position of the actuator to match the input (command) signal. The Decel and Deadband adjustments are used to optimize the performance of the system based on application parameters. These adjustments are described in detail in the Operating Manual, which is included with each system.

The actual accuracy/repeatability of the movements will depend on many factors, including signal noise, load, velocity, supply pressure, supply voltage, and application friction. Refer to the Application Sizing charts found later in this section for detailed information regarding sizing and suggestions for your application.

Bimba Position Control System Products

How to Order

The model number for all Pneumatic Control Systems consist of three alpha numeric clusters. These designate product type, flow size, and options. Please refer to the charts below for an

example of model number PCS-1-Q. This is a system with a Cv of 0.02 and the Quick Connect connector option.

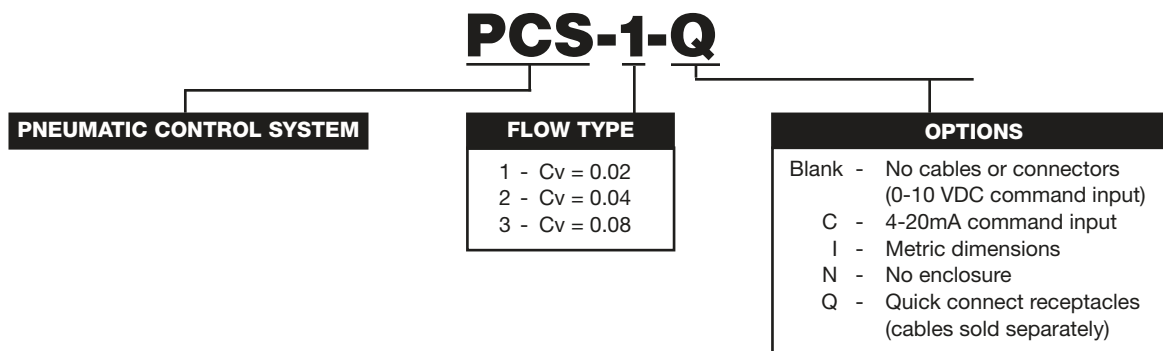

This initial offering covers 1-1/16" (09) through 2" (31) bore size Position Feedback Cylinders. Additional PCS units will be offered shortly that will cover applications requiring bore sizes up to 3" (PFC-70). Refer to the Position Feedback

Cylinder section and the Position Feedback Pneu-Turn section for ordering information regarding either actuator. Ensure that the Position Feedback Cylinder -L option is specified for motion control applications.

List Prices

| Model | Base | Options | | | |
|-------|-----------|---------|-----|---------|----------|
| | | C | I | N | Q |
| PCS-1 | \$1075.00 | \$5.00 | N/C | \$75.00 | \$200.00 |
| PCS-2 | 1075.00 | 5.00 | N/C | 75.00 | 200.00 |
| PCS-3 | 1075.00 | 5.00 | N/C | 75.00 | 200.00 |

Accessories

| Part Number | Description | Price |
|---------------|---|---------|
| PCS-CBL-PWR | 2 meter Power Cable for Quick Connect Option | \$26.00 |
| PCS-CBL-PWR-X | 5 meter Power Cable for Quick Connect Option | 40.00 |
| PCS-CBL-CMD | 2 meter Command Signal Cable for Quick Connect Option | 42.00 |
| PCS-CBL-CMD-X | 5 meter Command Signal Cable for Quick Connect Option | 60.00 |
| PCS-CBL-FBK | 2 meter Feedback Cable for Quick Connect Option | 50.00 |
| PCS-CBL-FBK-X | 5 meter Feedback Cable for Quick Connect Option | 70.00 |

*One power, command and feedback cable required if option Q is purchased.
All prices are F.O.B. Monee, Illinois and are subject to change without notice.*

Dimensions

Shown in inches (millimeters)

Enclosure

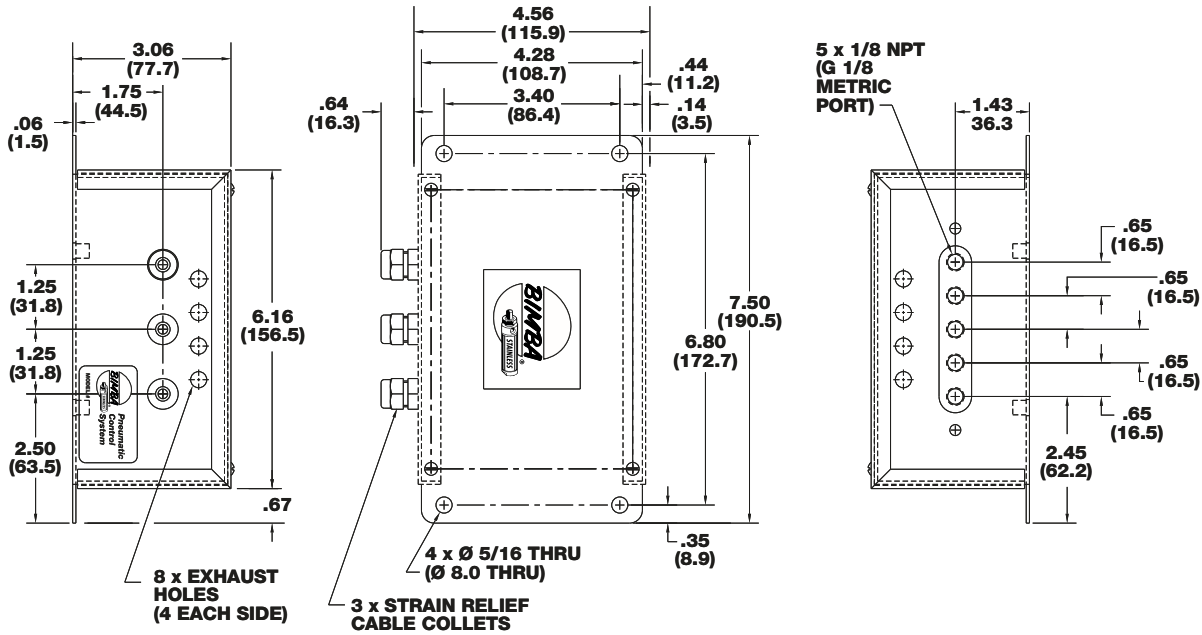

Option Q

(Quick Connect Receptacle)

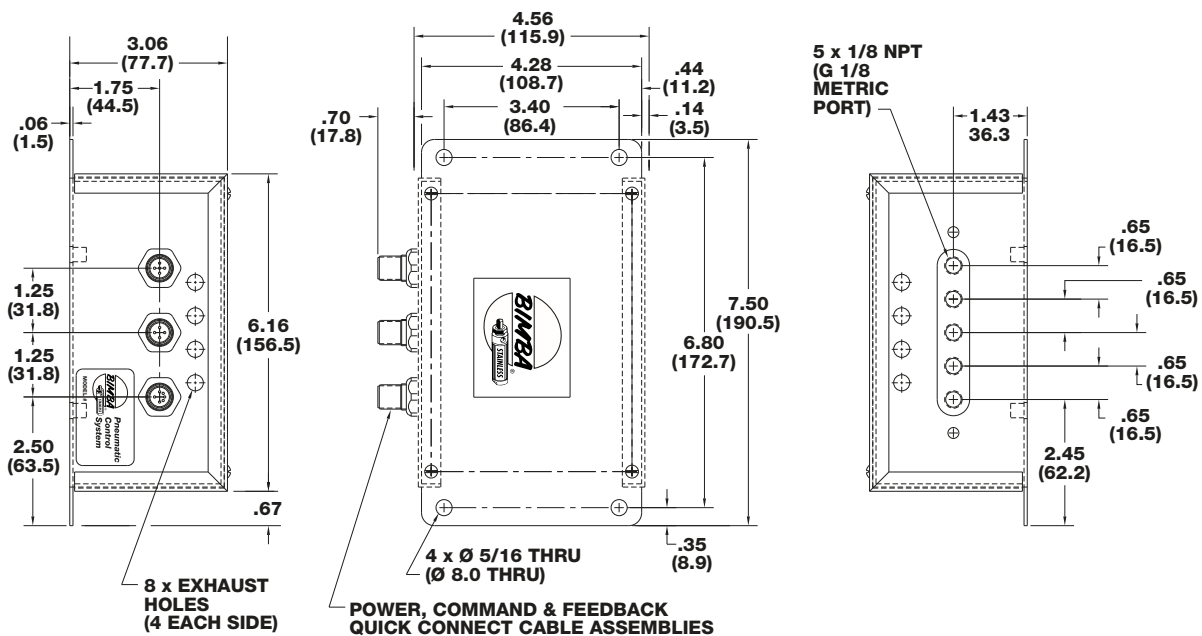

Dimensions

Shown in inches (millimeters)

Quick Connect Cables

PCS-CBL-PWR

SPECIFICATIONS
5 CONDUCTORS OF 22 AWG LEADS RATED
TO 250 V AT 4 AMPS
SHIELDED

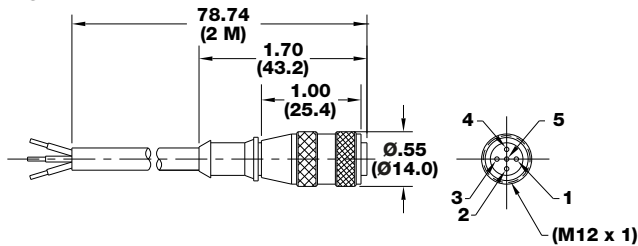

PCS-CBL-PWR-X

SPECIFICATIONS
5 CONDUCTORS OF 22 AWG LEADS RATED
TO 250 V AT 4 AMPS
SHIELDED

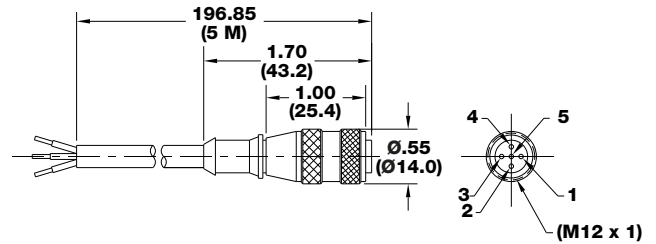

PCS-CBL-PWR Wire Color Codes

| Color | Pin | Description |
|-------|-----|-------------|
| Brown | 1 | Positive |
| White | 2 | N/C |
| Blue | 3 | Negative |
| Black | 4 | N/C |

PCS-CBL-CMD Wire Color Codes

| Color | Pin | Description |
|--------------|-----|------------------|
| Brown | 1 | Input |
| White | 2 | @ Position |
| Blue | 3 | Ground |
| Black | 4 | Current Position |
| Green/Yellow | 5 | N/C |
| Pink | 6 | N/C |

PCS-CBL-CMD

SPECIFICATIONS
6 CONDUCTORS OF 24 AWG LEADS RATED
TO EITHER 30 VAC OR 36 VDC AT 4 AMPS
SHIELDED

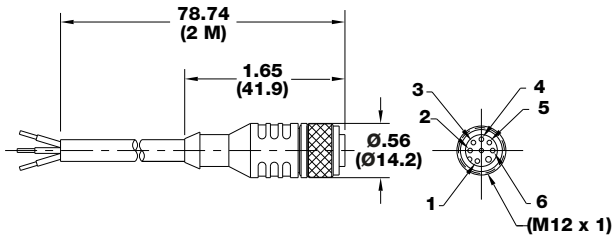

PCS-CBL-CMD-X

SPECIFICATIONS
6 CONDUCTORS OF 24 AWG LEADS RATED
TO EITHER 30 VAC OR 36 VDC AT 4 AMPS
SHIELDED

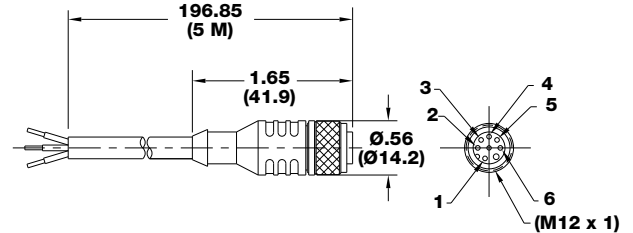

PCS-CBL-FBK

SPECIFICATIONS
3 CONDUCTORS OF 24 AWG LEADS RATED
TO 120 V AT 4 AMPS
SHIELDED

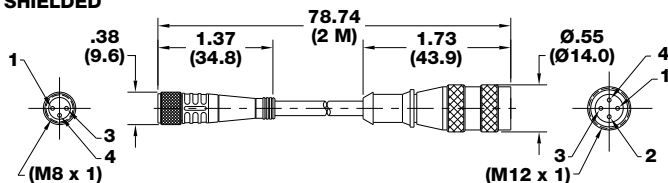

PCS-CBL-FBK-X

SPECIFICATIONS
3 CONDUCTORS OF 24 AWG LEADS RATED
TO 120 V AT 4 AMPS
SHIELDED

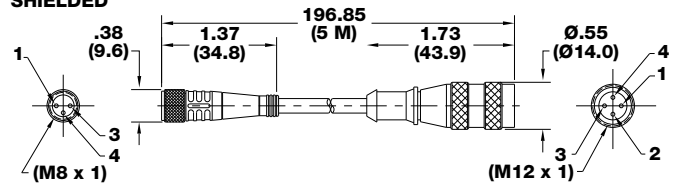

Dimensions

Shown in inches (millimeters)

Option N (No Enclosure)

PC Board

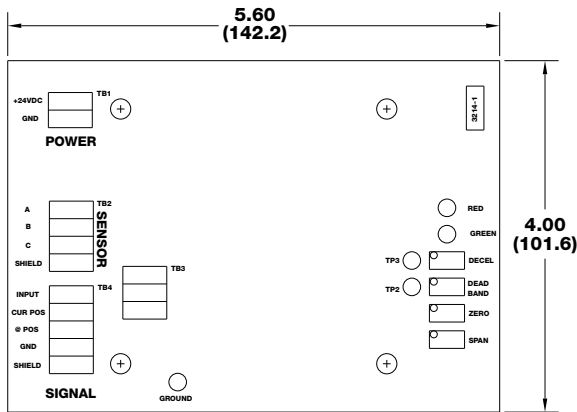

Snap Track

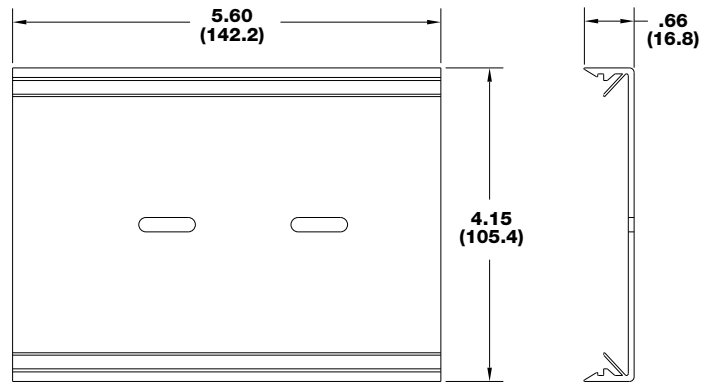

Valve/Manifold

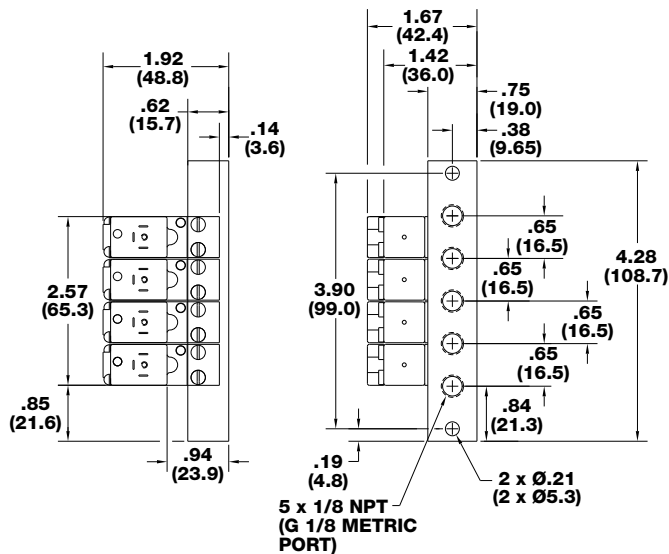

Valve Cable

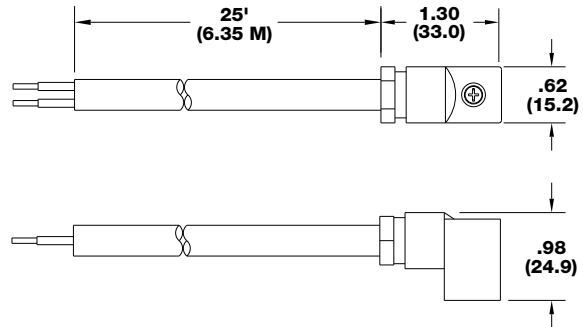

Flow Controls

Alignment Couplers

Position Feedback
Cylinder

Position Feedback
PneumTurn

Pneumatic Control
System

Digital Panel Meter

Electronic Controller

Specifications

| Description | Specification |
|-------------------------------|---|
| Zero Adjustment | 50% of total full scale output between both adjustments |
| Span Adjustment | |
| DECEL Adjustment | Approximately 0.5 to 13.5 volts |
| Deadband Adjustment | Approximately 0.005 to 0.500 volts |
| @ Position | Discrete output that sinks to ground when within deadband zone. 20mA Maximum |
| Current Position | 0 to 10 VDC signal, 1M ohm input impedance required for input device. Scaled with zero and span adjustments |
| Operation at Power Loss | All valves close at power loss |
| Input Supply Voltage | 23.5 to 24.5 VDC, 1 amp |
| Operating Pressure | 70 to 80 psig |
| Air Requirement | Regulated and filtered to 5 micron |
| Operational Temperature Range | 0 to 100 degrees F (Electronics\PC Board) |
| Reverse Polarity Protected | |
| Overvoltage Protected | |

Application Sizing and “Rules of Thumb”

PFC Cylinder/PCS Valve System Matching and Sizing Recommendations¹

| Bore Size | Model | Stroke Range | Maximum Payload | Average Velocity | Maximum External Friction | Zero Friction Deadband ² | 1/2 Maximum Friction Deadband | Maximum Friction Deadband | Minimum Step ³ |
|------------------|-------|--------------|-----------------|------------------|---------------------------|-------------------------------------|-------------------------------|---------------------------|---------------------------|
| PFC-09 (1-1/16") | PCS-1 | 2" to 7" | 1 lb. | 2.75 in/sec | zero | ±50mV | N/A | N/A | 0.080" |
| PFC-09 (1-1/16") | PCS-1 | 8" to 24" | 30 lbs. | 4.00 in/sec | 5 lbs. | ±40mV | ±80mV | ±160mV | 0.2-0.39" |
| PFC-17 (1-1/2") | PCS-1 | 1" to 3" | 2 lbs. | 2.50 in/sec | zero | ±25mV | N/A | N/A | 0.040" |
| PFC-17 (1-1/2") | PCS-2 | 4" to 24" | 50 lbs. | 5.50 in/sec | 10 lbs. | ±20mV | ±40mV | ±80mV | 2 times deadband |
| PFC-31 (2") | PCS-2 | 1" to 2" | 4 lbs. | 2.75 in/sec | zero | ±50mV | N/A | N/A | 0.020" |
| PFC-31 (2") | PCS-3 | 3" to 24" | 90 lbs. | 6.50 in/sec | 20 lbs. | ±15mV | ±30mV | ±60mV | 2 times deadband |

¹ If your application requires lower velocities or payloads, you may be able to reduce the minimum recommended deadband setting, or if your deadband requirements can accommodate a large range, you may be able to increase your payload higher than the recommended values.

² Note: The following formula can be used to convert the deadband voltage to displacement: $w = 0.1(V) \times t$, where w is the deadband width, V is deadband voltage listed above and t is full scale travel of the actuator. For example: If the deadband is set for 20mV (0.02 of a volt) for a 6 inch stroke cylinder, $w = 0.1 (0.02) \times 6 = \pm 0.012$ of an inch.

³ Minimum step is stroke dependent.

Application Sizing Cont.

Assumptions used for Sizing Values recommendations:

- Values shown in sizing table are with no overshoot. If overshoot is acceptable for your application, the deadband may possibly be less than specified. However, be sure your system cannot go unstable.
- PFC cylinder with Option L is used. (Option L has very low friction seals. The standard PFC utilizes a rod wiper which increases friction significantly, which will have adverse effects on positioning capabilities).
- 80 psi air supply.
- Minimum of 23.5 VDC provided to the PCS.
- Clean Command Signal for Main Control. (<5mV noise/ripple)
- Leak free system (The system will actually perform well with some system leakage, however, the best performance is with no leakage).
- Short (<18 inches), hard air lines (nylon) between the valves and the actuator.
- No backlash in the system.
- Horizontally guided load. The system can handle vertical or inclined loads and still meet the minimum deadband specified above, however, the velocity may be effected by up to 40%.

Typical “Rules of Thumb”:

- Deviations from the recommended parameters, such as air pressure, power supply voltage, external friction, etc, will negatively effect system performance. However, the system may still perform adequately for your application.
- Applications with loads less than 10% of actuator capacity and strokes greater than 4 inches will yield better repeatability than the minimum deadband shown in the sizing table above.
- Reducing actuator velocity by use of Flow Controls may enable the deadband to be adjusted tighter for a given application. The Flow Controls must be inserted into the exhaust ports of the valve manifold, NOT in the actuator.
- Oversizing the actuator for a given application typically yields better repeatability.
- Generically, following are relative influences on velocity:
 - As Mass increases, Velocity decreases (up to 20%)
 - As Friction increases, Velocity decreases (up to 20%)
 - As Pressure decreases, Velocity decreases (up to 20%)
- Increased Friction decreases repeatability. Maximum external friction should not exceed 20% of the maximum rated payload. Any external friction in the application will degrade system performance. Ensure the system is aligned properly to any guiding systems. Misalignment will cause external application friction.
- A borderline solution can be effective through any/all of the following:
 - sacrificing performance in one area for another,
 - limiting velocity with external flow controls,
 - employing a small central portion of a longer probe,
 - using a larger bore cylinder.
- The PCS system is not suited for applications where accurate velocity control is needed by controlling the rate of command signal change. Flow controls can be used if lower velocities are required.



Do not allow the PCS valves to stay on for prolonged time periods unless the valves are well ventilated, as they may overheat potentially causing damage to the valves.

Application Sizing

PTF Cylinder and PCS Valve System Matching and Sizing Recommendations

Single Rack Model

| PTF Single Rack Models Valve Sizing Recommendations | | | | | | |
|--|-------|------------|------------------|----------------|------------------|------------------|
| Bore | Valve | Rotation | Minimal Deadband | Maximum Torque | Average Velocity | Minimum Step |
| 1-1/2" | PCS-1 | 45° - 325° | 28 mV | 27 in.-lb. | 150° per sec. | 2 times deadband |
| 2" | PCS-2 | 45° - 325° | 28 mV | 70 in. - lbs. | 150° per sec. | 2 times deadband |

Double Rack Model

| PTF Double Rack Models Valve Sizing Recommendations | | | | | | |
|--|-------|------------|------------------|----------------|------------------|------------------|
| Bore | Valve | Rotation | Minimal Deadband | Maximum Torque | Average Velocity | Minimum Step |
| 1-1/2" | PCS-2 | 45° - 325° | 28 mV | 55 in.-lb. | 150° per sec. | 2 times deadband |
| 2" | PCS-3 | 45° - 325° | 28 mV | 135 in. - lbs. | 150° per sec. | 2 times deadband |

If your application requires lower velocities or payloads, you may be able to reduce the minimum recommended deadband setting, or if your deadband requirements can accommodate a large range, you may be able to increase your payload higher than the recommended values.

**Testing was performed with an offset load in a vertical direction. Performance will improve with a balanced payload and the plane of motion is horizontal.

Deadband voltage conversion to shaft displacement

- The following formula can be used to convert the deadband voltage to displacement:

$w = 1/10V * t$, where w = deadband width, V = voltage reading from the PCS, t = full scale travel of the actuator (Note: for PTF rotary actuators with total rotation less than 180° always make $t = 180$)

Example: If the deadband is set for 30mV (0.03 of a volt) for a 180° actuator, the width of the deadband zone will be $1/10 * .028 * 180 = \pm 0.50^\circ$.

Specification Comments

- PTF Feedback signal 0 to 10 VDC only.
- Bearing Loads - Maximum Axial and Radial loads are identical to the standard Pneu-Turn with the ball bearing option.
- Maximum Allowable Kinetic Energy is identical to the standard Pneu-Turn with Cushions.
- Refer to the PCS New Product Bulletin for additional PTF performance information.

Application

Example

The following section will review two examples, one example shows a PFC application, and the second example shows a PTF rotary example.

PFC Example

Let's say we have just finished the installation procedure for a Bimba PFC Cylinder with 10 inches of stroke, and are using a 0-10 VDC input command signal. There is a retracted hard stop at 1.5 inches of cylinder stroke and an extended hard stop at the 9.0 inches of cylinder stroke.

Therefore:

- After adjusting the Span setting, 10 volts is equivalent to 9.0 inches of cylinder rod extension.
- After adjusting the Zero setting, 1.5 inches of cylinder rod extension will equal 0 volts.

Therefore, 0 to 10 volts covers the 7.5 inch (9.0" - 1.5") range of motion .

Using the following formula:

The command signal can be translated into actuator displacement with the following formula:

$$CS = d * R / t + Z$$

where:

- CS** = the command signal required to achieve a desired position
- d** = the displacement the desired position is from the zero position
- R** = the full range of the command signal
- t** = full scale travel of the actuator (Note: for PTF rotary actuators with total rotation less than 180° always make t = 180)
- Z** = the command signal for the zero position

Application

To command the PFC to go to a position that is 2.0 inches extended from the retracted hard stop, the command signal would be calculated as follows:

$$\text{CS} = 2 \times 10/7.5 + 0 = 2.667 \text{ VDC Command Input Signal}$$

If a 4-20 mA signal is used, the command input signal would be calculated as follows:

$$\text{CS} = 2 \times 16/7.5 + 4 = 8.267 \text{ mA Command Input Signal}$$

*Note: The positional repeatability of the system will be determined by the Deadband adjustment. If the deadband was adjusted to $\pm 20\text{mV}$ in this example, the system would position to the 2 inch position within $\pm 0.015"$ ($w = 0.1 (V) * t$).*

PTF Example

Let's say we have just finished the installation procedure for a Bimba PTF Rotary actuator with 200 degrees of rotation, and a 0-10 VDC command input signal. There is a zero rotational hard stop at 10 degrees of rotation and a full scale rotational hard stop at 190 degrees of rotation.

Therefore:

- After adjusting the Span setting, 10 volts is equivalent to 190 degrees of rotation.
- After adjusting the Zero setting, 10 degrees of rotation will equal 0 volts.

Therefore, 0 to 10 volts covers 180 degrees (190 - 10) of motion .

To command the actuator shaft to rotate to a position that is 45 degrees rotated from the zero hard stop, the command voltage would be calculated as follows:

$$\text{CS} = 45 \times 10/180 + 0 = 2.50 \text{ VDC Input Command Signal}$$

If a 4-20 mA input command signal is used, the command input would be calculated as follows:

$$\text{CS} = 45 \times 16/180 + 4 = 8 \text{ mA Command Input Signal}$$

*Note: The positional repeatability of the system will be determined by the Deadband adjustment. If the deadband was adjusted to $\pm 20\text{mV}$ in this example, the system would position to the 45 degree position within ± 0.36 degrees ($w = 0.1 (V) * t$).*

DPM Series Application

Bimba Digital Panel Meter Model DPM Application Example



The DPM controller is ideal for measuring and gauging applications. The measurement repeatability, when combined with the PFC, is 0.001 inch per inch of stroke. The DPM supplies the PFC with a very accurate excitation voltage and has a 16 bit A/D converter. The DPM/PFC combination can be used as a Go/No Go gauge for in process quality control, among other things. A typical application follows:

Desired Result: In line process control verification to determine if parts meet required specifications.

Example One

The DPM is used in conjunction with a PFC cylinder to verify part specifications during an assembly process, ensuring quality of parts. RS-485 communications are used to monitor the PFC displacement remotely from the DPM. (The RS-485 protocol allows up to 32 devices to be connected to one port, and is less susceptible to signal noise since the analog to digital conversion is done in the DPM controller, utilizing the same power supply and ground planes as the PFC.) This information will be read by a PLC. The PLC determines what should be done to the part based on the displacement values read. (i.e., Send part on to the next process, or divert to rework station.) Use the DPM/PFC combination to verify if nuts are present and tightened correctly by checking the height of the nut. Calibrate the DPM using four calibration points-zero, LCL (lower control limit), UCL (upper control limit), and full scale. Refer to the Quick Start Guide, or the DPM manual shipped with each

Example Two

Read the Programmable alarm outputs of the DPM from a PLC input card. The DPM outputs can be used to determine if a part measures to the proper tolerance or not. Alarm output one can be programmed to turn on at the upper control limit (UCL) of the part specification, and alarm output two can be programmed to turn on at the lower control limit (LCL) of the part specification. When the PFC is extended to measure the part, the PLC can read the DPM setpoint alarm outputs to

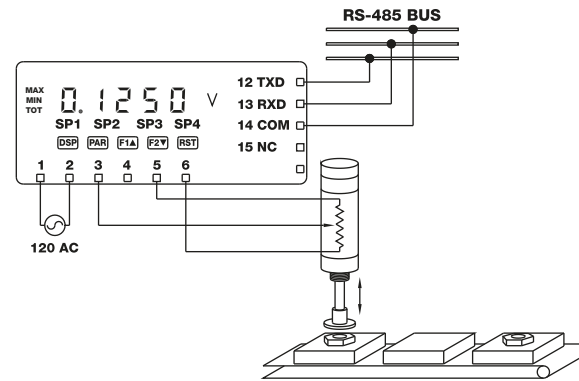

control unit for instructions. Configure the PLC with an RS-485 communication port. Program the PLC ladder logic according to your particular application. The ladder logic can be written to accommodate different sets of specifications for different product lines, making set up for the different products much easier and less time consuming.

determine if the part conforms to the proper specifications. After the PFC is extended against the part, the PLC reads the DPM outputs. If no setpoint alarm turns on, this means that the PFC displacement is above the UCL, and the part is too big. If setpoint alarm one is on, this means that the part is in the good tolerance zone. If both setpoint alarms are on, this means that the part is either too small, or the part is not present.

Model DPM - 1 / 8 DIN Universal DC Input Panel Meter

Bimba Model DPM Digital Set Point Controller

The Bimba DPM may be used with the Position Feedback Cylinder. The controller provides a digital LED readout that may be calibrated to indicate the position of the cylinder in desired units. The PFC/DPM combination is ideal for measuring and gauging applications. The controller includes the following features:

- PFC Compatible Excitation and Input Impedance
- 120 VAC Input Voltage
- 16 Point Calibration Feature for Increased PFC Linearity
- Max and Min Reading Memory
- 5 Digit Display
- Programmable Function Keys
- Optional Serial Communication, Including RS-232, RS-485 and DeviceNet®
- Optional Analog Card with 16 bit Resolution
- NEMA 4X/IP65 Sealed Front Bezel
- CE Compliant
- Fast Input and Output Rates-Programmable

General Description

The DPM embodies many features and performance capabilities to suit a wide range of indication requirements. The meter employs advanced technology for stable, drift free readout, while incorporating features that provide flexibility now and in the future with Plug-in option cards. The option cards afford the opportunity to easily configure the meter for the needs of the present while providing an upward migration path as control and indication needs evolve.

The DPM provides a precision excitation compatible for Bimba's PFC. 16-point input scaling feature improves PFC linearity if necessary. The meter provides a Max and Min reading memory with programmable capture time. The capture time is used to prevent detection of false max and min readings which may occur during start-up or unusual process events.

The signal totalizer (integrator) can be used to compute a time-input product. This can be used to provide a readout of totalized flow, calculate service intervals of motors and pumps, etc. The totalizer can also accumulate batch weighing operations.

The DPM comes standard with four sourcing setpoint outputs. The setpoint alarms can be configured in modes to suit a variety of control and alarm requirements.

- High and low absolute, high and low deviation and band acting
- Balanced or unbalanced hysteresis
- On and off delay timers
- Auto reset or latching modes
- Reverse phase output and/or panel indicator
- Selection of alternate list of setpoint values

Optional accessory cards also facilitate bus communications. These include RS232, RS485 and DeviceNet. Readout values and setpoint alarm values can be controlled through the bus.

Additionally, the meter has features that allow a remote computer to directly control the outputs of the meter. This is useful during commissioning phases and diagnostic use. With a communication card installed, set-up software allows configuration from a PC. The configuration data can be saved to a file for later recall. Contact Bimba for information if required.

Once the meter has been initially configured, the parameter list may be locked out from further modification in it's entirety or only the setpoint values can be made accessible.

The meter has been specifically designed for harsh industrial environments. With NEMA4 X/IP65 sealed bezel and extensive testing of noise effects to CE requirements, the meter provides a tough and reliable local readout.



CAUTION: Read complete instructions prior to installation and operation of the unit.



CAUTION: Risk of electric shock.

Dimensions "In Inches (mm)"

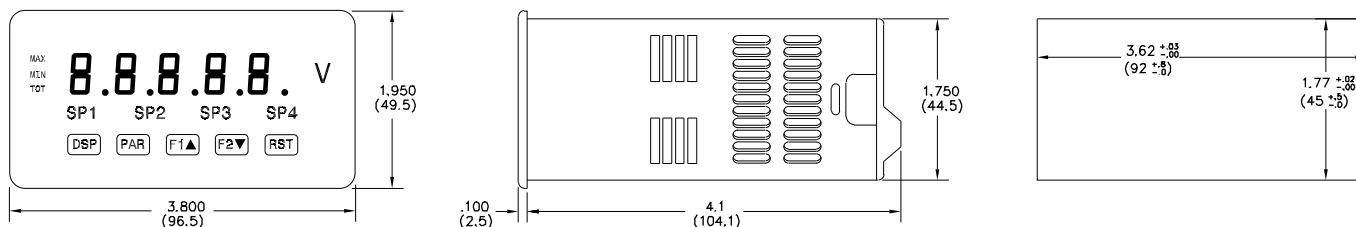

Note: Recommended minimum clearance (behind the panel) for mounting clip installation is 2.1" (53.4) H x 5.5" (140) W.

DPM Specifications

- DISPLAY:** 5 digit, 0.56" red LED, (-19999 to 99999)
- POWER:** 85 to 250 VAC, 50/60 Hz, 15 VA
Isolation: 2300 Vrms for 1 min. to all inputs and outputs.
- ANNUNCIATORS:**
MAX - max readout selected
MIN - min. readout selected
TOT - totalizer readout selected, flashes when total overflows
SP1 - setpoint alarm 1 is active
SP2 - setpoint alarm 2 is active
SP3 - setpoint alarm 3 is active
SP4 - setpoint alarm 4 is active
Units Label - software controlled units label backlight
- KEYPAD:** 3 programmable function keys, 5 keys total
- A/D CONVERTER:** 16 bit resolution
- UPDATE RATES:**
A/D conversion rate: 20/readings sec
Step response: 200 msec. max. to within 99% of final readout value (digital filter and internal zero correction disabled)
700 msec. max. (digital filter disabled, internal zero correction enabled).
The meter periodically (every 12 seconds) imposes a 500 msec delay to compensate for internal zero drift. If the delay affects applications where step response is critical, it can be defeated. Set the display update to 20/sec to disable. In this case, add a zero error of 0.1% FS over the 0 to 50°C range.
Display update rate: 1 to 20 updates/sec
Setpoint output on/off delay time: 0 to 3275 sec
Analog output update rate: 0 to 10 sec
Max./Min. capture delay time: 0 to 3275 sec
- RANGE OVERLOAD RESPONSE:**
Display flashes [LOL] at approximately 105% above range
Display flashes [ULUL] at approximately -5% below range
- DPM PFC INPUT:**

| Accuracy* (18 to 28°C) | Accuracy* (0 to 50°C) | Impedance/ Compliance | Max Continuous Overload | Resolution |
|------------------------|-------------------------|-----------------------|-------------------------|------------|
| 0.03% of reading +3 mV | 0.12% of reading + 4 mV | 1.066 Mohm | 300 V | 1mV |

* After 20 minute warm-up. Accuracy is specified in two ways: Accuracy over an 18 to 28°C and 10 to 75% RH environment; and accuracy over a 0 to 50°C and 0 to 85%RH (non-condensing environment). Accuracy over the 0 to 50°C range includes the temperature coefficient effect of the meter.

- EXCITATION POWER:**
9V ±4% initial value regulated, 130 mA max.
- LOW FREQUENCY NOISE REJECTION:**
Normal Mode: > 60 dB @ 50 or 60 Hz ±1%, digital filter off
Common Mode: >100 dB, DC to 120 Hz
- USER INPUTS (Logic Level):** Three software defined user inputs, jumper selectable for sink/source logic
Max. Continuous Input: 30 VDC

| INPUT STATE | SINKING INPUTS (DEFAULT) | SOURCING INPUTS |
|-------------|----------------------------|----------------------------|
| | 22 K pull-up to +5 V | 22 K pull-down |
| Active | $V_{IN} < 0.7 \text{ VDC}$ | $V_{IN} > 2.5 \text{ VDC}$ |
| Inactive | $V_{IN} > 2.5 \text{ VDC}$ | $V_{IN} < 0.7 \text{ VDC}$ |

Isolation To Sensor Input Common: Not isolated

- TOTALIZER:**
Time Base: second, minute, hour, or day
Time Accuracy: 0.01% typical
Decimal Point: 0 to 0.0000
Scale Factor: 0.001 to 65.000
Low Signal Cut-out: -19,999 to 99,999

Total: 9 digits, display alternates between high order and low order readouts

- CUSTOM LINEARIZATION:**
Data Point Pairs: Selectable from 2 to 16
Display Range: -19,999 to 99,999
Decimal Point: 0 to 0.0000
- SERIAL COMMUNICATIONS:** (RS232 or RS485)
Isolation To Sensor & User Input Commons: 500 Vrms for 1 min.
Working Voltage: 50 V
Not Isolated from all other commons.
Data: 7/8 bits
Baud: 300 to 19200
Parity: no, odd or even
Bus Address: selectable 0 to 99, Max. 32 meters per line (RS485)
Transmit Delay: Selectable for 2 to 50 msec or 50 to 100 msec (RS485)
- ANALOG OUTPUT :**
Types: 0 to 20 mA, 4 to 20 mA or 0 to 10 VDC
Isolation To Sensor & User Input Commons: 500 Vrms for 1 min.
Working Voltage: 50 V
Not Isolated from all other commons.
Accuracy: 0.17% of FS (18 to 28°C); 0.4% of FS (0 to 50°C)
Resolution: 1/3500
Compliance: 10 VDC: 10 K load min.
20 mA: 500 W load max.
- Quad Sourcing Open Collector:** (Standard with DPM):
QUAD SOURCING OUTPUT FIELD TERMINALS

| | |
|----|-------------------|
| 20 | - EXTERNAL SUPPLY |
| 21 | - 01 SRC. |
| 22 | - 02 SRC. |
| 23 | - 03 SRC. |
| 24 | - 04 SRC. |
| 25 | - COMMON |

Type: Four isolated sourcing PNP transistors.
Isolation To Sensor & User Input Commons: 500 Vrms for 1 min.
Working Voltage: 50 V
Not Isolated from all other commons.
Rating: Internal supply: 24 VDC ± 10%, 30 mA max. total all four outputs.
External supply: 30 VDC max., 100 mA max. each output.

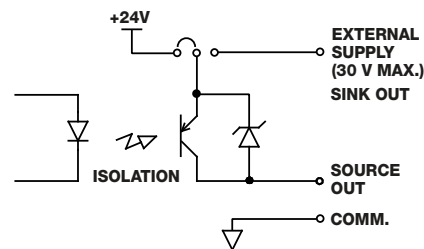
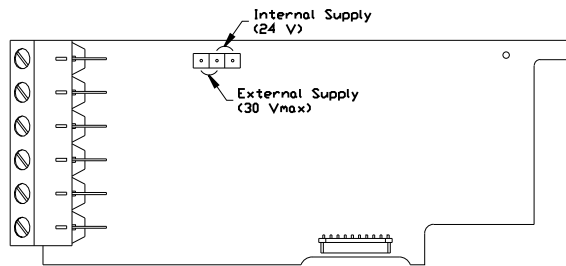

DPM Specifications Cont.

Optional Quad Relay Card:

(Optional Accessory Card DPM-R):

QUAD RELAY OUTPUT FIELD TERMINALS

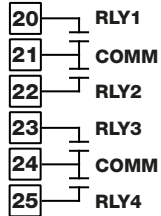

Type: Four FORM-A relays
Isolation To Sensor & User Input Commons: 2300 Vrms for 1 min.
Contact Rating: One Relay Energized: 3 amps @ 250 VAC or 30 VDC (resistive load), 1/10 HP @120 VAC, inductive load. Total current with all four relays energized not to exceed 4 amps
Life Expectancy: 100K cycles min. at full load rating. External RC snubber extends relay life for operation with inductive loads.

17. ENVIRONMENTAL CONDITIONS:

Operating Temperature Range: 0 to 50°C (0 to 45°C with all three plug-in cards installed)
Storage Temperature Range: -40 to 60°C
Operating and Storage Humidity: 0 to 85% max. non-condensing
Altitude: Up to 2000 meters

18. CERTIFICATIONS AND COMPLIANCES: ELECTROMAGNETIC COMPATIBILITY

Notes:

1. Self-recoverable loss of performance during EMI disturbance at 10 V/m: Measurement error less than 2% of full scale.

For operation without loss of performance:

Mount unit in a metal enclosure (Buckeye SM7013-0 or equivalent)
 Route power and I/O cables in metal conduit connected to earth ground.

Refer to the Application Guide for additional EMC information.

Immunity to EN 50082-2

| | | |
|-----------------------------------|--------------|---|
| electrostatic discharge | EN 61000-4-2 | level 3; 8 Kv air |
| electromagnetic RF fields | EN 61000-4-3 | level 3; 10 V/m ¹ 80 MHz - 1 GHz |
| fast transients (burst) | EN 61000-4-4 | level 4; 2 Kv I/O level 3; 2 Kv power |
| RF conducted interference | EN 61000-4-6 | level 3; 10 V/rms 150 KHz - 80 MHz |
| simulation of cordless telephones | ENV 50204 | level 3; 10 V/m 900 MHz ±5 MHz 200 Hz, 50% duty cycle |

Emissions to EN 50081-2

| | | |
|-----------------|----------|--|
| RF interference | EN 55011 | enclosure class A power mains class A |
|-----------------|----------|--|

19. **CONNECTIONS:** High compression cage-clamp terminal block
Wire Strip Length: 0.35" (9 mm)
Wire Gauge Capacity: One 14 AWG solid or Two 18 AWG

20. **CONSTRUCTION:** This unit is rated for NEMA 4X/IP65 indoor use. IP20 Touch safe. Installation Category II, Pollution Degree 2. One piece bezel/case. Flame resistant. Synthetic rubber keypad. Panel gasket and mounting clip included.

21. **WEIGHT:** 10.4 oz. (295 g)



Safety Summary

All safety related regulations, local codes and instructions that appear in the manual or on equipment must be observed to ensure personal safety and to prevent damage to either the instrument or equipment connected to it. If equipment is used in a manner not specified by the manufacturer, the protection provided by the equipment may be impaired. Do not use this unit to directly command motors, valves, or other actuators not equipped with safeguards. To do so can be potentially harmful to persons or equipment in the event of a fault to the unit.

Jumper Link Functions

FRONT

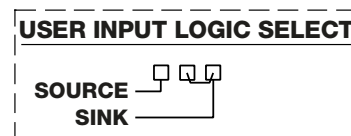

User Input Source or Sink Select

Front Panel

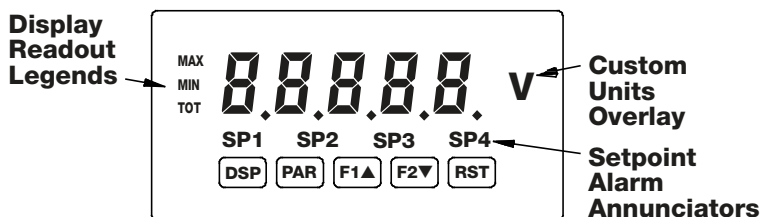

KEY DISPLAY MODE OPERATION

| | |
|-----|--|
| DSP | Index display through max/min/total/input readouts |
| PAR | Access parameter list |
| F1 | Function key #1; hold for 3 seconds for Second Function #1 |
| F2 | Function key #2; hold for 3 seconds for Second Function #2 |
| RST | Reset (function key) |

PROGRAMMING MODE OPERATION

| |
|--|
| Quit programming and return to display mode |
| Store selected parameter and index to next parameter |
| Increment selected parameter value |
| Decrement selected parameter value |
| Hold with F1, F2 to scroll value by x1000 |

Basic Connections

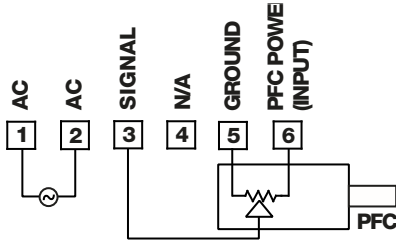

Note: Option card field connections are supplied with the card.

Wire Colors

| Wires | 6" Leads | Plug |
|--------|----------|-------|
| Input | Red | Blue |
| Ground | Black | Black |
| Output | White | Brown |

Custom Units Overlay

The meter has a backlighted units indicator that can be customized to the application. The backlight is turned on by programming the "b-l t" parameter. Overlays are available in the Units Label Kit. To install an overlay, remove the unit from the case. Select the label and apply it to the label frame, noting that the label must be aligned accurately. Install the label frame to the display board in the alignment holes located on the right side of the display.

Plug-In Cards

The meter has three plug-in card slots. Each slot is dedicated to a specific function. These functions are:

- **Setpoint Outputs**
- **Analog Outputs**
- **Communication Option**

The plug-in cards can be used in any combination, however, it is only possible to use one type of card from each category. Cards can be installed initially, or at a later date as system needs arise.

Devicenet Plug-In Card

A DeviceNet communication port can be added to the meter. DeviceNet is a high level bus protocol based upon the CAN specification. The protocol allows the integration of devices of different types and manufacturers within a common communication framework.

Analog Output Plug-In Card

The analog output is available as a Plug-in card. Either the 20 mA or the 10 V output can be used. The output can be scaled independent of the input range. Reverse acting output is possible by reversing the scaling point positions. Other features are selectable update rate and output source selection.

RS485 Plug-In Card

An RS485 communication port can be added with a Plug-in card. RS485 offers multi-drop bus communications. All devices connect in parallel on a 485 bus. Only one device is permitted to transmit at any one time, while all other devices are in receive mode. The meter controls the bus when it transmits data, otherwise the meter is in the receive mode.

RS232 Plug-In Card

An RS232 communication port can be installed with a Plug-in card. RS232 is intended to allow only 2 devices to communicate to each other (i.e., printer or computer). For more information, See DPM Serial Application Guide.

Inputs

Voltage Inputs

The Bimba PFC uses the $\pm 20V$ range (default).

Scaling

The meter has been factory calibrated on all ranges as a basic multimeter (voltmeter/ammeter/ohmmeter). The basic meter readout can then be post scaled to read out in the process units (level, flow, temperature, etc.). The meter provides two ways in which to scale the display:

Key-in: Key in the input and display scaling points using known data.

Apply: Apply the actual input value and key in the corresponding display value. The meter records the input value applied.

For processes that require linearity compensation, up to 16 scaling points can be used for correction. The scaling range is extended up to five digits of resolution with selectable display rounding factors.

Input Features

A unique adaptive input filter is used. Whenever the difference between one reading and the next is less than the filter band value, the input is filtered. When the difference exceeds the filter band value, the input is not filtered. This avoids the usual compromise between using a relative high time constant for good noise rejection and using a low time constant filter for quick step response.

The readout can be corrected for process zero errors with an offset value. A tare function zeros the readout via a function operation.

Function Keys and User Inputs

The Function Keys and User inputs can be programmed to perform specific meter control operations. Function Keys #1 and #2 each have two types of functions, primary and secondary. The primary function is executed the instant the key is pressed. Holding the key for three seconds executes the second function. If the key is not held for 3 seconds, the second function is not executed. To implement a hidden key, program no function for the primary and program the desired function for the second.

The three user inputs can be selected for sinking or sourcing logic.

Max and Min Reading Detection

The meter records the maximum (max) and minimum (min) process inputs. Conditions such as valve activation, sudden change in material flow rate, etc., can result in false peaks which are not reflective of the true maximum and minimum of the process. In this case, Max and Min capture delay times can be used to prevent the detection of false maximums and minimums.

Basic Connections

Parameter Lock Mode

A user input can be used to lock the parameter list. When the user input is active, the meter is in the protected parameter mode, where it is only possible to access the setpoint values and the security code.

It is possible to lock the parameter list without using a user input as a program lock function. In this case, set the security code to a non-zero value. With a non-zero security value set, press the PAR Key to view the programmed setpoint values. The security code requires a “key” value to gain access to the full parameter list.

Installation

The DPM meets NEMA 4X/IP65 requirements for indoor use when properly installed. The unit is intended to be mounted into an enclosed panel. Prepare the panel cutout to the dimensions shown in the Dimensions drawing. Remove the panel latch and cardboard sleeve from the unit and discard the cardboard sleeve. Slide the panel gasket over the rear of the unit to the back of the bezel. The unit should be installed fully assembled. Insert the unit into the panel cutout. While holding the unit in place, push the panel latch over the rear of the unit so that the tabs of the panel latch engage in the slots on the case. The panel latch should be engaged in the farthest forward slot possible. To achieve a proper seal, tighten the latch screws evenly until the unit is snug in the panel (Torque to approximately 7 in-lbs [79N-cm]). Do not over-tighten the screws.

Ordering Information

| Model Number | Description | List Prices |
|--------------|---|-------------|
| DPM | Base Unit - Includes Excitation, Quad Solid State Outputs | \$410.00 |
| DPMA | Base Unit with Analog Card | 495.00 |
| DPMS | Base Unit with RS-485 Serial Output | 480.00 |
| DPM-485 | RS-485 Plug-In Accessory Card | 70.00 |
| DPM-232 | RS-232 Plug-In Accessory Card | 70.00 |
| DPM-DNET | DeviceNet Plug-In Accessory Card | 170.00 |
| DPM-A | Analog Plug-In Accessory Card | 110.00 |
| DPM-R | Quad Form A 120 VAC Relay Plug-In Accessory Card | 70.00 |

Electronic Controller

The Bimba Electronic Controllers provide 10 VDC regulated power to the Position Feedback Cylinder. Four models are available for AC or DC input and voltage or current output. Each controller offers both dual set point and scaled analog output functions. The controllers are strictly analog in nature and are **not** closed loop motion controllers.

The Bimba electronic controller is ideal for applications where:

- The main system controller being used to interface with the PFC does not have the required 1 Mohm input impedance.
- Accuracy is not a key consideration (\pm 0.030" or higher).
- The application requires a fast responding scaleable analog output signal.
- The customer desires to cycle between two variable set points without needing to stop and hold a position.

Typical applications include web tensioning or dancer arm control. The Bimba electronic controller would be used as an interface between the PFC cylinder and the customers web tensioning or dancer arm controller.

| Model | Input Power | Scalable Output |
|---------------|-------------|-----------------|
| 120AC4-20mA | 120 VAC | 4 - 20 mA |
| 120AC0-10DC | 120 VAC | 0 - 10 VDC |
| 12/24DC4-20mA | 12-24 DC | 4 - 20 mA |
| 12/24DC0-10DC | 12-24 DC | 0 -10 VDC |

List Prices

| Model | Price |
|---------------|----------|
| 120AC4-20mA | \$210.00 |
| 120AC0-10DC | \$210.00 |
| 12/24DC4-20mA | \$240.00 |
| 12/24DC0-10DC | \$240.00 |

All prices are F.O.B. Monee, Illinois and are subject to change without notice.

Dimensions

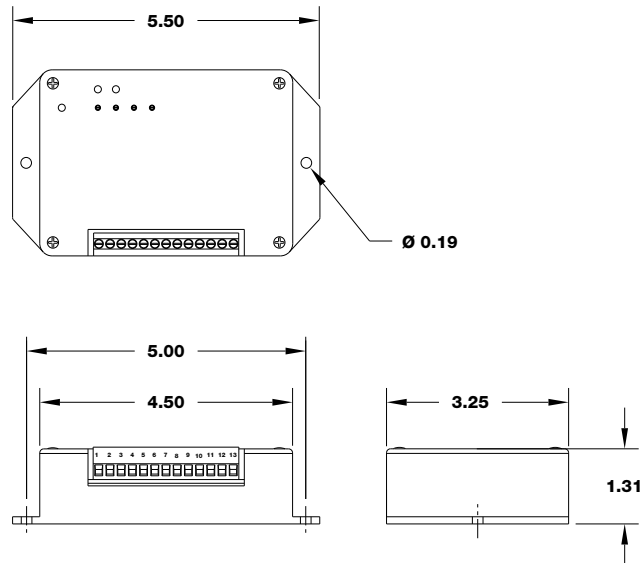

Electronic Controller Specifications

Auxiliary Power Requirement:

| | |
|-----------------|----------------------------------|
| AC Models | 100 to 135 VAC (115 VAC Input) |
| | 200 to 270 VAC (230 VAC Input) |
| DC Models | 11.8 to 26 VDC (12/24 VDC Input) |

Power Requirement:

| | |
|-----------------|-------------------------------|
| AC Models | 5 VA maximum (120 to 230 VAC) |
| DC Models | 1.2 VA maximum (12 VDC) |
| | 2.4 VA Max (24 VDC) |

Frequency Range 50/60 HZ

Transducer Excitation Voltage 10 VDC (Nominal)

Electrical Connections 13 position Euro Style terminal block

Dielectric Strength:

| | |
|-----------------|--|
| AC Models | 2000 VAC (All Inputs to all Outputs) |
| | 2000 VAC (Terminals to case) |
| DC Models | 2000 VAC (All Inputs to relay Outputs) |
| | 2000 VAC (terminals to Case) |

Note: The Negative power supply connection is common to the analog signal output.

Transient Protection All inputs and outputs are designed to withstand transient energy levels normally associated with Category III service locations as defined by IEC 644. Industrial installations that are typical of this environment would include most distribution, feeder or branch circuit connections that are not located at the immediate service entrance.

Shipping Weight Approx. 12 oz.

Operating Temperature Range (-30 C to +70 C) -22 F to 160 F
(0 C to +70 C) 32 F to 160 F for 12 VDC Operation

Storage Temperature Range (-40 C to +85 C) -40 F to 185 F

Enclosure Dimensions 1.31" H x 5.50" W x 3.25" D

Electronic Controller Specifications

Position Feedback Control Module

Unless noted otherwise:

| | | |
|-----------------------|---|---------------------|
| Ambient Temperature | = | (25 C) 77 F Nominal |
| Aux Power (AC Models) | = | 120 VAC, 60 HZ |
| Aux Power (DC Models) | = | 24 VDC |

Relay Outputs

| | | |
|---|-------|--|
| Control Limit Set Point Range | | 2 independent adjustments settable from 0 to 100% of cylinder stroke |
| Temperature Influence on Control Limits | | $\pm 0.01\%$ stroke / C (-30 C to +70 C) |
| Output Contact Ratings | | 5 A, 250 VAC, 0.8 power factor (general use) 5 A, 30 VDC (resistive) 360 VA, 240V, 0.4 power factor (Pilot Duty) |
| Output Contact Configuration | | 2 independent form C (SPDT) relays Each relay has a corresponding control limit set point adjustment |
| Response Time (Excluding Bounce) | | |
| Operate Time | = | 8 mS TYP/12 mS maximum |
| Release Time | = | 4mS TYP/6 mS maximum |
| Mechanical Life | | 20,000,000 operations minimum |

Analog Outputs

| | | |
|---|-------|---|
| Output Load Specifications | | 0 to 10 VDC @ 10 mA maximum 4 to 20 mA @ 500 maximum loop resistance 350 for 12 VDC input |
| Zero Offset Adjustment Range | | $\pm 5V$ (10 VDC output) $\pm 8mA$ (4 to 20 mA output) |
| Gain Adjustment Range | | From 0.5 to 2.0 times input signal |
| Output Limits | | 13v typical (10 VDC output) 25mA typical (4 to 20 mA output) |
| Temperature Influence on Analog Output | | $< \pm 0.02\%$ Full Scale Output / C (-30 C to +70 C) |
| Output Ripple | | $< 0.2\%$ of Full Scale Output |
| Response Time (0 to 90% of final value) | | |
| 0 to 10 VDC | = | 2mS TYP/3 mS maximum |
| 4 to 20 mA | = | 2 mS TYP/3 mS maximum |