



AIRPICKER[®] AIRGRIPPER[™]

END-EFFECTORS



ENGINEERING MANUAL & DESIGN GUIDE



Firestone

World's Number 1
Air Spring.



FIRESTONE INDUSTRIAL PRODUCTS COMPANY

TABLE OF CONTENTS

Introduction	2	Construction	13
Advantages	3	Body	14
Conform To Any Shape	3	Rubber Bladder Material	15
Multiple Sizes Handled with One End Effector		Fabric Reinforcement	15
Delicate Handling	3	Miscellaneous Constructions & Models	16
Wide Size Range	3	High Load Capacity AirPicker®	16
High Load Capacity	3	Low Radial Displacement AirPicker®	16
Non-marring Contact	3	Low Profile AirGripper™	16
No Lubrication Required	3	Grippie	14
Low Cost	3	Alternative Rubber Material	16
Long Life in a Dusty Environment	3	Fabric Reinforced AirGripper™	17
Precautions	4	Large AirPicker® & AirGripper™	17
Pressure	4	Accessories	18
Media	4	Nose Cones	18
Temperature	4	Protective Sleeves	18
Contact Surface	4	Rebuild Program	18
Minimum and Maximum Working Diameter	4	Selection Procedure	19
Unrestricted Inflation	5	Determining Required Pressure for	
Preconditioning	5	Heavy Loads	19-20
Contaminates	5	Determining Required Pressure for	
Storage	5	Light Loads	20
Chemical Compatibility Chart	6-8	Applications	21
Performance Characteristics	9	Selection Guide & Index	22
Load Capacity	9	Individual Data Sheets	23-38
Coefficient of Friction	10	Design Parameter Sheet	40 & 42
Life	10	Picking Inside an Object	40
Diameter vs Pressure	11	Gripping Outside an Object	42
Cycle Rate	11		
Body Tolerances	11		
Repeatability	12		
Centering & Positioning	12		
Rotational Displacement	12		

PLEASE NOTE:

The information contained in this publication is intended to provide a general guide to the characteristics and applications of these products. The material, herein, was developed through engineering design and development, testing and actual applications and is believed to be reliable and accurate. Firestone, however, makes no warranty, expressed or implied, of this information. Anyone making use of this material does so at his own risk and assumes all liability resulting from such use. It is suggested that competent professional assistance be employed for specific applications.

INTRODUCTION

The products of years of development, AirPicker® and AirGripper™ end-effectors combine pneumatic pressure control with the physical attributes of rubber. The result is an innovation that can give robotics or mechanical handling systems an important degree of touch and allow products to be handled securely and gently. The AirPicker® end-effector is inserted into a product while deflated, then inflates outwardly to "hold on to" the product's interior walls. The AirGripper™

end-effector collars around the product, then the sleeve inflates inwardly to form a grip around the product's exterior. Models are available with various inflation pressures to handle light to heavy loads. This cushioned transporting can help eliminate damage, breakage, and other processing problems. AirPicker® and AirGripper™ end-effectors have already been proven in assembly, loading, shifting, conveying and many other manufacturing operations around the world.



A D V A N T A G E S

Conform to Any Shape

The inflatable rubber construction of AirPicker® and AirGripper™ end-effectors allows a multiple number of shapes to be handled with one model.

Multiple Sizes Handled with One Gripper

The large expansion of Firestone end-effectors allows for multiple part sizes to be handled with just one size model. The diameter of an AirPicker® end-effector can grow by as much as 1.86 times the deflated diameter, while an AirGripper™ end-effector can grip around an object that is only 40% of the deflated diameter.

Delicate Handling

By controlling the amount of pressure within the bladder, Firestone end-effectors can handle delicate objects with the soft touch of rubber and air. The holding force is distributed over a greater surface area than a mechanical gripper, resulting in a soft and secure touch even with heavy loads.

High Load Capacity

The wide contact area associated with an AirGripper™ and AirPicker® end-effector results in a higher load capacity. A mechanical gripper only contacts the small area with its "fingers". The greater contact area results in a firmer grip and higher load carrying ability.

Non-marring Contact

The soft touch of the rubber and air allows for glass and plastic objects to be handled without marring their surface. This has been proven in applications handling freshly molded test tubes, glass bottles, and photosensitive copier drums.



Wide Size Range

Our standard AirPicker® end-effector line can handle objects with an inside diameter as small as 0.33 inches (8.5mm), and as large as 4.13 inches (105mm). Our standard AirGripper™ end-effector line can handle objects ranging from 0.2 to 1.8 inches (5 to 45mm) in outside diameter.

No Lubrication Required

The absence of bearings or moving parts means that no lubrication is required for a long durable life.

Low Cost

Firestone AirPicker® end-effectors typically cost less than comparable mechanical grippers.

Long Life in a Dusty Environment

The AirPicker® and AirGripper™ end-effectors do not use seals or bearings, which results in a more durable gripper in dusty environments.

PRECAUTIONS

Maximum Recommended Working Pressure

AirPicker[®] and AirGripper[™] end-effectors should not be used beyond their maximum recommended working pressure. This pressure varies depending on the fabric reinforcement and rubber material.

Standard Neoprene Construction			
P006 – P009 with standard radial fabric reinforced neoprene	55PSI	(4bar)	
P010 – P025 with standard radial fabric reinforced neoprene	70PSI	(5bar)	
P035 – P055 with standard bias fabric reinforced neoprene	70PSI	(5bar)	
G020 – G050 with standard all neoprene (no fabric reinforcement)	20PSI	(1.5bar)	

High Temperature Silicone Construction			
P014 – P035 with radial fabric reinforced silicone	25PSI	(1.8bar)	
G020 – G050 with all silicone (no fabric reinforcement)	15PSI	(1bar)	

Contact Surface

The preferred contact surface for AirPicker[®] and AirGripper[™] end-effectors is smooth and dry. A dry surface is preferred to optimize the load carrying capacity of end-effectors. Wet surfaces will decrease the grip that an end-effector has on a handled object. A smooth surface is preferred to avoid abrasion. Threads, burrs, or sharp contact areas will hasten wear and decrease the useful life of the rubber bladder. Protective neoprene sleeves for AirPicker[®] end-effectors are available to increase the life of the bladder when the contact surface conditions are abrasive (page 18).

Minimum and Maximum Working Diameter

The maximum working diameter range given for each end effector insures a secure hold on the object as well as maximizing the life of the rubber. *Exceeding this diameter range will increase the strain on the rubber and cause premature damage. Using an end-effector below the working diameter range may allow the rubber to be abraded as it is placed into and removed from the handled object.* When the clearance between the work piece and the end-effector approaches the minimum recommended, a protective nose cone for the AirPicker[®] end-effector is suggested (page 18).

Media

Air or nitrogen is an effective media to inflate Firestone end effectors.

Temperature

The minimum and maximum recommended working temperatures for the following rubber materials are:

- Neoprene 0°F to 165°F (-18°C to 74°C)
- Silicone -22°F to 320°F (-30°C to 160°C)

P R E C A U T I O N S C O N T I N U E D***Unrestricted Inflation***

Repeated unrestricted inflation will prematurely damage a Firestone end effector. The cycle life of an unrestricted Firestone end-effector can be as low as 1000 cycles. Because of the decreased durability of an unrestricted bladder, the maximum recommended pressure for unrestricted inflation

drops to half of the maximum recommended pressure for restricted inflation. If the application requires unrestricted inflation, a protective rubber sleeve or a casing surrounding the bladder is recommended. The sleeve or casing will reduce the amount of strain on the rubber bladder.

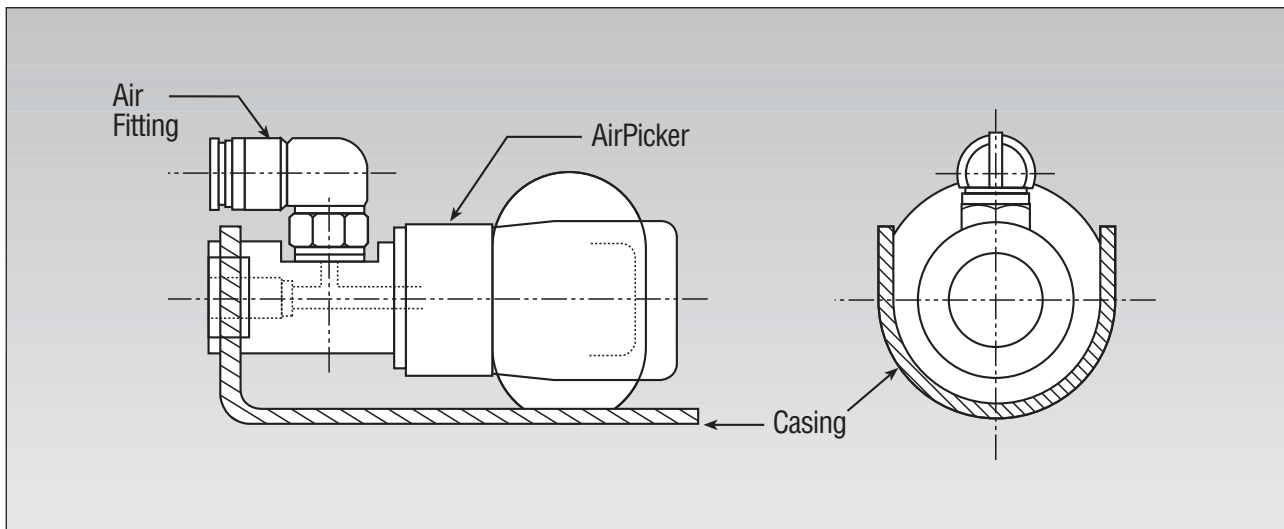
***Preconditioning***

All of the fabric reinforced rubber bladders have small cotton threads, called pick cords, used to hold the nylon fabric cords together during production. Before end-effectors are able to reach recommended working diameters, these pick cords must be broken through preconditioning. In order to break these pick cords, end-effectors must be inflated unrestricted at the maximum recommended working pressure for 30 cycles. NOTE: Excessive unrestricted inflation will harm the rubber. Be sure NOT TO HOLD pressure for an extended period when preconditioning.

Contaminates

Neoprene and silicone each have their advantages and disadvantages when in contact with lubricants, acids, solutions, etc. The chemical resistance chart on pages 6-8 gives a general idea of the chemical compatibility of these rubber materials. Please contact Firestone with specific applications.

Storage

The best long-term storage environment is a dark, dry area at normal room temperature.

CHEMICAL COMPATIBILITY CHART

The items shaded in this chart are those that are highly compatible with the particular elastomer. If a chemical is not listed, please consult your Firestone Regional Sales Manager or the Applications Engineer for the level of compatibility.

A	Neoprene	Silicone	B continued	Neoprene	Silicone	C continued	Neoprene	Silicone
Acetaldehyde			Beer			Cottonseed Oil		
Acetic Acid, 5%			Beet Sugar Liquids			D		
Acetic Acid, 30%			Benzenesulfonic Acid			Denatured Alcohol		
Acetic Anhydride			Blast Furnas Gas			Detergent Solution		
Aero Lubriplate			Borax			Developing Fluids (Photo)		
Alum-NH3CrK			Boric Acid			Diethylene Glycol		
Aluminum Bromide			Brine			Dow Corning 3		
Aluminum Chloride			Butane			Dow Corning 4		
Aluminum Fluoride			Butanol (Butyl Alcohol)			Dow Corning 5		
Aluminum Nitrate			C			Dow Corning 11		
Aluminum Phosphate			Calcium Bisulfite			Dow Corning 33		
Aluminum Salts			Calcium Carbonate			Dow Corning 44		
Aluminum Sulfate			Calcium Chloride			Dow Corning 55		
Ammonia Anhydrous			Calcium Cyanide			Dow Corning 200		
Ammonia Gas, Cold			Calcium Hydroxide			Dow Corning 220		
Ammonia Gas, Hot			Calcium Nitrate			Dow Corning 510		
Ammonium Carbonate			Calcium Phosphate			Dow Corning 550		
Ammonium Chloride			Calcium Salts			Dow Corning 1208		
Ammonium Hydroxide (Concentrated)			Calcium Silicate			Dow Corning 4050		
Ammonium Nitrite			Calcium Sulfide			Dow Corning 6620		
Ammonium Persulfate Solutions			Calcium Sulfite			Dow Corning F60		
Ammonium Persulfate 10%			Calcium Thiosulfate			Dow Corning F61		
Ammonium Phosphate			Caliche Liquors			Dow Corning XF60		
Ammonium Phosphate Mono-Basic			Cane Sugar Liquors			Dow Guard		
Ammonium Phosphate Dibasic			Carbon Monoxide			Drinking Water		
Ammonium Phosphate Tribasic			Carbon Acid			E		
Ammonium Salts			Castor Oil			Epoxy Resins		
Ammonium Sulfate			Cellugard			Ethanol		
Ammonium Sulfide			Cellulube 90, 100, 150, 220, 300, 500			Ethyl Alcohol		
Amyl Alcohol			Chloroacetic Acid			Ethyl Hexanol		
Amyl Borate			Chrome Alum			Ethyl Silicate		
Anhydrous Ammonia			Citric Acid			Ethylene Diamine		
Aroclor 1260			Cobalt Chloride			Ethylene Glycol		
Arsenic Acid			Cobalt Chloride, 2N			F		
ASTM Oil #1			Cocoonut Oil			FC-43 Heptacosofluorotri-butylamine		
B			Coffee			FC75 Fluorocarbon		
Barium Chloride			Coolanol (Monsanto)			Ferric Chloride		
Barium Hydroxide			Copper Chloride			Ferric Nitrate		
Barium Salts			Copper Cyanide			Ferric Sulfate		
Barium Sulfate			Copper Salts			Fish Oil		
Barium Sulfide			Copper Sulfate			Fluoroboric Acid		
			Copper Sulfate, 10%			Fluorolube		
			Copper Sulfate, 50%			Fluoroboric Acid		
			Corn Oil					

CHEMICAL COMPATIBILITY CHART CONTINUED

F	Neoprene	Silicone	H continued	Neoprene	Silicone	M continued	Neoprene	Silicone
Formic Acid			Hydrogen Sulfide Wet, Cold			Milk		
Freon 12			I			Mobil Nyvac 20 and 30		
Freon 13			Isobutyl Alcohol			Monomethylether		
Freon 13B1			Isopropanol			Mustard Gas		
Freon 14			Isopropyl Alcohol			N		
Freon 22			K			Natural Gas		
Freon 31			Ket F Liquids			Nickel Chloride		
Freon 32			L			Nickel Salts		
Freon 113			Latic Acids			Nickel Sulfate		
Freon 114			Lead Nitrate			Niter Cake		
Freon 114B2			Lead Sulphamate			Nitric Acid Dilute		
Freon 115			Lime Sulphur			Nitrogen		
Freon 142B			Linseed Oil			O		
Freon 152a			M			Oronite 8200		
Freon 218			Magnesium Chloride			Oronite 8515		
Freon C316			Magnesium Sulphate			OS 45 Type III (OS45)		
Freon C318			Magnesium Sulphite			OS 45 Type IV (OS45-1)		
Freon 502			Magnesium Salts			OS 70		
Freon TF			MCS 312			Oxygen, Cold		
Freon TA			Mercuric Chloride			Ozone		
Freon TC			Mercury			P		
Freon T-P35			Methanol			Parker O Lube		
Freon PCA			Methyl Alcohol			Peanut Oil		
Fuel Oil, Acidic			Methyl Ether			N-Pentane		
Fuel Oil, #6			MIL-L2105B			Potassium Chloride		
Fyrquel 90, 100, 150, 220, 300, 500			MIL-G-2108			Potassium Cupro Cyanide		
G			MIL-S3136B, Type 4			Potassium Cyanide		
Gelatin			MIL-F-5566			Potassium Dichromate		
Glucose			MIL-L6086B			Potassium Nitrate		
Glycerine-Glycerol			MIL-A-6091			Potassium Salts		
Glycols			MIL-I-8660B			Potassium Sulphate		
Green Sulphate Liquor			MIL-E-9500			Potassium Sulphite		
Gulf FRG-Fluids			MIL-L-14107B			Prestone Antifreeze		
Gulf FRP-Fluids			MIL-L-15018B			Propyl Alcohol		
H			MIL-L-15019C			Pydraul 30E, 50E, 65E, 90E		
Hannifin Lube A			MIL-L-17672B			S		
Heavy Water			MIL-L-18486A			Sal Ammoniac		
Hellum			MIL-G-18709A			Salt Water		
N-Hexaldehyde			MIL-G-21568A			Santo Safe 300		
High Viscosity Lube, U4			MIL-L-22396			Silicate Esters		
High Viscosity Lube, H2			MIL-L-26087A			Silicone Greases		
Hydrogen Gas, Cold			MIL-G-27343			Silicone Oils		
Hydrogen Gas, Hot			MIL-L-27694A			Silver Nitrate		
Hydrogen Peroxide (1)			MIL-H-46001A			Soap Solutions		
Hydrogen Sulfide Dry, Cold			MIL-L-46002			Soda Ash		
			MIL-S-81087					

CHEMICAL COMPATIBILITY CHART CONTINUED

S continued	Neoprene	Silicone
Sodium Bicarbonate (Baking Soda)		
Sodium Bisulfite		
Sodium Borate		
Sodium Carbonate		
Sodium Chloride		
Sodium Cyanide		
Sodium Phosphate (Mono)		
Sodium Phosphate (Tribasic)		
Sodium Salts		
Sodium Silicate		
Sodium Sulphate		
Sodium Sulphide		
Sodium Sulfite		
Sodium Thiosulfate		
Soybean Oil		
Spry		
Stannous Chloride		
Sucrose Solutions		
Sulfur		
Sulfur Hexafluoride		

T	Neoprene	Silicone
TT-S-735, Type IV		
Tannic Acid 10%		
Tartaric Acid		
Triethanol Amine		
U		
Ucon Lubricant LB-65		
Ucon Lubricant LB-135		
Ucon Lubricant LB-285		
Ucon Lubricant LB-300		
Ucon Lubricant LB-625		
Ucon Lubricant LB-1145		
Ucon Lubricant 50-HB55		
Ucon Lubricant 50-HB100		
Ucon Lubricant 50-HB260		
Ucon Lubricant 50-HB660		
Ucon Lubricant 50-HB5100		
Ucon Oil LB-385		
Ucon Oil LB-400X		
Ucon Oil 50-HB-280X		

V	Neoprene	Silicone
VV-G-632		
VV-G671c		
VV-O-526		
Vegetable Oil		
Versilube		
Vinegar		
W		
Water		
Whiskey and Wines		
Wood Alcohol		
X		
Xenon		
Z		
Zinc Chloride		
Zinc Salts		
Zinc Sulfate		

PERFORMANCE CHARACTERISTICS

Load Capacity

The amount of load an end-effector can handle is a function of pressure, contact area, and coefficient of friction. This function equals the frictional force.

$$F_f = P \times A \times \mu$$

F_f = Frictional Force
 P = Pressure
 A = Contact Area
 μ = Coefficient of friction

The friction between the object and the picker is what allows the object to be held. Frictional force is equal to the load capacity of the picker. Increases in the pressure, contact area, or static coefficient of friction results in a greater load carrying capacity. This function leads to advantages as well as precautions with Firestone AirPicker® and AirGripper™ end-effectors.

Pressure

The amount of inflation pressure, and therefore the force exerted on the work piece, can be easily controlled with a regulator. This allows delicate objects to be handled with a compliant, yet secure, contact.

Contact Area

AirPicker® and AirGripper™ end-effectors utilize a greater contact area than typical mechanical finger pickers. This results in a higher load capacity than a comparable size picker with identical pressure. The effect that contact area has on the load capacity also helps explain the Firestone load curves.

As the diameter of an AirPicker® end-effector increases, the contact area between the rubber and object decreases. This is why the load curve slopes down with an increasing diameter at a constant pressure.

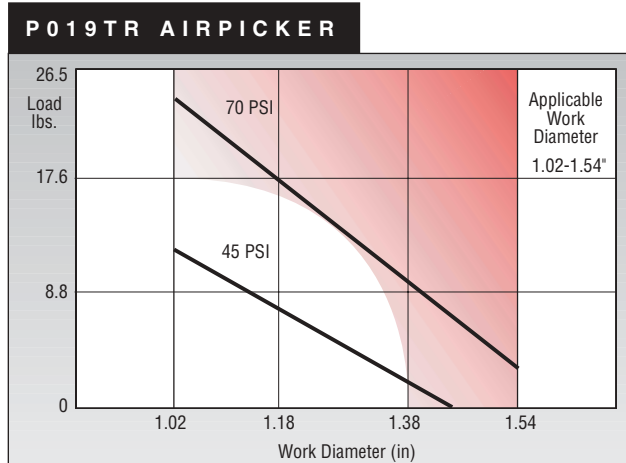

The ability to carry a greater load with a greater contact area is the basis for our high load capacity AirPicker® end-effectors (page 16). By multiplying the number of pickers, the contact area is equally multiplied.

The same load: contact-area relationship also applies to the AirGripper™ end-effector force curve. A larger diameter object will have a greater contact area with the inflated rubber bladder. This is why the load capacity increases with the size of the object being held.

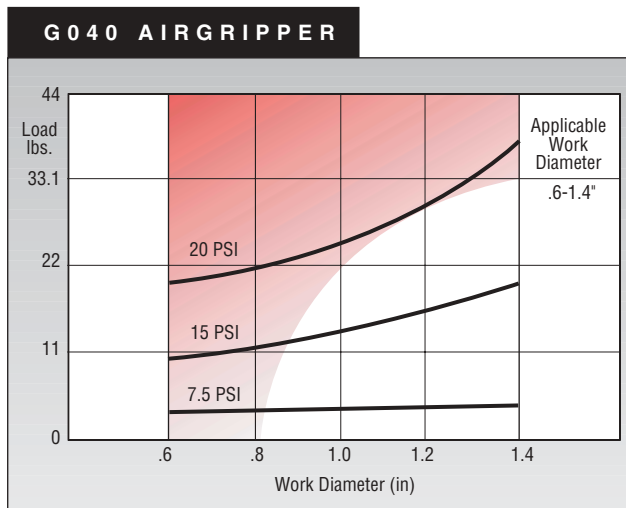

PERFORMANCE CHARACTERISTICS CONTINUED

Coefficient of Friction

The coefficient of friction between two materials is determined with empirical data. The greater the coefficient, the more gripping force the end-effector will have. For example, the static coefficient of a rubber tire on dry asphalt is 0.71. The static coefficient of friction drops to 0.17 – 0.06 on wet, slippery roads. After the rubber begins to slip at the contact point, the static coefficient becomes the sliding coefficient of friction. The sliding coefficient is a lower value than the static. For example, the sliding coefficient of a rubber tire on dry asphalt is approximately 0.65, compared to the 0.71 static coefficient.

The greater the coefficient of friction, the greater the load capacity of the picker. Therefore, it is best to handle dry objects. Wet, slippery surfaces will dramatically decrease load capacity. If the object begins to slip from the picker, the frictional force will continue to decrease. Our load curves are designed with a safety factor to compensate for various materials and coefficients. All of the load curves were generated using clean, dry, steel parts and have a safety factor of three. For example, our load carrying tests with a dry steel part indicate that the P025 can handle a 60lbs (27kg) object with 40psi (2.8bar). In order to compensate for a variety of application conditions, we have published a load carrying capacity of 20lbs (9kg) with 40psi (2.8bar). If you have any questions concerning extreme load capacities for a specific application, please call Firestone Industrial Products or your local distributor for assistance.

Life

Several factors affect the life of AirPicker[®] and AirGripper[™] end-effectors: inflation pressure, temperature, the object's shape/surface/weight, and the expansion ratio. Firestone has conducted a series of life tests to insure the quality of our products as well as to get a general idea of life expectancy. These tests do not guarantee that each application will achieve the same results in cycle life. The actual cycle life may exceed or fall short of the published figures due to changing variables.

AirGripper[™] end-effector Life

In a laboratory environment, neoprene AirGripper[™] end-effectors exceeded 1 million cycles at the maximum recommended pressure and diameter limits. Due to poor abrasion and tear resistance, the life of silicone AirGrippers dropped to approximately 100,000+ cycles at the maximum recommended parameters.

AirPicker[®] end-effector Life

Operating at the extreme pressure and diameter limits, neoprene AirPicker[®] end-effectors approached, and in some cases exceeded, 500,000 cycles. Less durable, yet high temperature tolerant, silicone AirPicker[®] end-effectors operated approximately 100,000 cycles at the maximum recommended parameters.

Expansion Ratio

The life of a picker will decrease as the ratio of inflated to deflated diameter increases. This change is described as the expansion ratio. In order to maximize the life of a picker, it is recommended that pickers be used within the suggested diameter range, preferably near the midpoint.

Surface Finish

The surface finish of the work piece is another critical variable in affecting the life of a picker. The smoother the finish, the longer the life.

Cycle Rate

High cycle rate applications do not have an adverse effect on the total cycle life of a Firestone end-effector.

Temperature

The temperature of the work piece is crucial to the life of a picker. For temperatures exceeding 165°F (74°C), silicone elastomer is recommended. Silicone can perform at elevated temperatures, -22°F to 320°F (-30°C to 160°C), but has poor abrasion resistance. However, neoprene will become brittle at elevated temperatures, making it inoperable.

PERFORMANCE CHARACTERISTICS CONTINUED

Diameter vs Pressure

The diameter of a Firestone end-effector is a function of applied pressure, as well as the construction of the rubber bladder. This is a critical variable when holding very light objects. In order to maximize the life of the part, it is best to use the lowest inflation pressure possible, just enough to reach the desired diameter and grasp the part. The nature of the rubber bladder will also control the diameter. More pressure is required to reach a given diameter with fabric reinforced rubber bladders or when protective sleeves are used.

Cycle Rate

Cycle rate, or the minimum cycle time, is limited by a few factors. The pressure of the air source and the flow resistance in the plumbing will restrict inflation. The flow resistance in the plumbing, as well as the shrinking force of the rubber bladder, affects deflation. Because of this, the cycle rate largely depends upon the air system. Without operating at extreme conditions, life cycle testing was completed with a cycle rate of 30 cycles per minute. In general, small AirPicker® end-effectors have a short complete cycle time. As an end-effector gets larger, the cycle rate is slowed due to the larger volume of air being moved.

Body Tolerances

AirPicker® and AirGripper™ end-effector bodies are machined with medium class tolerances. The following table gives corresponding tolerances for a dimension range. Finer class tolerances are available for special orders.

Dimensions (in/mm)		Tolerance (in/mm)	
0.0 - 0.1	0.5 - 3	± 0.004	± 0.1
0.1 - 0.2	3 - 6	± 0.004	± 0.1
0.2 - 1.2	6 - 30	± 0.008	± 0.2
1.2 - 4.7	30 - 120	± 0.012	± 0.3
4.7 - 12.4	120 - 315	± 0.020	± 0.5
12.4 - 39.4	315 - 1000	± 0.031	± 0.8
39.4 - 78.7	1000 - 2000	± 0.004	± 0.1

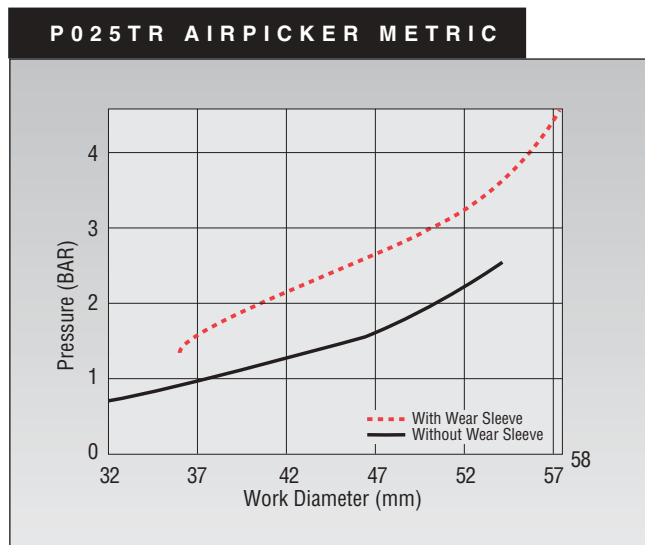
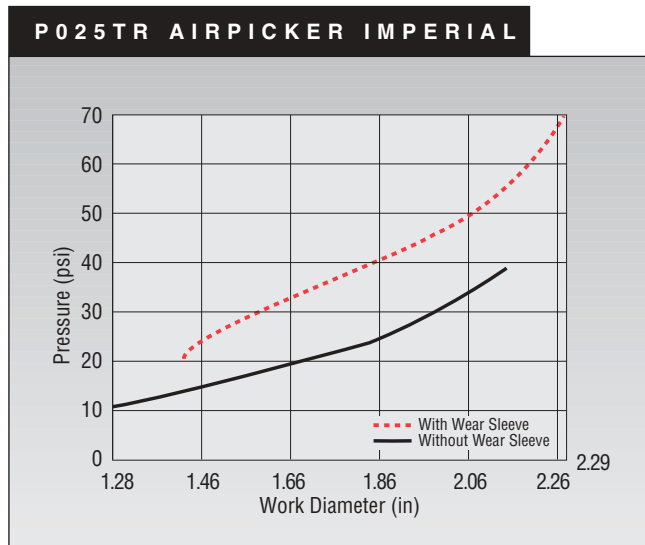

PERFORMANCE CHARACTERISTICS CONTINUED

Repeatability

As shown on the following chart for the P010 AirPicker[®] end-effectors, diameters of the AirPicker[®] and AirGripper[™] end-effectors are not constant over time. AirPicker[®] and AirGripper[™] end-effectors will consistently operate and hold objects within the recommended working diameter range. However, due to the elastic properties of rubber, the unrestricted diameter of the end-effectors cannot be precisely controlled.

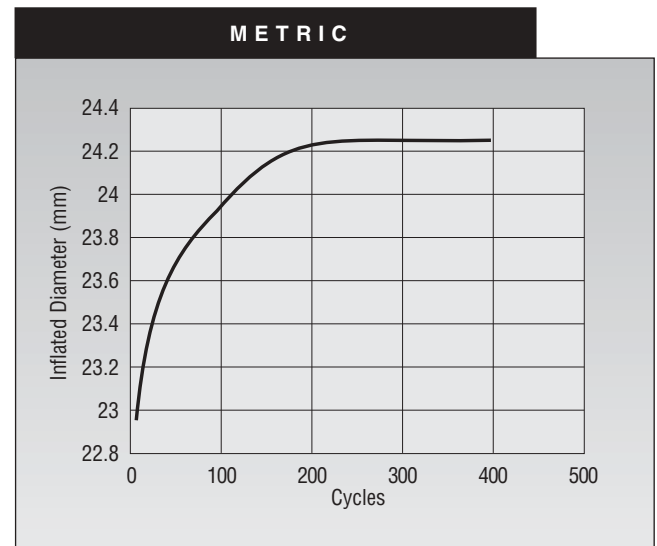
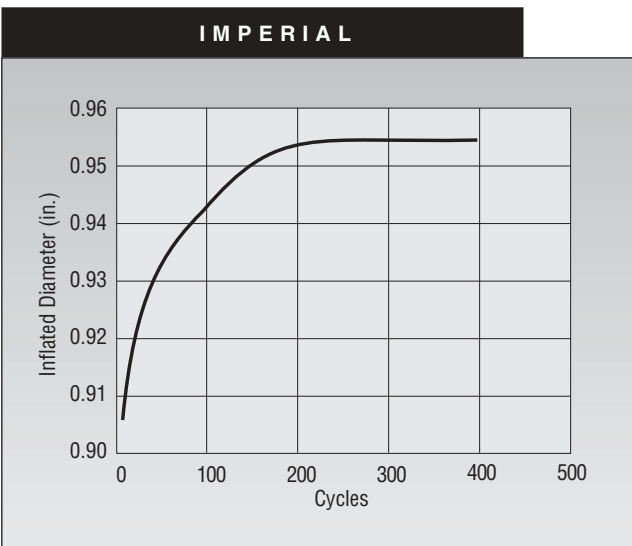

Centering and Positioning

Firestone end-effectors are designed to handle a wide variety of shapes and delicate objects. Extremely precise centering and positioning is not possible due to the compliant nature of the rubber and air. The fabric reinforcement of AirPicker[®] end-effectors controls the shape of the bladder during inflation and provides a symmetrical end-effector. The standard AirGripper[™] end-effector, however, is an all-rubber construction that provides a wide diameter range, but is not a good centering device.

Rotational Displacement

The rubber bladder of an AirPicker[®] end-effector can rotate slightly, approximately 2 degrees, around the body. This will not affect most applications, but should be noted. If an application requires rotational precision, Firestone offers a low displacement AirPicker[®] end-effector as shown in the Miscellaneous Construction section of this design guide (page 16).

C O N S T R U C T I O N

AIRPICKER®
 E N D - E F F E C T O R

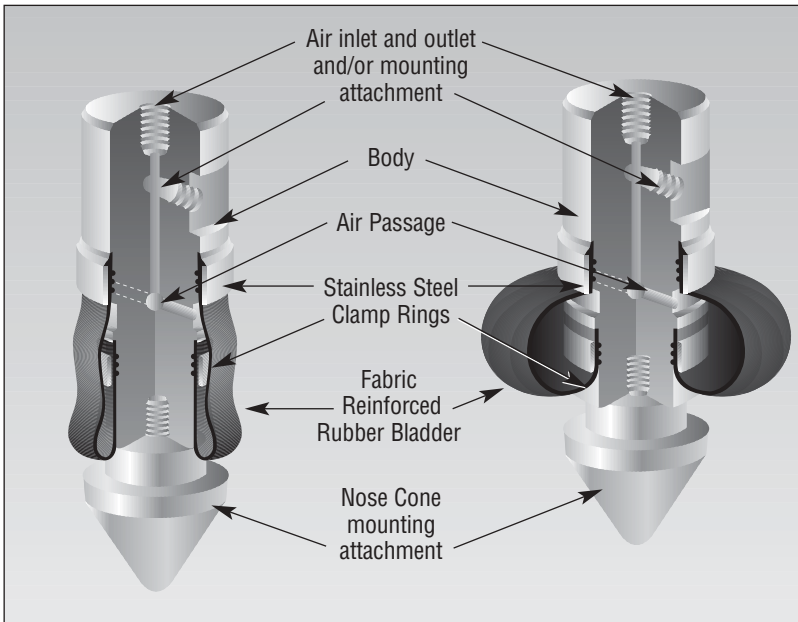

An AirPicker® end-effector consists of a fabric reinforced rubber bladder swaged onto a metal body with two stainless steel clamp rings. The body of the picker runs the length of the part and is machined stainless steel, plated steel, or aluminum, depending upon its size. An air passage is drilled through the center of the body and tees off into the inflatable bladder area. Mounting holes or threads are also machined into the body. The type of mounting depends upon the size of the end-effector. A threaded hole is also machined into the body for mounting a nose cone.

AIRGRIPPER™
 E N D - E F F E C T O R

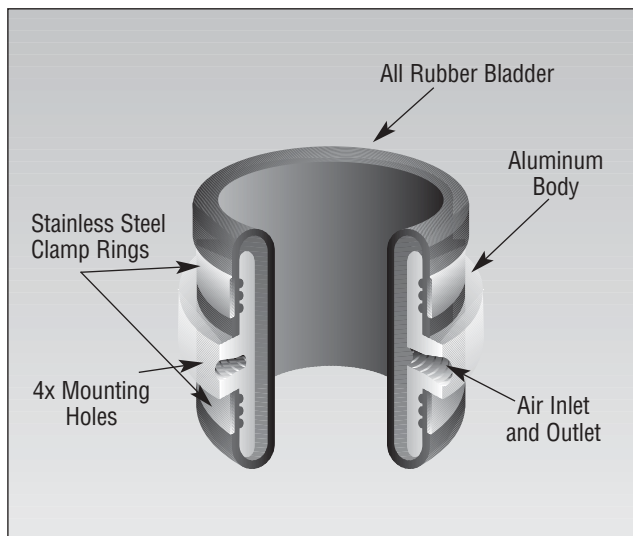

Standard AirGripper™ end-effector construction consists of an all rubber bladder swaged onto an aluminum body with two stainless steel clamp rings. The aluminum body has 4 mounting holes drilled and tapped along the outside diameter with a single air passage.

CONSTRUCTION CONTINUED

Body

Stainless Steel P006 - P009

Due to the small size of AirPicker® end-effectors, the corrosion resistance and strength of stainless steel are available without adding a significant amount of weight. The P006 –P009 sizes have a single air passage at the top with a threaded body for mounting.

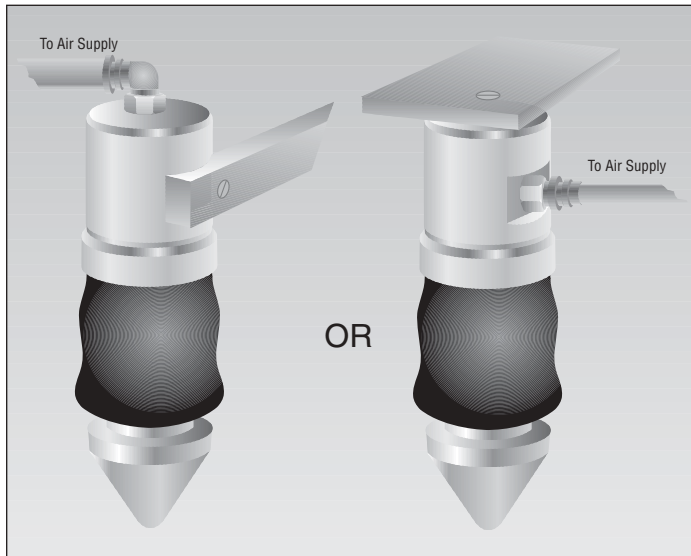
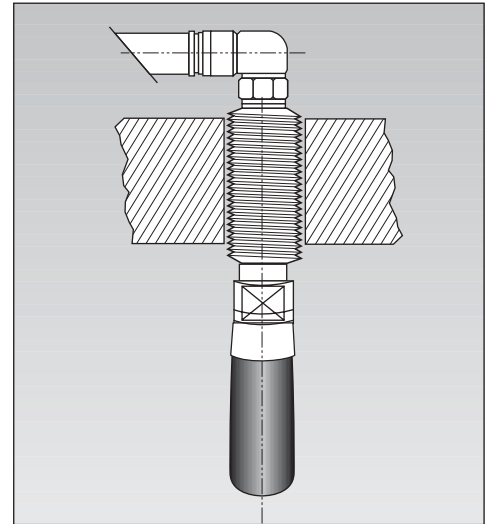

Steel (Plated) P010 - P025

Plated steel is an inexpensive and durable material for the mid-range size picker end-effectors. The P010 – P025 have two tapped holes, one for the air fitting, the other as a mounting attachment. The hole that is not used for the air passage must be plugged to prevent air loss.

Aluminum P035 - P055

Strong, lightweight aluminum is used for the larger AirPicker® end-effector (P035 – P055). The P035 has identical mounting and air passage design as the smaller P010-P025. The P045 and P055 also have two tapped holes, along with three equally spaced mounting holes on top to handle their greater load capacities.

Aluminum G020 - G050

G020 – G050 AirGripper™ end-effectors all have identical mounting configurations. Each aluminum body has four equally spaced mounting holes drilled and tapped along the outside diameter. One air passage is also provided as the inlet/outlet.

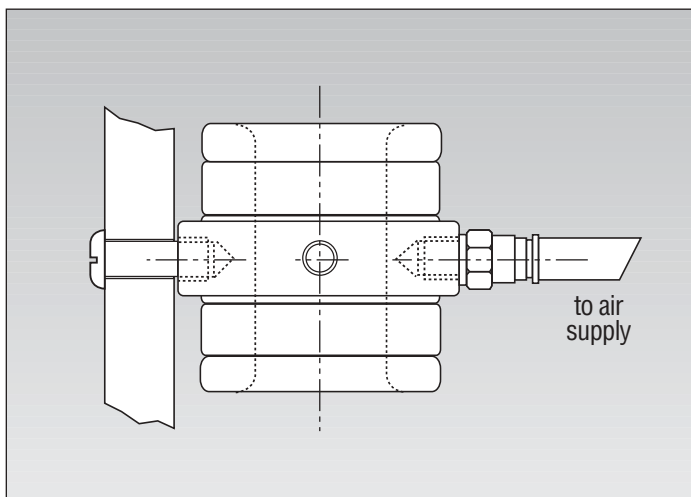

CONSTRUCTION CONTINUED

Rubber Bladder Material

AirPicker® and AirGripper™ end-effectors use a combination of different elastomers and fabric reinforcement to provide the best possible end-effector for specific applications.

Neoprene

Neoprene is the standard rubber material for pickers and grippers. The following chart lists its characteristics.

Resilience - Rebound	Excellent
Abrasion Resistance	Excellent
Tear Resistance	Good
Solvent Resistance	Fair
Oil Resistance	Fair
Temperature Range	0° to 165° F, -18° to 74°C

Silicone

Silicone is recommended only in high temperature applications. This material sacrifices significant life due to poor abrasion and tear resistance, but operates in an extremely wide temperature range.

Resilience - Rebound	Fair
Abrasion Resistance	Fair to Poor
Tear Resistance	Poor
Solvent Resistance	Poor
Oil Resistance	Fair to Poor
Temperature Range	-22° to 320° F, -30° to 160°C

Fabric Reinforcement

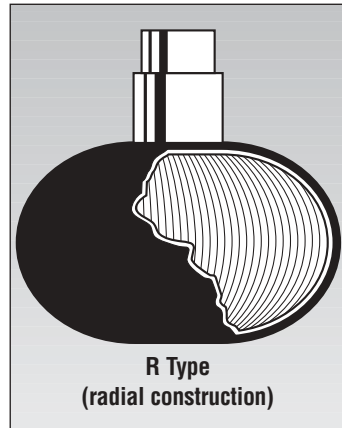

Radial Fabric Reinforcement (P006 – P025)

Radial fabric increases pressure capabilities of end effectors to 55psig for the P006-P009 and 70psig (5bar) for the P010-P055, while allowing a wide working diameter range.

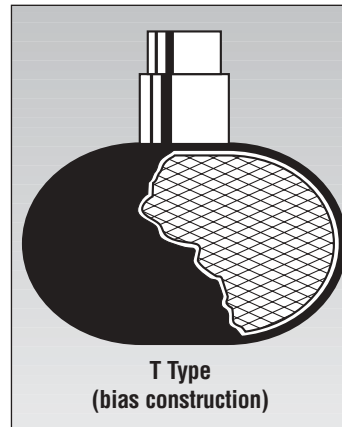

Bias Fabric Reinforcement (P035 – P055)

Bias fabric reinforcement provides the strongest bladder in terms of burst pressure, but sacrifices the working diameter range. Larger sizes require this type of reinforcement since the exposed surface area of the rubber is greater.

All Rubber Construction (G020 – G050)

All rubber construction allows for the greatest diameter range, but sacrifices the maximum working pressure. All rubber construction is used on the standard AirGripper™ end-effector to provide the maximum working diameter range.

MISCELLANEOUS CONSTRUCTION & MODELS

Miscellaneous Construction & Models

Firestone offers special order AirPicker[®] and AirGripper[™] end-effectors for applications with requirements beyond the capabilities of our standard products. The price and availability of these models are strictly dependent upon production quantities.

High Load Capacity AirPicker[®] end-effector

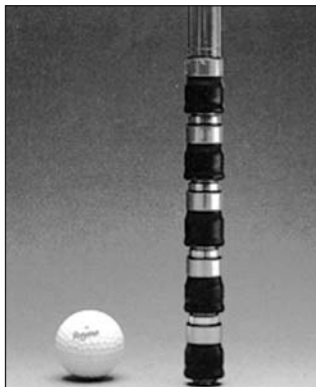

In order to carry a greater load, Firestone offers AirPicker[®] end-effectors stacked upon each other, thereby multiplying the contact surface area. By multiplying the surface area, the load carrying capacity is equally multiplied.

Low Rotational Displacement AirPicker[®]



When an AirPicker end-effector is inflated, the rubber will rotate slightly. This minimal rotational displacement is discussed in greater detail in the Performance Characteristics section. In order to eliminate this displacement, Firestone offers a construction with two attached AirPicker[®] end-effectors facing opposite directions. The rotational displacements of the two pickers are in opposite directions, thereby nullifying the end result on the work piece.

Fabric Reinforced AirGripper[™] end-effector

Our standard AirGripper[™] end-effector uses an all rubber bladder to provide the maximum working diameter range possible. As discussed previously, this construction results in a low recommended working pressure of 20 psig (1.5bar). For applications requiring greater load carrying and pressure capability, a fabric reinforced AirGripper[®] end-effector is available. These AirGripper[™] end-effectors can handle pressures up to 70 psig (5bar), but the working diameter range is sacrificed.

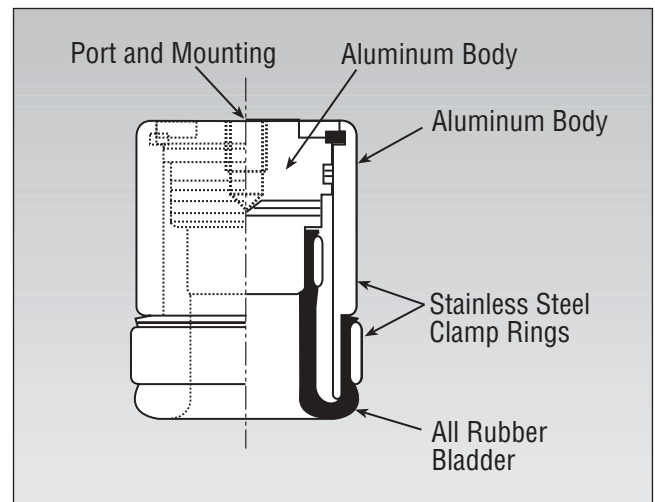

Gripping

The Gripping is similar to the AirGripper[™] end-effector with a modified mounting and clamping arrangement. This construction is common in bottling applications and where top mounting is preferred or radial space is limited.

Alternative Rubber Material

Some applications require different temperature ranges or chemical compatibility. Consult Firestone for further information.

MISCELLANEOUS CONSTRUCTION & MODELS CONTINUED

Low Profile AirGripper™ end-effector

If the standard AirGripper™ end-effector does not fit into the design envelope of an application, Firestone offers low profile grippers. These grippers are about 2/3 the height of our standard grippers. Since the length of the rubber is decreased, the working diameter range is also reduced.

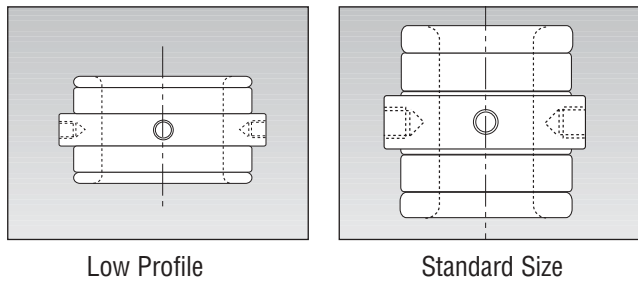

Low Profile

Standard Size

Large AirPicker® & AirGripper™ end-effectors

The maximum working diameter of the standard P055 and G050 end effectors is 4.1 inches (105mm) and 1.8 inches (45mm) respectively. We have accommodated

applications that require inflated outside diameters as great as 12.6 inches (320mm) with our AirPicker® end-effectors, and uninflated diameters as large as 5.6 inches (142mm) for the AirGripper™ end-effector. The following chart shows the diameter capabilities of our non-standard large AirPicker® and AirGripper™ end-effectors. Please contact Firestone if a specific application requires the benefits of larger AirPicker® or AirGripper™ end-effectors.

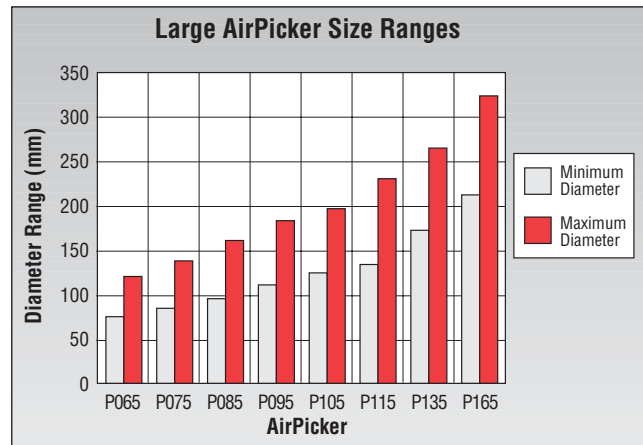
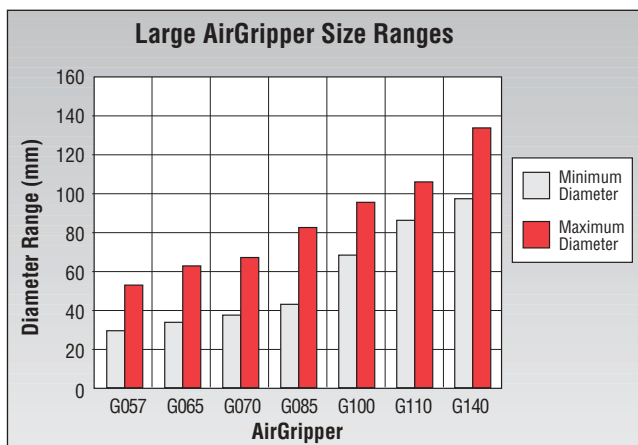
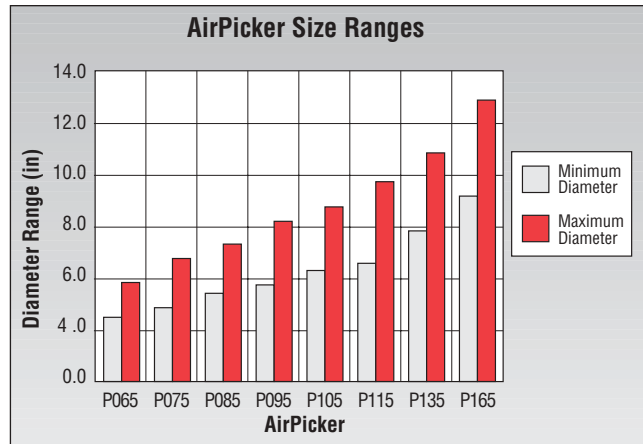
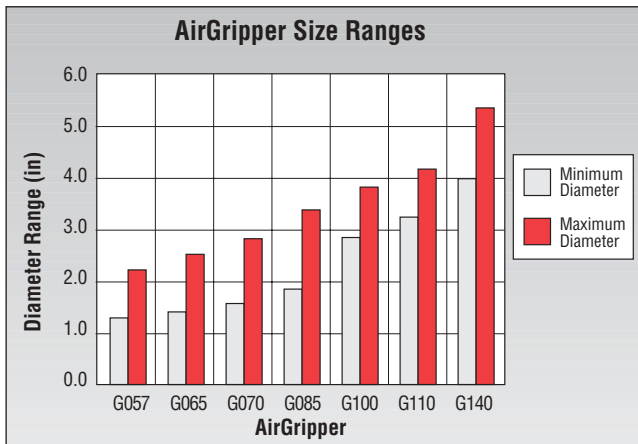

ACCESSORIES

Nose Cones

In order to center an AirPicker® end-effector and protect the rubber from abrasion during insertion, Firestone offers nose cones. These nose cones are easily screwed into the metal body.

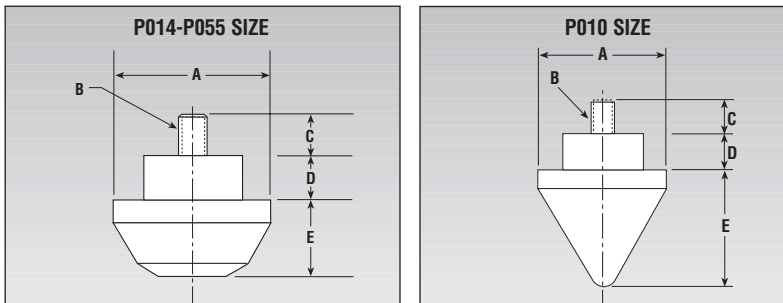

APPLICABLE AIRPICKER	NOSE CONE PART NUMBER (WP1-358-0000)	A (IN/MM)	B THREAD	C (IN/MM)	D (IN/MM)	E (IN/MM)
P010	1006	0.58/14.7	8-32	0.22/5.6	0.19/4.8	0.50/12.7
P014	1016	0.78/19.8	10-24	0.25/6.4	0.31/7.9	0.55/14.0
P017	1017	0.90/22.9	10-24	0.25/6.4	0.31/7.9	0.55/14.0
P019	1018	1.10/27.9	10-24	0.25/6.4	0.31/7.9	0.55/14.0
P022	1019	1.13/28.7	10-24	0.29/7.4	0.31/7.9	0.55/14.0
P025	1020	1.17/29.7	1/4-20	0.29/7.4	0.31/7.9	0.55/14.0
P035	1021	1.68/42.7	1/4-20	0.29/7.4	0.31/7.9	0.68/17.3
P045	1022	2.03/51.6	1/4-20	0.29/7.4	0.31/7.9	0.68/17.3
P055	1023	2.51/63.8	1/4-20	0.29/7.4	0.31/7.9	0.68/17.3

Rebuild Program

Firestone end-effectors are repairable. In cases where the rubber bladder is no longer in working condition, a new bladder can be swaged onto the existing body. The AirPicker® or AirGripper™ end-effector must be returned to Firestone with a proper return goods number for the process to be completed. Please contact your local Firestone Industrial distributor for details concerning this program.

Metric Air Fittings and Plugs

The air fittings and threads for mounting purposes on the metric (WP1-M58-) parts are unified (straight) threads. The air fittings connect to 1/8 inch OD tube. The sizes are as follows:

Designation	Thread	Air Fitting	Plug
M3	M3 x 0.5 mm	WP1-M58-1001	N/A
M5	M5 x 0.8 mm	WP1-M58-1004	WP1-M58-1002
M6	M6 x 1.0 mm	WP1-M58-1003	WP1-M58-1006
PT 1/8	Tapered Thread	WP1-M58-1005	N / A

Protective Sleeves

In order to protect the rubber bladder from abrasive surfaces, Firestone offers neoprene protective sleeves.

APPLICABLE AIRPICKER	SLEEVE PART PART NUMBER (WP1-358-0000)	T (IN/MM)	D (IN/MM)	L (IN/MM)
P014	1500	0.05/1.3	0.7/18	1.5/38
P017	1501	0.05/1.3	0.8/20	1.5/38
P019	1502	0.05/1.3	0.9/23	1.5/38
P022	1503	0.05/1.3	1.0/25	1.75/44
P025	1504	0.08/2.1	1.1/27	2.125/54
P035	1505	0.08/2.1	1.5/37	2.5/64
P045	1506	0.08/2.1	1.9/47	2.875/73
P055	1507	0.08/2.1	2.2/57	3.125/79

A rubber sleeve is slipped over the deflated bladder with the assistance of air or water as a lubricant. In addition to improving the life in a standard application, the protective sleeve can also provide the needed support when inflating the AirPicker® end-effector unrestrained.

The thickness of the protective sleeve will increase the diameter of the rubber bladder as well as restrict its diameter growth during inflation. The effect the sleeve has on the diameter is shown on the individual data page.

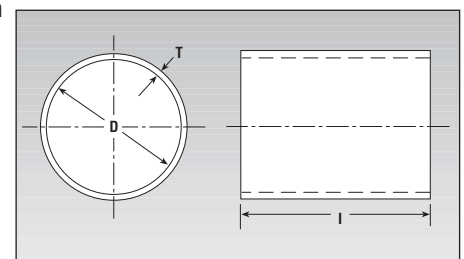

SELECTION PROCEDURE

There are three main parameters needed to select the correct end-effector for a standard application.

- Inside or outside diameter of the work piece (depending where the work piece will be gripped)
- Depth of the contact area
- Load of the work piece

Other factors must be taken into consideration to determine if a Firestone AirPicker® or AirGripper™ end-effector is suitable for a specific application.

- Texture of the contact surface
- Temperature of the environment
- Chemical compatibility
- Mounting surface dimensions
- Design envelope

These other factors will play a role as individual applications arise, but the basic design procedure depends upon the dimensions and load of the object to be handled. The typical selection procedure is as follows:

1. Using the Selection Guide on page 22, select the correct AirPicker® or AirGripper™ end-effector which inflates to the correct diameter of the object. Select the AirPicker® or AirGripper™ that will expand the least to fit the diameter of the object.

2. Determine if the depth of the contact surface is at least equivalent to the length of the rubber bladder. If this is not the case, the load capacity will be reduced and the end-effector may squeeze out the work piece.
3. Maximum load capacities in the working diameter range of the end-effectors are shown on the Selection Guide. The load capacities will vary depending upon the available air pressure, contact area, and coefficient of friction. This portion of the table is given to provide a general idea of load capacities. If the application falls within the shaded portion of the graph, premature wear may occur to the AirPicker® or AirGripper™ that may lead to shorter cycle life.
4. After a selection has been made, refer to the individual data page given on the Selection Guide. This page will provide detailed information concerning load capacities, dimensions, inflated diameter, assembly number, etc.
5. Determine exact inflation pressure required for the specific application from the Diameter vs Pressure Curve for lightweight loads, or the Load vs Diameter Curve for heavier loads.

Determining Required Pressure for Heavy Loads

If the object's weight is in the range shown on the Load vs Diameter Curve, refer to those tools to determine the exact pressure required for the application.

Diameter vs Load Curve

1. Draw a horizontal line intersecting the required load on the vertical axis.

2. Draw a vertical line intersecting the required work diameter of the object on the horizontal axis.
3. The intersection point of these two lines should be near one of the constant pressure curves on the chart. A rough estimate of the required pressure can be made in relation to the nearby constant pressure curves.

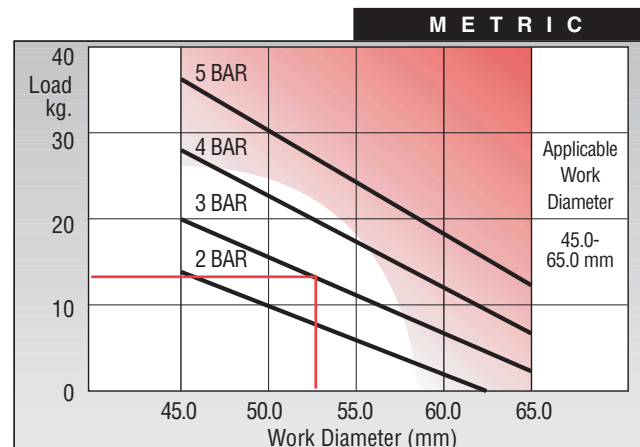
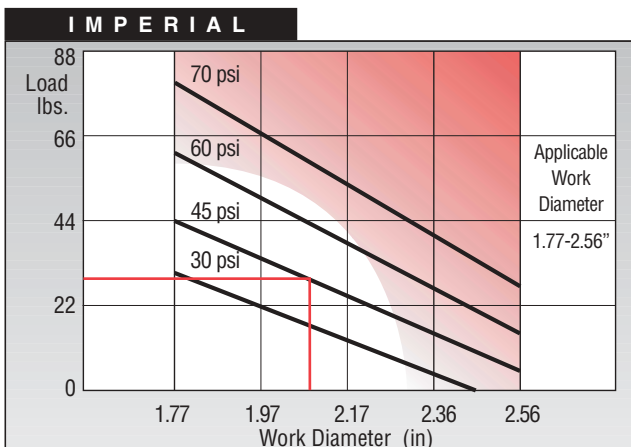

The P035 requires 45 psig (3 bar) in order to hold 28 lbs (13 kg) at a 2.1 inch (53 mm) diameter.

SELECTION PROCEDURE CONTINUED

An identical procedure is used to determine the required pressure with an AirGripper™ end-effector.

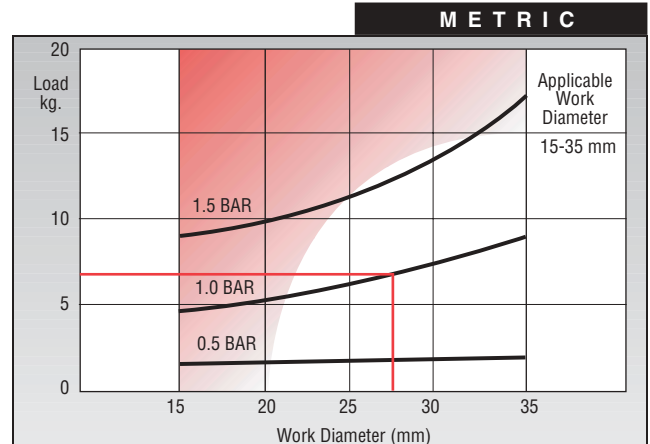
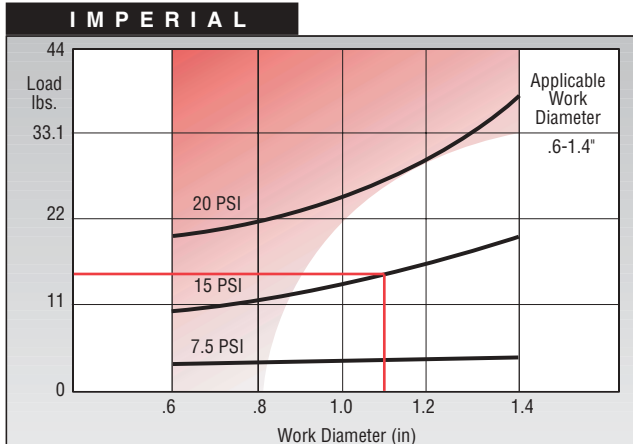

The G040 requires 15 psig (1.0 bar) in order to hold 14 lbs (6.5 kg) at a 1.1 inch (28 mm) diameter.

Determining Required Pressure for Light Loads

If the object's weight is lighter than the loads shown on the Load vs Diameter Curve and Table, refer to the Diameter vs Pressure data to determine the minimum amount of pressure required for the application.

1. Refer to the Diameter vs Pressure Curve for the specific AirPicker® or AirGripper™ end-effector.
2. Move vertically from the inflated diameter required to hold onto the object until the vertical line intersects the data curve.
3. Proceed horizontally to the left from this point until the pressure axis is intersected.
4. The intersected pressure is the amount required to grip the object.

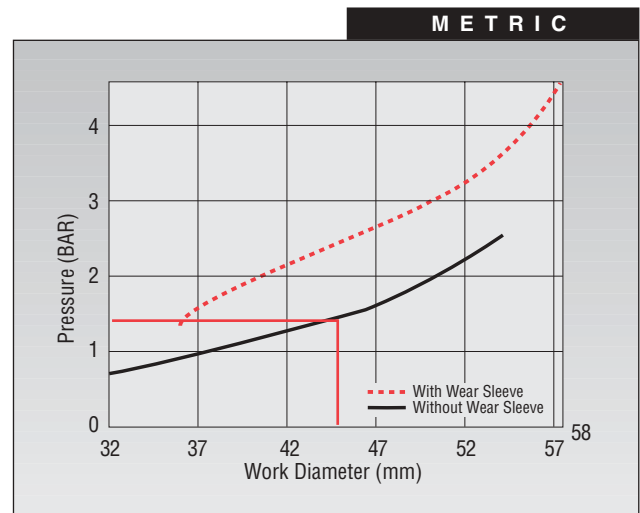
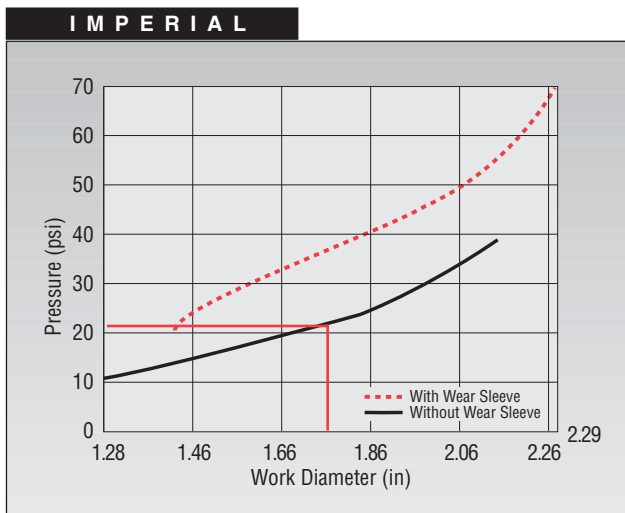

The P025 requires 21 psig (1.4 bar) in order to reach a diameter of 1.75 inches (45 mm) without a wear sleeve after proper preconditioning.

APPLICATIONS



Handling & packaging bottles

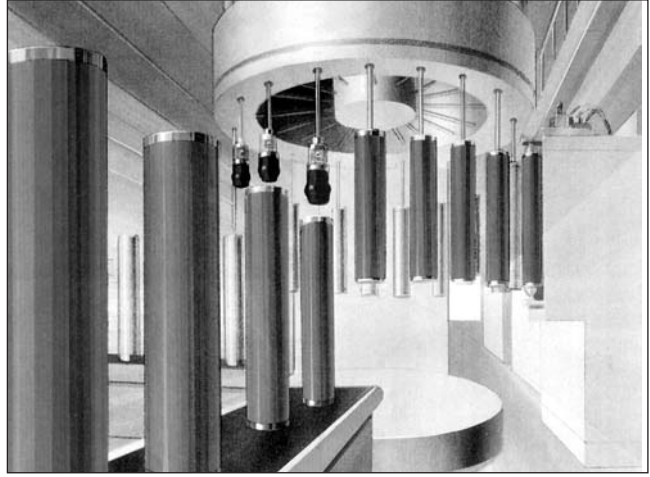

Handling photosensitive copier drums

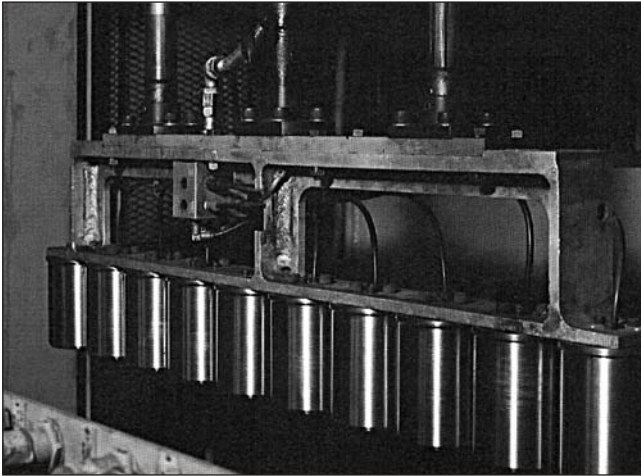

Lifting cylinder liners for engines

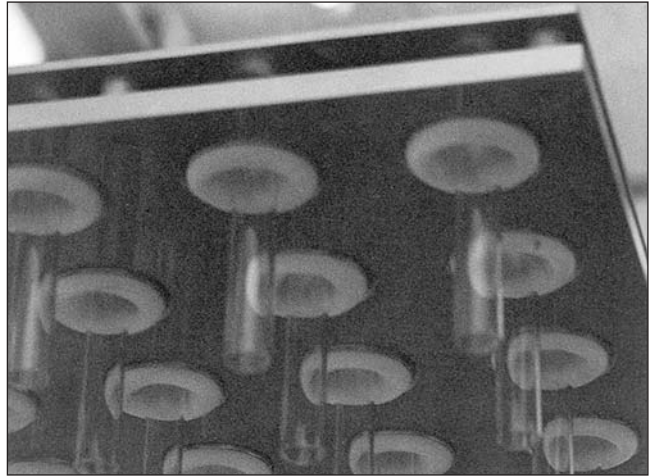

Transferring hot, freshly molded test tubes



Gripping and carrying inverted TV tubes

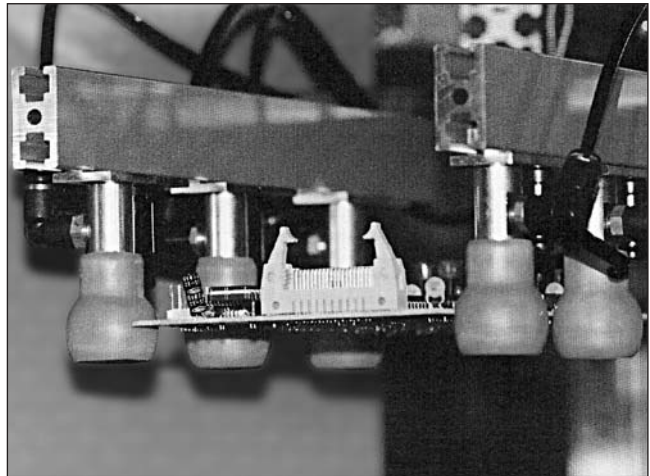

Gripping IC boards

SELECTION GUIDE & INDEX

AirPicker[®] end-effector - Neoprene Rubber Material

Style Number	Rubber Bladder Length (inches / mm)	Deflated Diameter (inches / mm)	Maximum Restricted Pressure Allowed (psig / bar)	Working Diameter Range (inches / mm)	Load Capability in Working Diameter Range at Max. Allowed Pressure (lbs / kg)	AirPicker or AirGripper Weight (oz / g)
P006RCA	0.65 / 17	0.31 / 8	55 / 4	0.33-0.39 / 8.5-10	3.3-0.3 / 1.5-0.15	0.5 / 8
P007RCA	0.65 / 17	0.37 / 9	55 / 4	0.39-0.51 / 10-13	3.4-0.5 / 1.5-0.23	0.5 / 12
P009RCA	0.65 / 17	0.43 / 11	55 / 4	0.47-0.69 / 12-17	6.6-2.5 / 3.0-1.1	0.5 / 17
P010RCA	0.79 / 21	0.55 / 14	70 / 5	0.63-0.83 / 16-18	* 6.6-4.4 / 3.0-2.0	1.0 / 28
P014RCA	0.87 / 22	0.75 / 19	70 / 5	0.79-1.06 / 20-27	16.3-6.6 / 7.4-3.0	2.0 / 60
P017RCA	0.87 / 22	0.87 / 22	70 / 5	0.91-1.26 / 23-32	23.0-7.7 / 10.4-3.5	3.0 / 85
P019RCA	0.87 / 22	0.98 / 25	70 / 5	1.02-1.54 / 26-40	* 25.0-4.0 / 11.3-1.8	3.5 / 105
P022RCA	1.10 / 28	1.10 / 28	70 / 5	1.18-1.73 / 30-44	30.0-15.0 / 13.6-6.8	5.5 / 160
P025RCA	1.34 / 34	1.14 / 29	70 / 5	1.26-2.13 / 32-54	55.0-20.0 / 24.9-9.1	8.5 / 245
P035TCA	1.65 / 42	1.65 / 42	70 / 5	1.77-2.56 / 45-65	77.0-25.0 / 34.9-11.3	6.0 / 180
P045TCA	2.09 / 52	2.00 / 51	70 / 5	2.28-3.35 / 58-85	130.0-50.0 / 59.0-22.7	13.0 / 370
P055TCA	2.09 / 53	2.48 / 63	70 / 5	2.76-4.13 / 70-105	160.0-66.0 / 72.6-29.9	21.5 / 610

* The Load Capability of the P010 and P019 are given at 40psig (3bar) and 55psig (4bar) respectively

AirPicker[®] end-effector - Silicone Rubber Material

P014RCAS	0.87 / 22	0.79 / 20	25 / 1.8	0.83-1.00 / 22-25	2.2-0.5 / 1.0-0.23	2.0 / 60
P017RCAS	0.87 / 22	0.91 / 23	25 / 1.8	1.00-1.18 / 25-30	3.3-0.4 / 1.5-0.50	3.0 / 85
P019RCAS	0.91 / 23	1.06 / 27	25 / 1.8	1.18-1.40 / 30-35	2.3-1.1 / 1.0-0.50	4.0 / 110
P022RCAS	1.14 / 29	1.14 / 29	25 / 1.8	1.26-1.58 / 32-40	5.5-1.3 / 2.5-0.60	6.0 / 165
P025RCAS	1.26 / 32	1.22 / 31	25 / 1.8	1.34-1.66 / 34-42	7.7-2.3 / 3.5-1.0	4.0 / 110
P035RCAS	1.50 / 38	1.65 / 42	25 / 1.8	1.81-2.27 / 46-58	8.0-4.5 / 3.6-2.0	6.0 / 180

AirGripper[™] end-effector - Neoprene Rubber Material

G020GCA	1.50 / 38	0.70 / 18	20 / 1.5	0.20-0.60 / 5-15	4.0-11.0 / 1.8-5.0	2.0 / 60
G030GCA	2.00 / 51	1.10 / 28	20 / 1.5	0.40-1.00 / 10-25	9.0-27.0 / 4.1-12.3	5.0 / 145
G040GCA	2.10 / 53	1.50 / 38	20 / 1.5	0.60-1.40 / 15-35	20.0-36.0 / 9.1-16.3	7.5 / 210
G050GCA	2.20 / 56	1.90 / 28	20 / 1.5	0.80-1.80 / 20-45	20.0-50.0 / 9.1-22.7	10.0 / 285

AirGripper[™] end-effector - Silicone Rubber Material

G020GCAS	1.50 / 38	0.70 / 18	15 / 1	0.20-0.60 / 5-15	3.0-8.3 / 1.4-3.8	2.0 / 60
G030GCAS	2.00 / 51	1.10 / 28	15 / 1	0.40-1.00 / 10-25	6.8-20.3 / 3.0-9.2	4.5 / 130
G040GCAS	2.10 / 53	1.50 / 38	15 / 1	0.60-1.40 / 15-35	15.0-27.0 / 6.8-12.2	7.5 / 210
G050GCAS	2.20 / 56	1.90 / 28	15 / 1	0.80-1.80 / 20-45	15.0-37.5 / 6.8-17.0	9.0 / 260

Assembly Order No.	Rubber Material	F1	F2	F3	Clamp Ring	Body Material	Max Restricted Pressure (psig/bar)	Max Unrestricted Pressure (psig/bar)
WP1-M58-0001	Neoprene	M6	M3	N/A	Stainless Steel	Stainless Steel	55 / 4	25 / 1.8

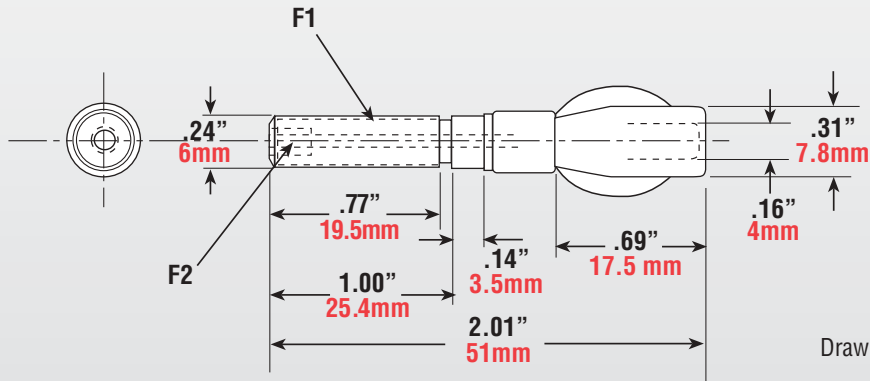

IMPERIAL

METRIC

FORCE CURVES

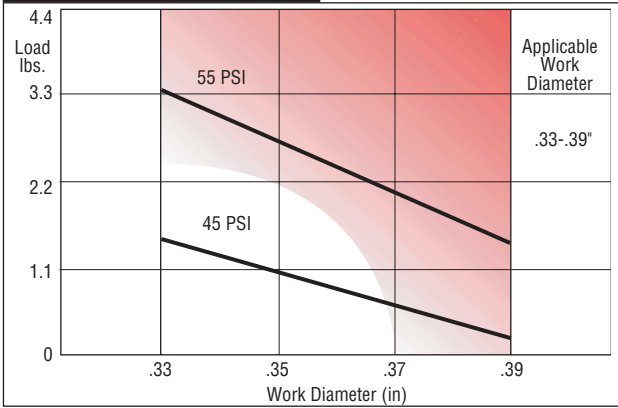

FORCE CURVES

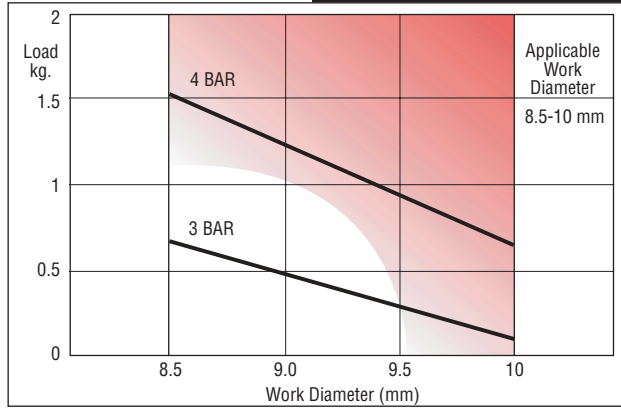

PRESSURE VS INFLATED DIAMETER

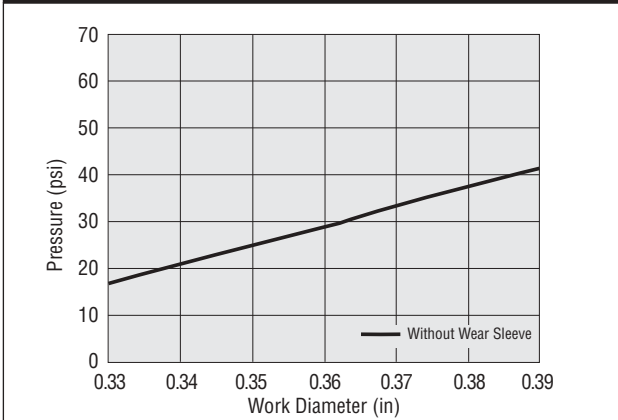

PRESSURE VS INFLATED DIAMETER

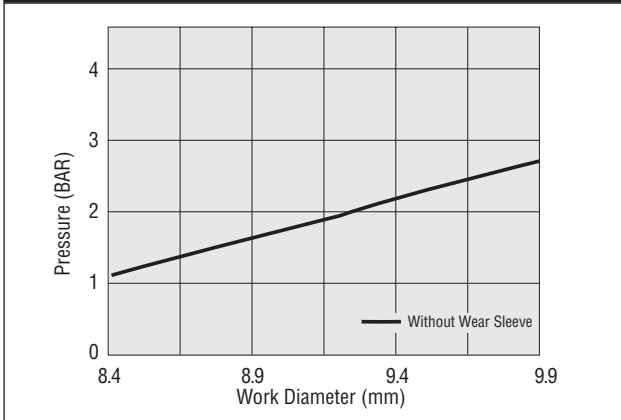

Assembly Order No.	Rubber Material	F1	F2	F3	Clamp Ring	Body Material	Max Restricted Pressure (psig/bar)	Max Unrestricted Pressure (psig/bar)
WP1-M58-0002	Neoprene	M6	M3	N/A	Stainless Steel	Stainless Steel	55 / 4	25 / 1.8

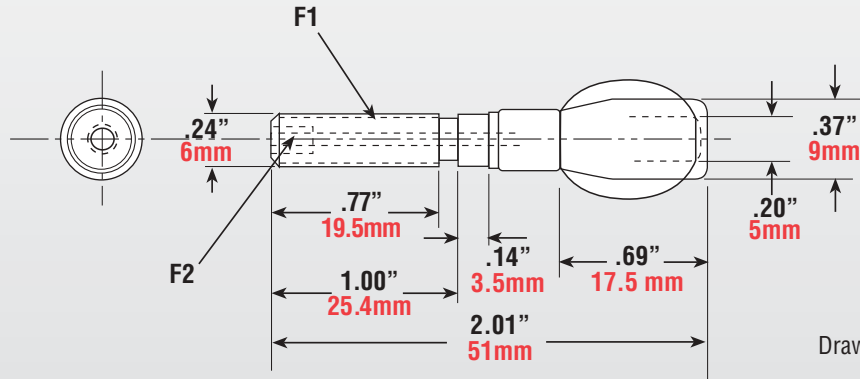

IMPERIAL

FORCE CURVES

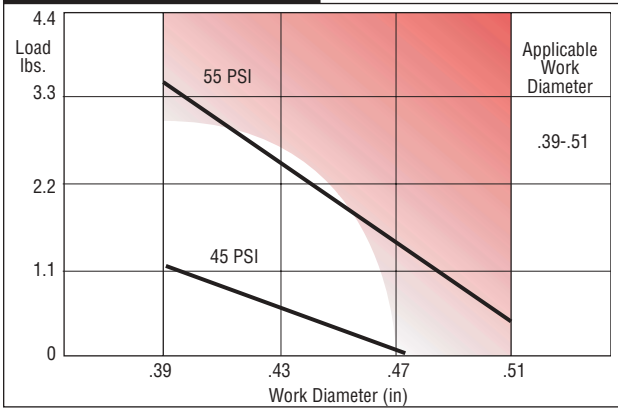

PRESSURE VS INFLATED DIAMETER

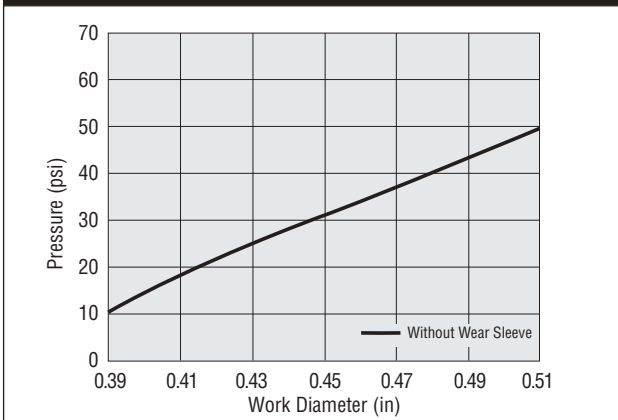

METRIC

FORCE CURVES

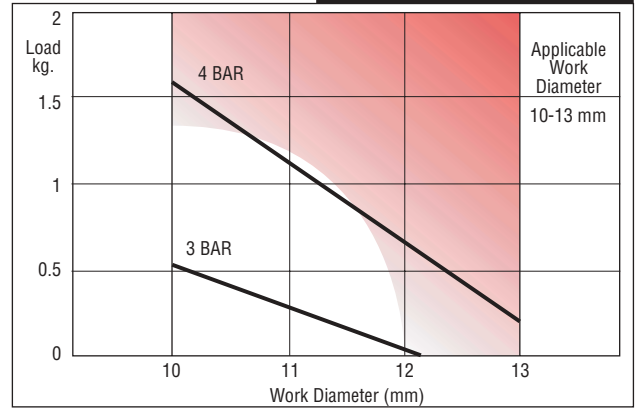

PRESSURE VS INFLATED DIAMETER

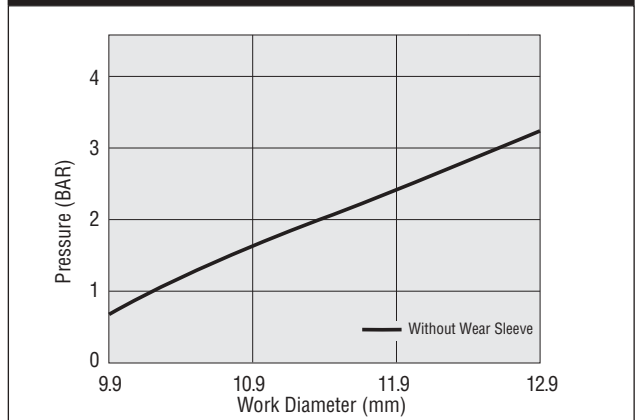

Assembly Order No.	Rubber Material	F1	F2	F3	Clamp Ring	Body Material	Max Restricted Pressure (psig/bar)	Max Unrestricted Pressure (psig/bar)
WP1-M58-0003	Neoprene	M8	M5	N/A	Stainless Steel	Stainless Steel	55 / 4	25 / 1.8

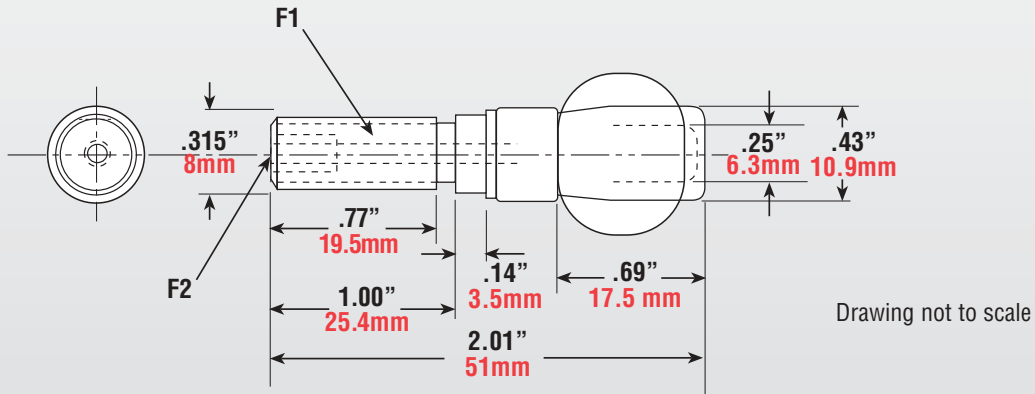

IMPERIAL

METRIC

FORCE CURVES

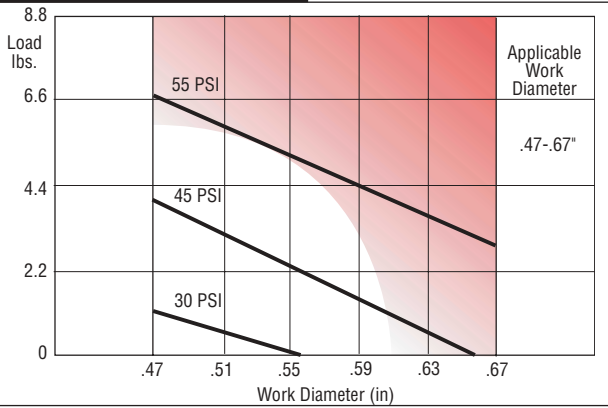

FORCE CURVES

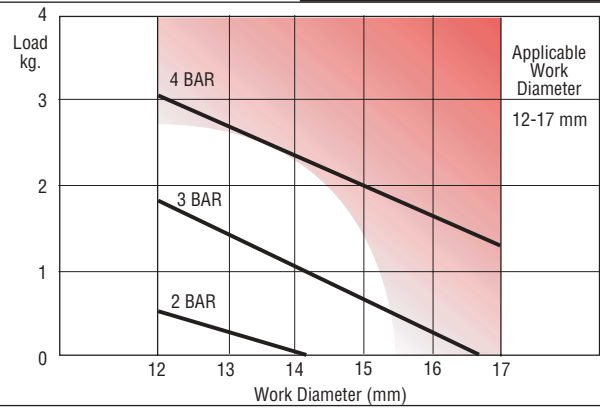

PRESSURE VS INFLATED DIAMETER

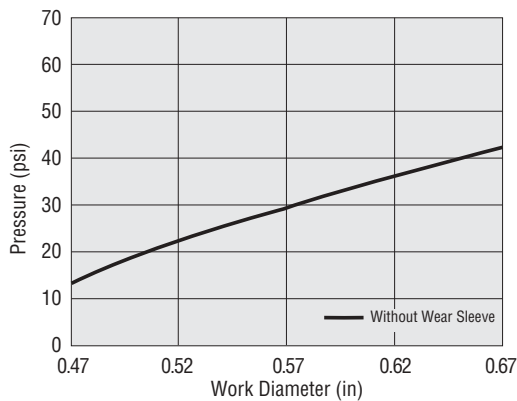

PRESSURE VS INFLATED DIAMETER

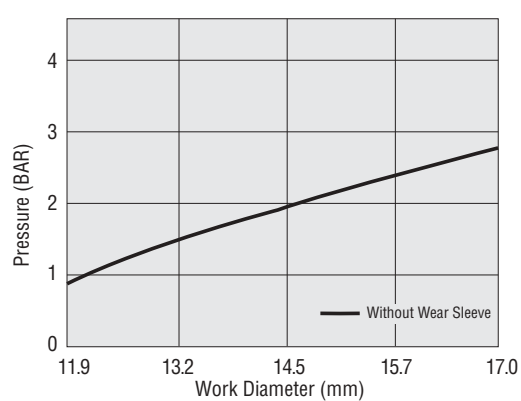

Assembly Order No.	Rubber Material	F1	F2	F3	Clamp Ring	Body Material	Max Restricted Pressure (psig/bar)	Max Unrestricted Pressure (psig/bar)
WP1-M58-0004	Neoprene	M5	M5	N/A	Stainless Steel	Steel	70 / 5	25 / 1.8
WP1-358-2000	Neoprene	10-32 UNF	10-32 UNF	N/A	Stainless Steel	Steel	70 / 5	25 / 1.8

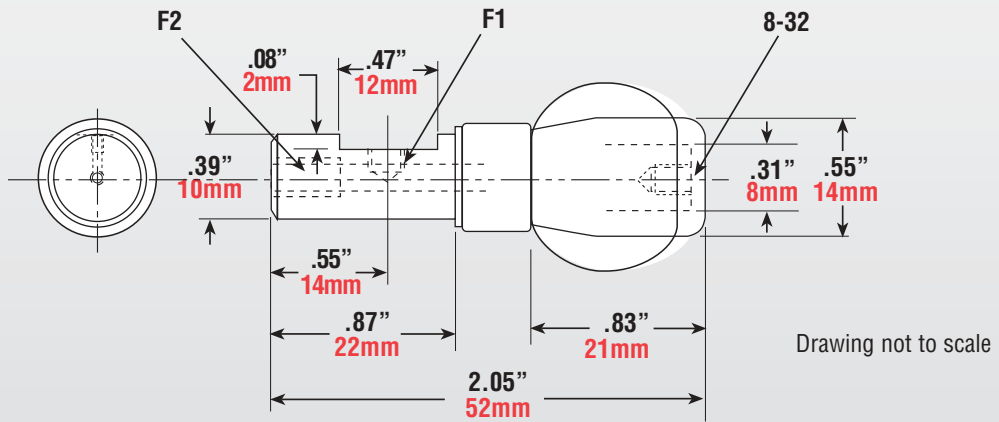

IMPERIAL

FORCE CURVES

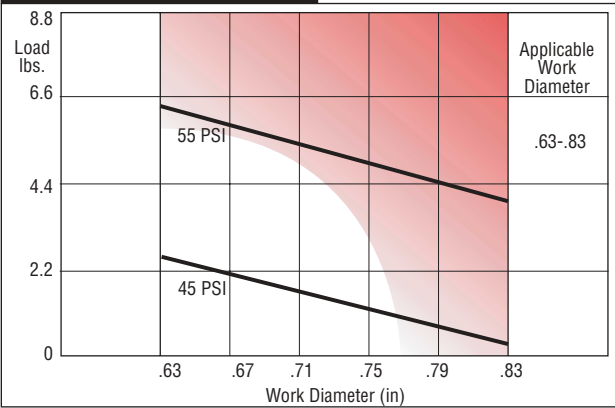

PRESSURE VS INFLATED DIAMETER

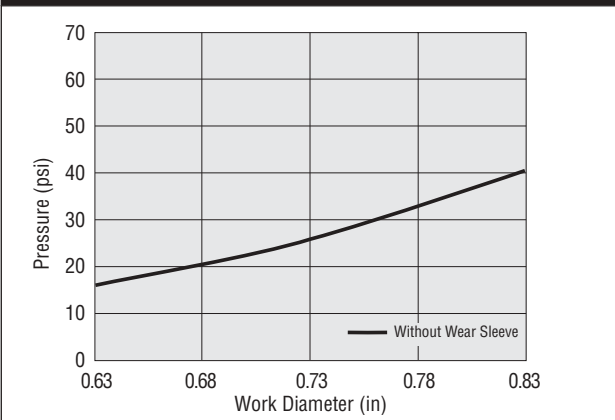

METRIC

FORCE CURVES

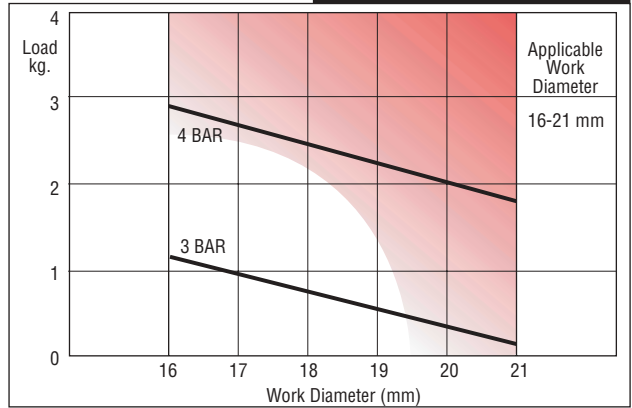

PRESSURE VS INFLATED DIAMETER

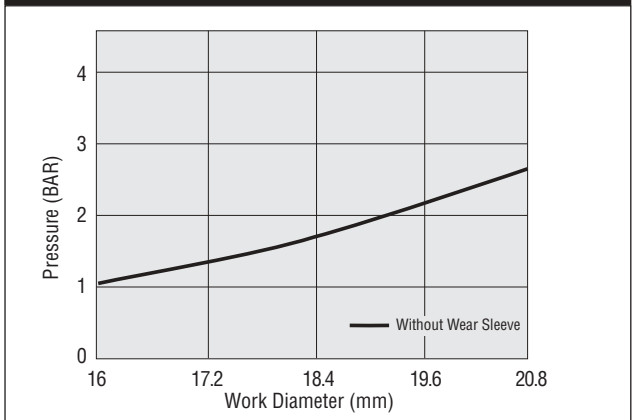

Assembly Order No.	Rubber Material	F1	F2	F3	Clamp Ring	Body Material	Max Restricted Pressure (psig/bar)	Max Unrestricted Pressure (psig/bar)
WP1-M58-0005	Neoprene	M5	M5	N/A	Stainless Steel	Steel	70 / 5	35 / 2.4
WP1-M58-0024	Silicone	M5	M5	N/A	Stainless Steel	Steel	25 / 1.8	15 / 1
WP1-358-2001	Neoprene	10-32 UNF	10-32 UNF	N/A	Stainless Steel	Steel	70 / 5	35 / 2.4
WP1-358-2009	Silicone	10-32 UNF	10-32 UNF	N/A	Stainless Steel	Steel	25 / 1.8	15 / 1

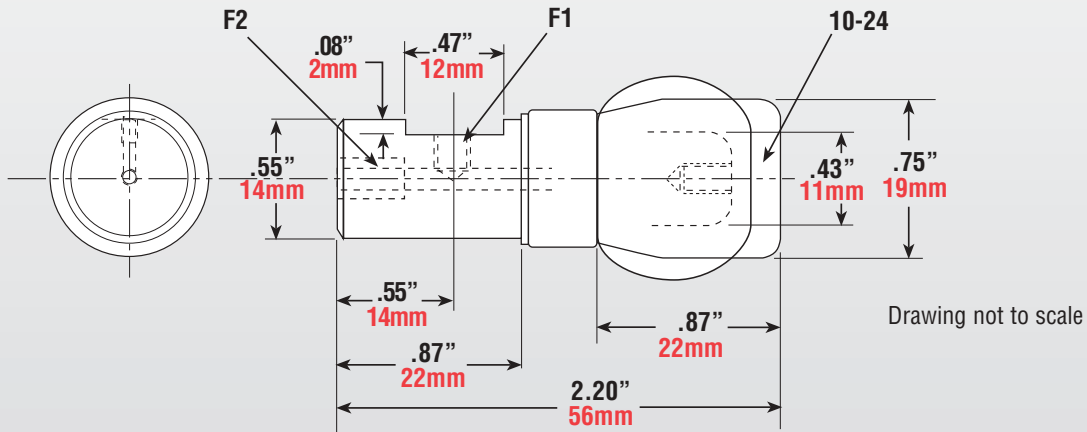

IMPERIAL

FORCE CURVES

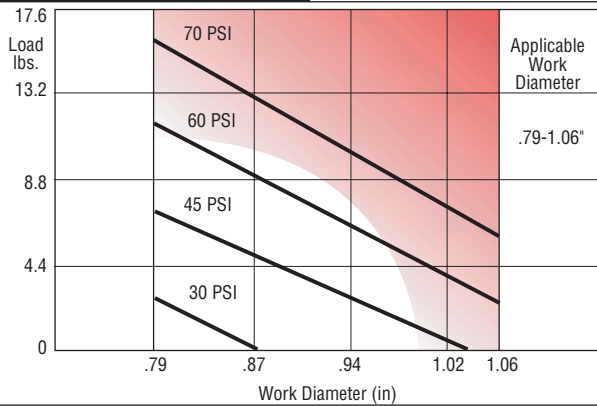

PRESSURE VS INFLATED DIAMETER

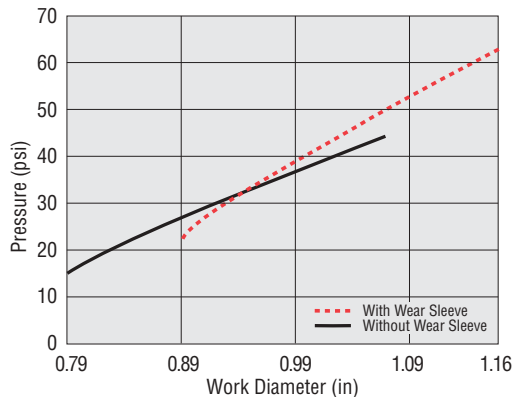

METRIC

FORCE CURVES

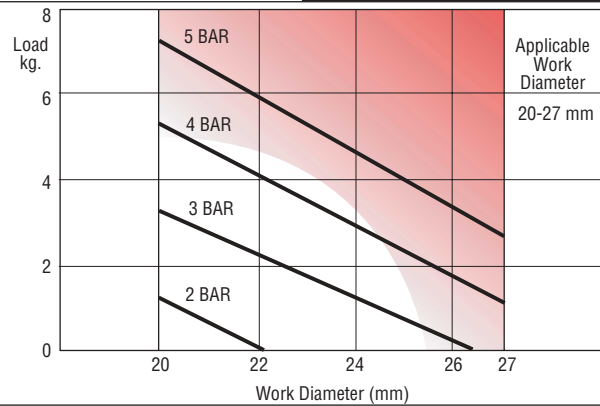

PRESSURE VS INFLATED DIAMETER

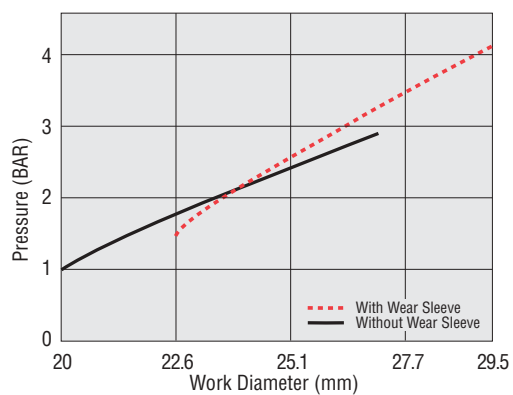

Assembly Order No.	Rubber Material	F1	F2	F3	Clamp Ring	Body Material	Max Restricted Pressure (psig/bar)	Max Unrestricted Pressure (psig/bar)
WP1-M58-0006	Neoprene	M5	M5	N/A	Stainless Steel	Steel	70 / 5	35 / 2.4
WP1-M58-0025	Silicone	M5	M5	N/A	Stainless Steel	Steel	25 / 1.8	15 / 1
WP1-358-2002	Neoprene	1/8-27 NPT	1/8-27 NPT	N/A	Stainless Steel	Steel	70 / 5	35 / 2.4
WP1-358-2010	Silicone	1/8-27 NPT	1/8-27 NPT	N/A	Stainless Steel	Steel	25 / 1.8	15 / 1

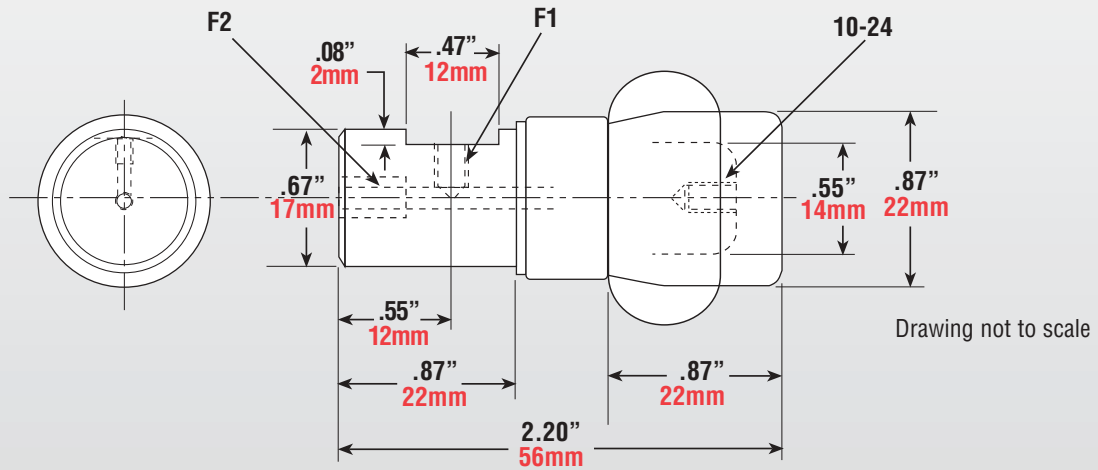

IMPERIAL

FORCE CURVES

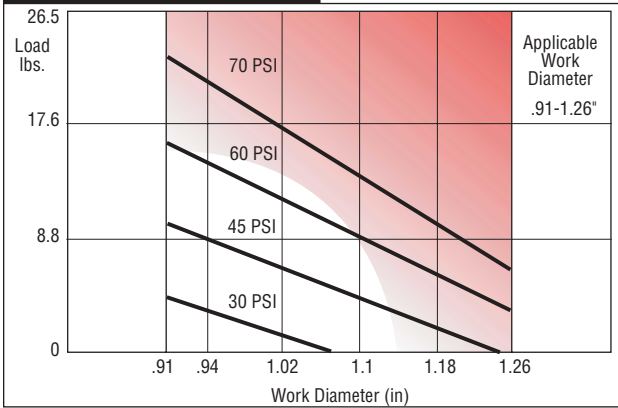

PRESSURE VS INFLATED DIAMETER

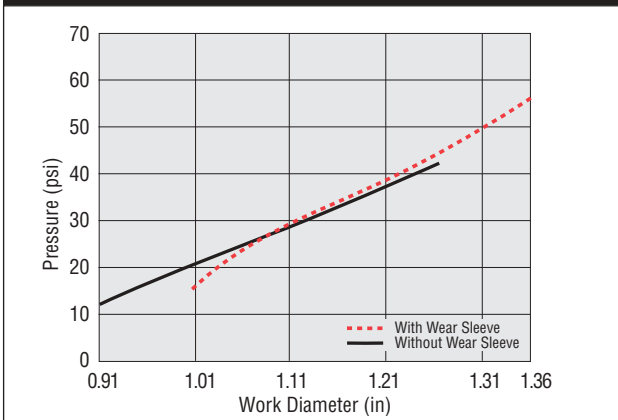

METRIC

FORCE CURVES

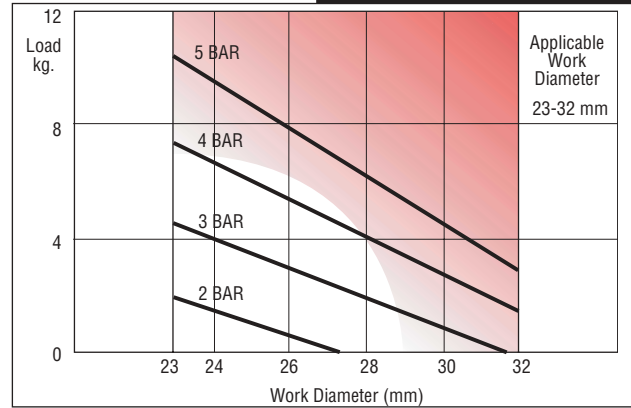

PRESSURE VS INFLATED DIAMETER

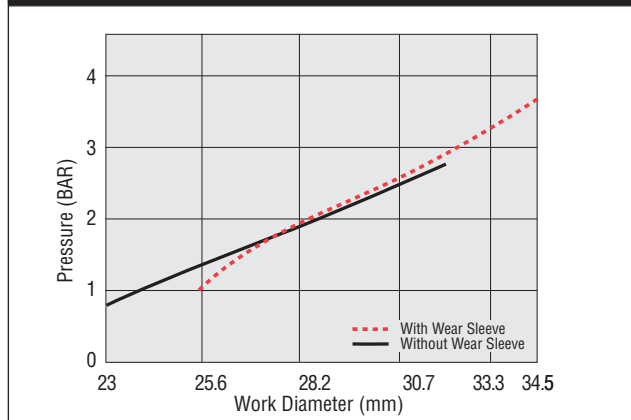

Assembly Order No.	Rubber Material	F1	F2	F3	Clamp Ring	Body Material	Max Restricted Pressure (psig/bar)	Max Unrestricted Pressure (psig/bar)
WP1-M58-0007	Neoprene	M5	M5	N/A	Stainless Steel	Steel	70 / 5	35 / 2.4
WP1-M58-0018	Silicone	M5	M5	N/A	Stainless Steel	Steel	25 / 1.8	15 / 1
WP1-358-2003	Neoprene	1/8-27 NPT	1/8-27 NPT	N/A	Stainless Steel	Steel	70 / 5	35 / 2.4
WP1-358-2011	Silicone	1/8-27 NPT	1/8-27 NPT	N/A	Stainless Steel	Steel	25 / 1.8	15 / 1

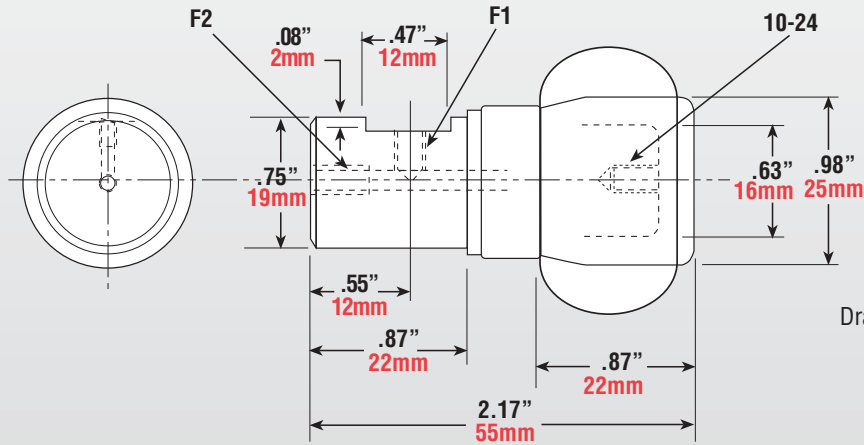

Drawing not to scale

IMPERIAL

METRIC

FORCE CURVES

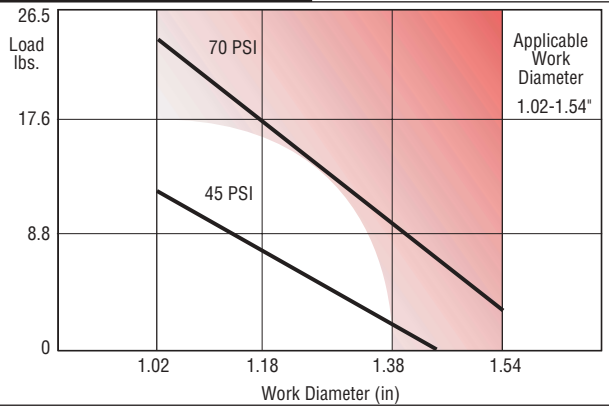

FORCE CURVES

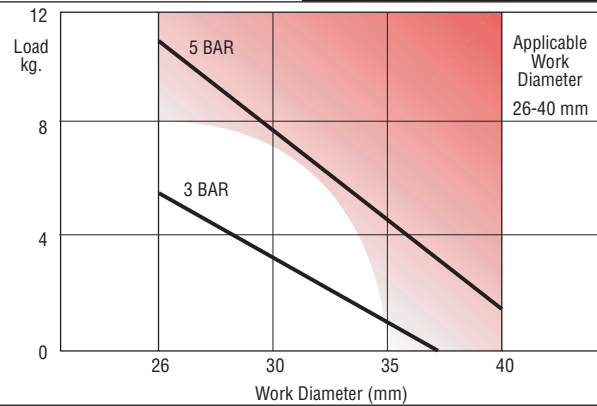

PRESSURE VS INFLATED DIAMETER

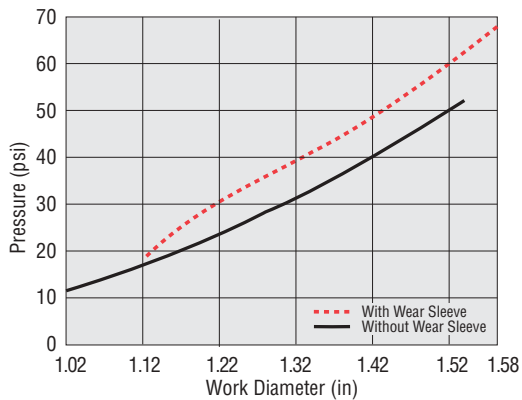

PRESSURE VS INFLATED DIAMETER

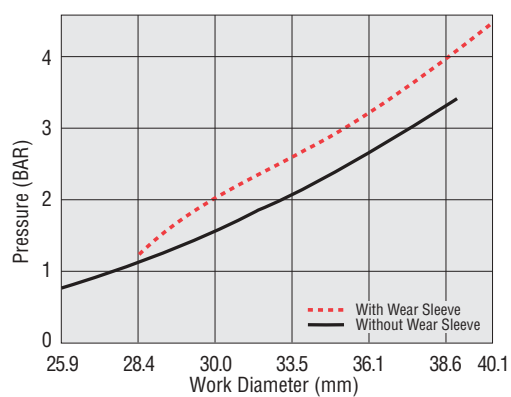

Assembly Order No.	Rubber Material	F1	F2	F3	Clamp Ring	Body Material	Max Restricted Pressure (psig/bar)	Max Unrestricted Pressure (psig/bar)
WP1-M58-0008	Neoprene	M5	M5	N/A	Stainless Steel	Steel	70 / 5	35 / 2.4
WP1-M58-0026	Silicone	M5	M5	N/A	Stainless Steel	Steel	25 / 1.8	15 / 1
WP1-358-2004	Neoprene	1/8-27 NPT	1/8-27 NPT	N/A	Stainless Steel	Steel	70 / 5	35 / 2.4
WP1-358-2012	Silicone	1/8-27 NPT	1/8-27 NPT	N/A	Stainless Steel	Steel	25 / 1.8	15 / 1

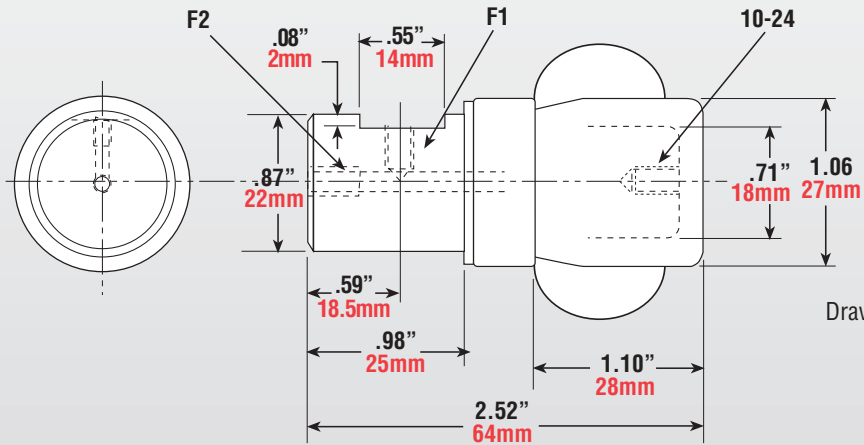

IMPERIAL

FORCE CURVES

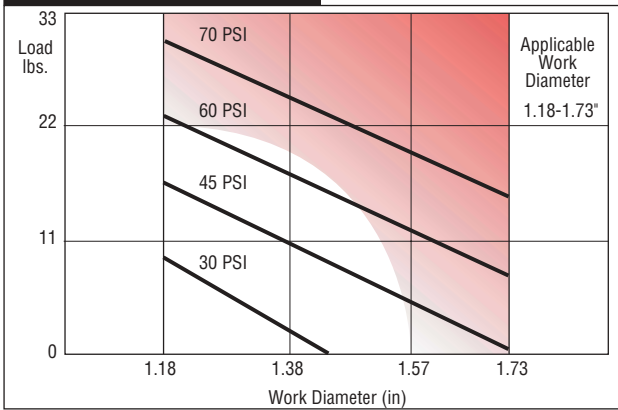

PRESSURE VS INFLATED DIAMETER

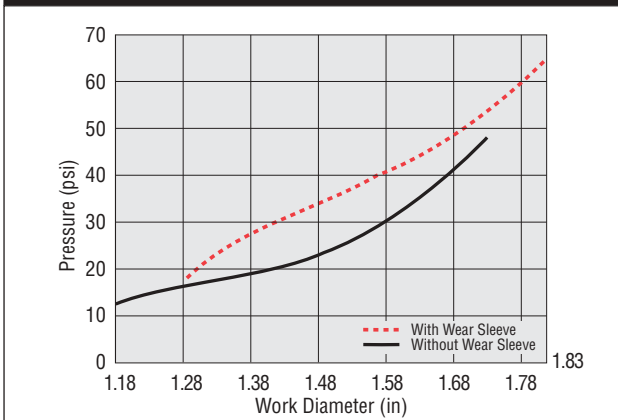

METRIC

FORCE CURVES

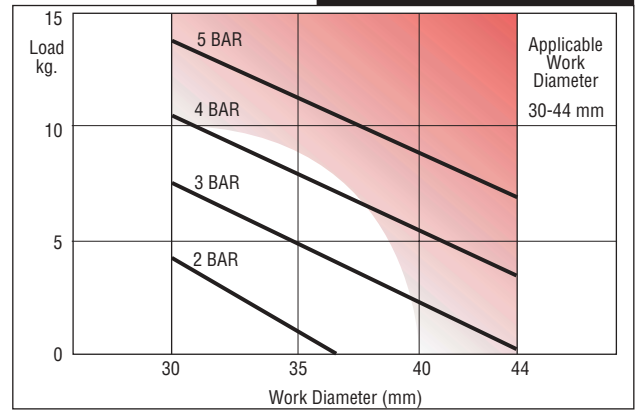

PRESSURE VS INFLATED DIAMETER

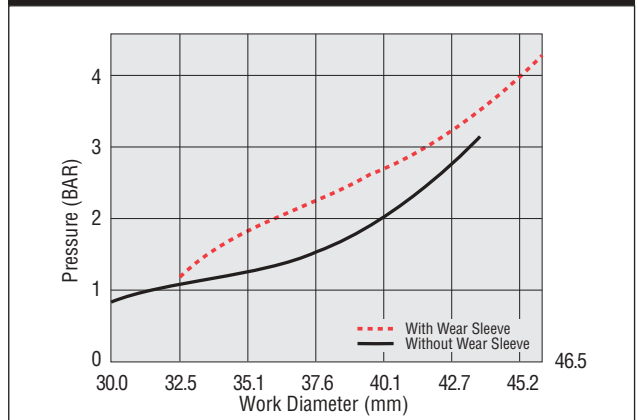

Assembly Order No.	Rubber Material	F1	F2	F3	Clamp Ring	Body Material	Max Restricted Pressure (psig/bar)	Max Unrestricted Pressure (psig/bar)
WP1-M58-0009	Neoprene	M5	M5	N/A	Stainless Steel	Steel	70 / 5	35 / 2.4
WP1-M58-0019	Silicone	M5	M5	N/A	Stainless Steel	Steel	25 / 1.8	15 / 1
WP1-358-2005	Neoprene	1/8-27 NPT	1/8-27 NPT	N/A	Stainless Steel	Steel	70 / 5	35 / 2.4
WP1-358-2013	Silicone	1/8-27 NPT	1/8-27 NPT	N/A	Stainless Steel	Steel	25 / 1.8	12 / 0.8

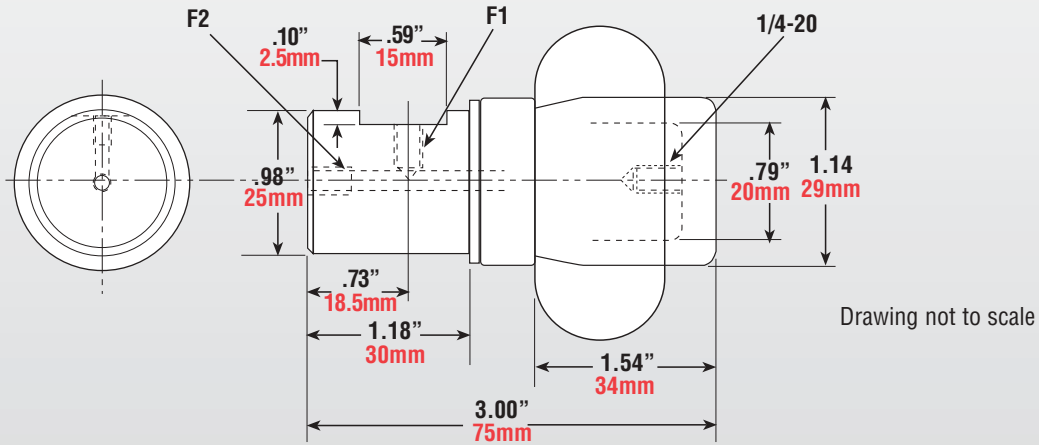

IMPERIAL

METRIC

FORCE CURVES

FORCE CURVES

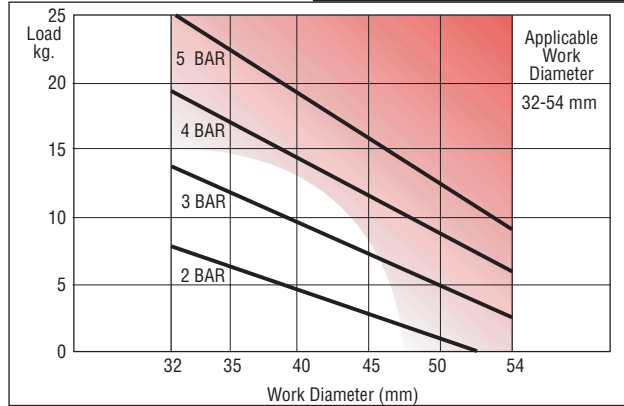
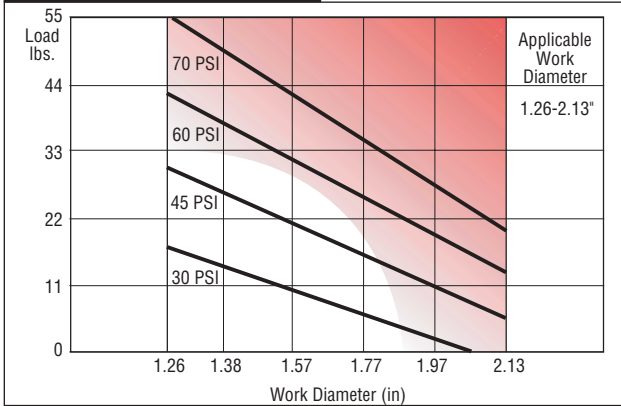

PRESSURE VS INFLATED DIAMETER

PRESSURE VS INFLATED DIAMETER

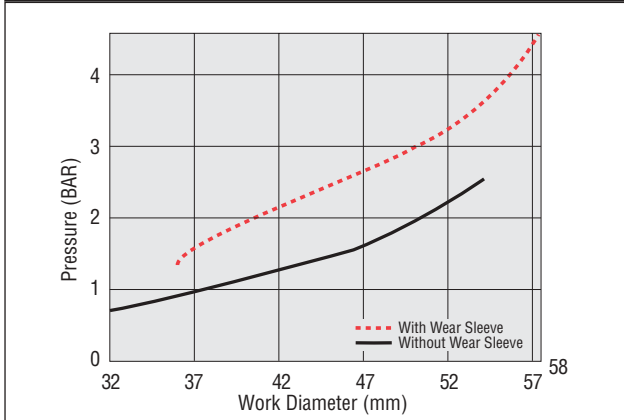
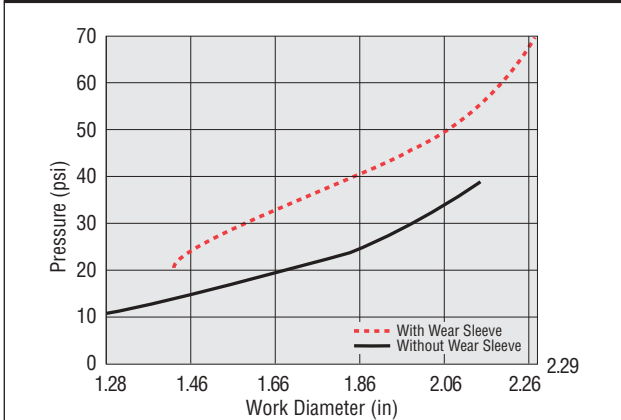

Assembly Order No.	Rubber Material	F1	F2	F3	Clamp Ring	Body Material	Max Restricted Pressure (psig/bar)	Max Unrestricted Pressure (psig/bar)
WP1-M58-0011	Neoprene	PT 1/8	M6	N/A	Stainless Steel	Aluminum	70 / 5	35 / 2.4
WP1-M58-0028	Silicone	PT 1/8	M6	N/A	Stainless Steel	Aluminum	25 / 1.8	12 / 0.8
WP1-358-2006	Neoprene	1/8-27 NPT	1/8-27 NPT	N/A	Stainless Steel	Aluminum	70 / 5	35 / 2.4
WP1-358-2014	Silicone	1/8-27 NPT	1/8-27 NPT	N/A	Stainless Steel	Aluminum	25 / 1.8	12 / 0.8

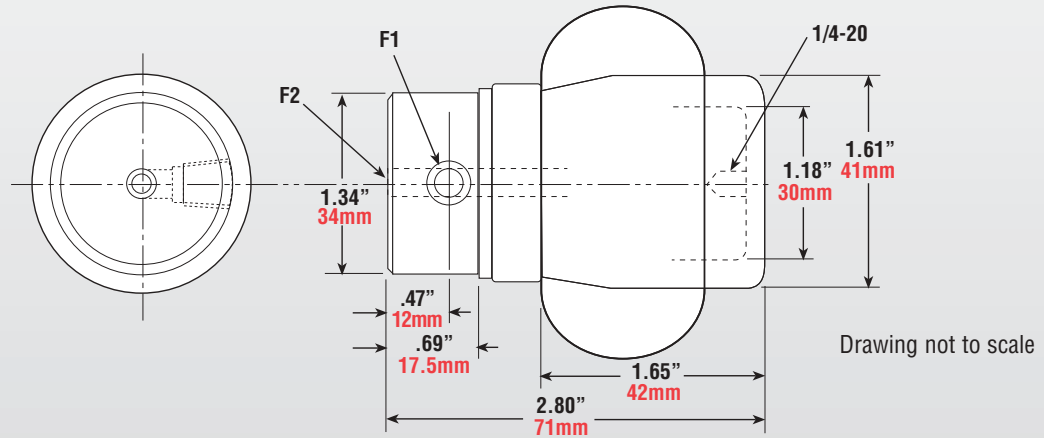

IMPERIAL

FORCE CURVES

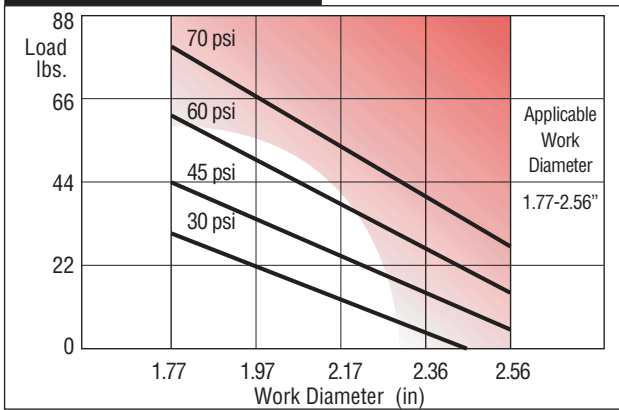

PRESSURE VS INFLATED DIAMETER

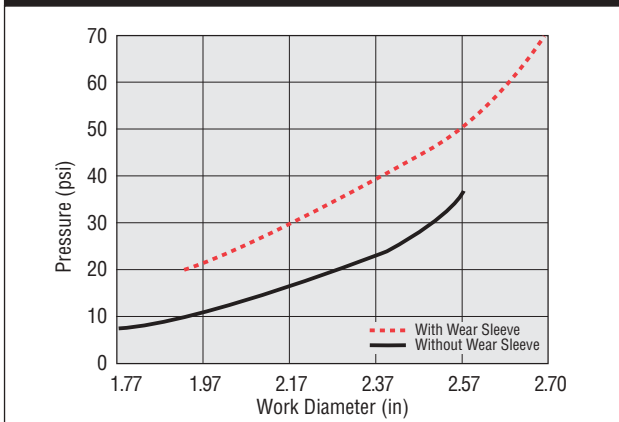

METRIC

FORCE CURVES

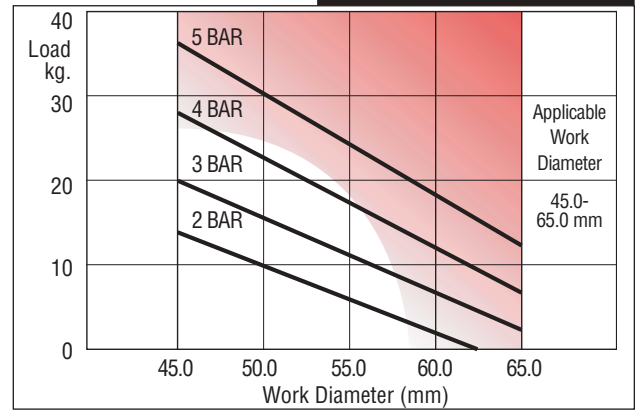

PRESSURE VS INFLATED DIAMETER

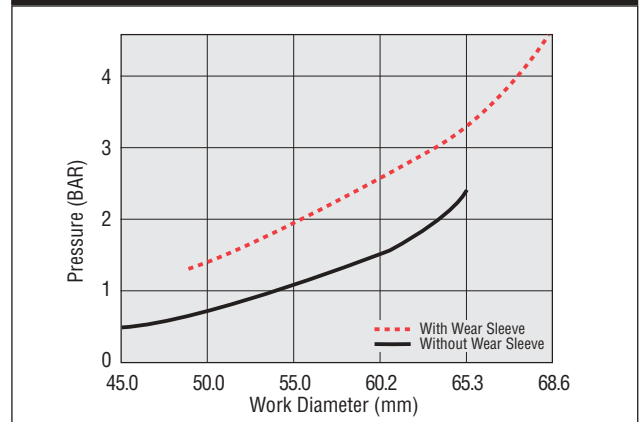

Assembly Order No.	Rubber Material	F1	F2	F3	Clamp Ring	Body Material	Max Restricted Pressure (psig/bar)	Max Unrestricted Pressure (psig/bar)
WP1-M58-0012	Neoprene	M6	M6	M6	Stainless Steel	Aluminum	70 / 5	35 / 2.4
WP1-358-2007	Neoprene	1/8-27 NPT	1/8-27 NPT	10-24 UNC	Stainless Steel	Aluminum	70 / 5	35 / 2.4

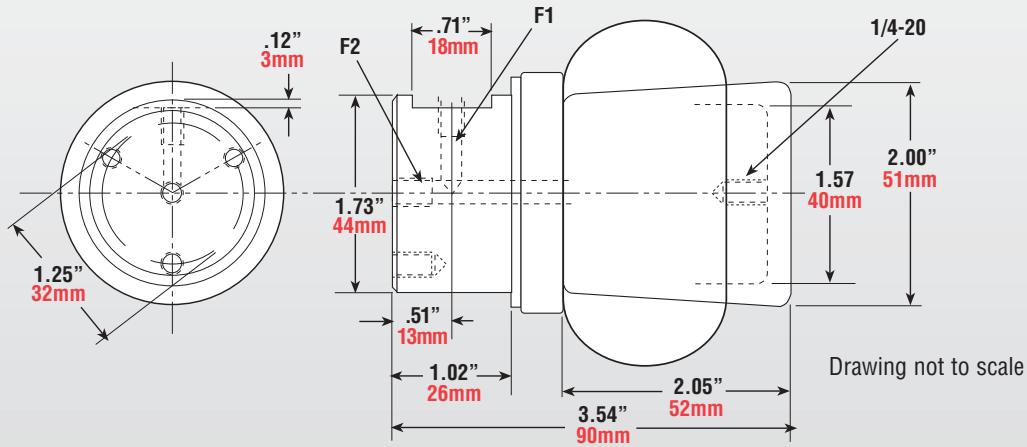

IMPERIAL

METRIC

FORCE CURVES

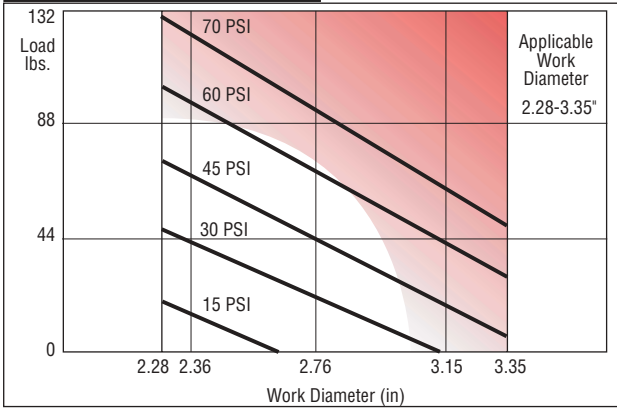

FORCE CURVES

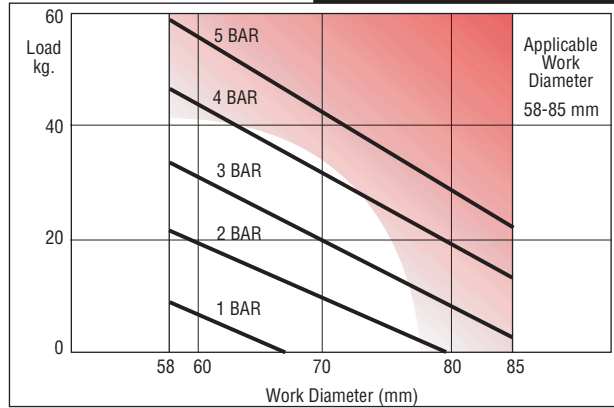

PRESSURE VS INFLATED DIAMETER

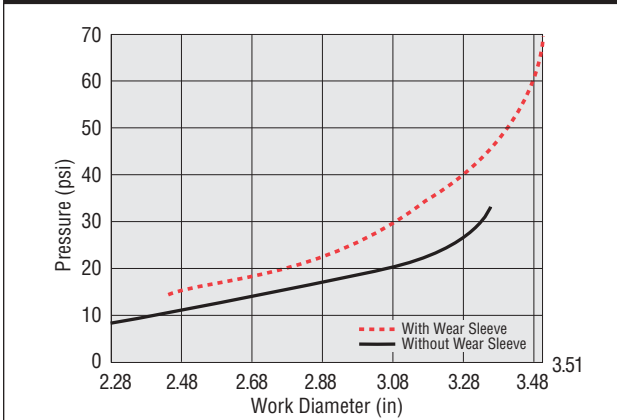

PRESSURE VS INFLATED DIAMETER

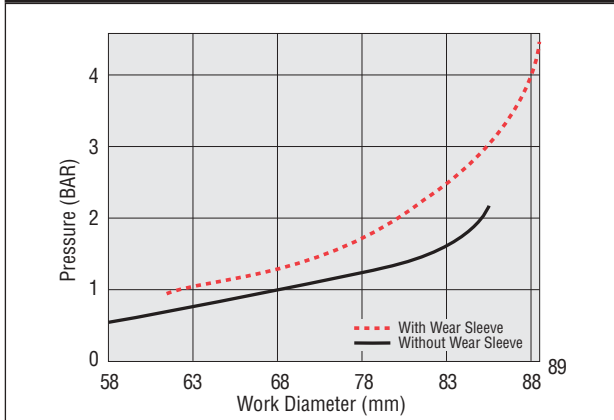

Assembly Order No.	Rubber Material	F1	F2	F3	Clamp Ring	Body Material	Max Restricted Pressure (psig/bar)	Max Unrestricted Pressure (psig/bar)
WP1-M58-0013	Neoprene	M6	M6	M6	Stainless Steel	Aluminum	70 / 5	35 / 2.4
WP1-358-2008	Neoprene	1/8-27 NPT	1/8-27 NPT	10-24 UNC	Stainless Steel	Aluminum	70 / 5	35 / 2.4

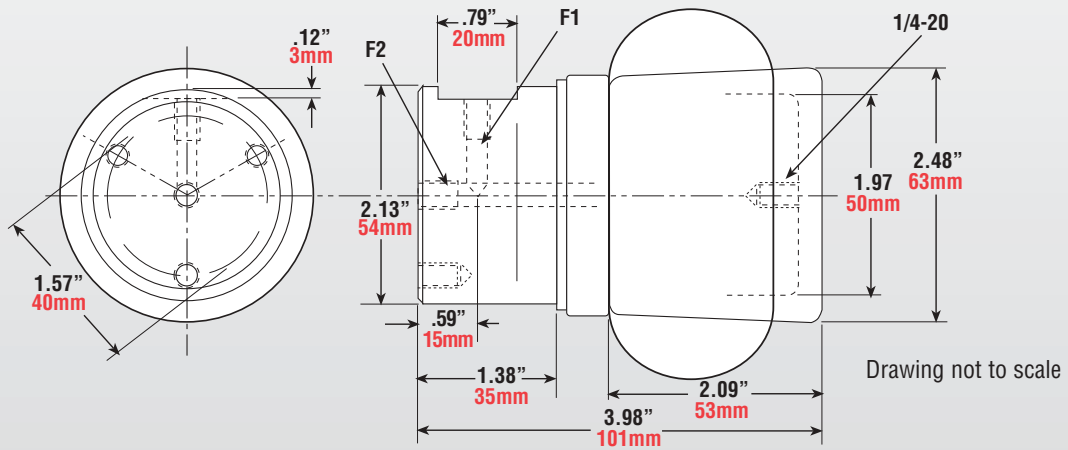

IMPERIAL

FORCE CURVES

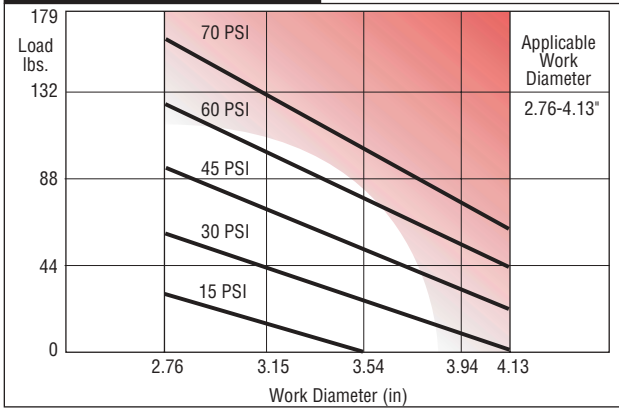

PRESSURE VS INFLATED DIAMETER

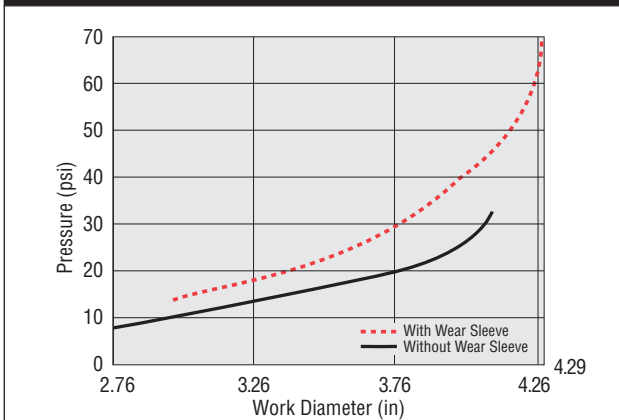

METRIC

FORCE CURVES

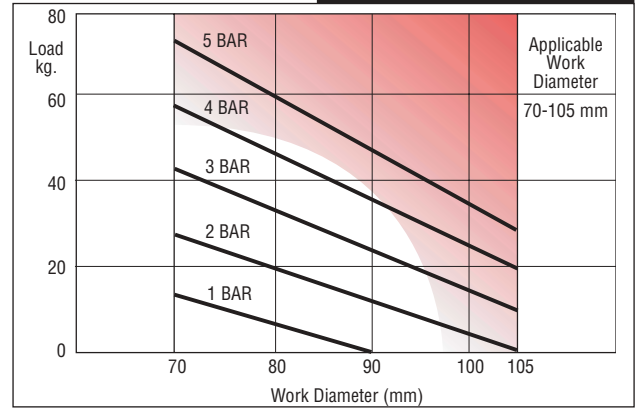

PRESSURE VS INFLATED DIAMETER

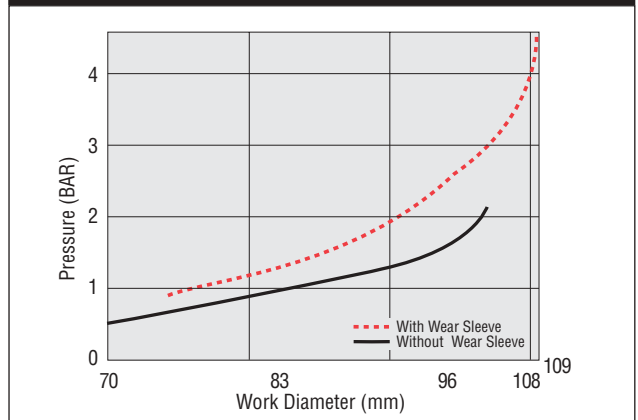

Assembly Order No.	Rubber Material	F1	F2	Clamp Ring	Body Material	Max Restricted Pressure (psig/bar)	Max Unrestricted Pressure (psig/bar)
WP1-358-7000	Neoprene	10-24 UNC	10-32 UNF	Stainless Steel	Aluminum	20 / 1.5	10 / 0.75
WP1-358-7004	Silicone	10-24 UNC	10-32 UNF	Stainless Steel	Aluminum	15 / 1	7.5 / 0.5
WP1-M58-5001	Neoprene	M5	M5	Stainless Steel	Aluminum	20 / 1.5	10 / 0.75
WP1-M58-5005	Silicone	M5	M5	Stainless Steel	Aluminum	15 / 1	7.5 / 0.5

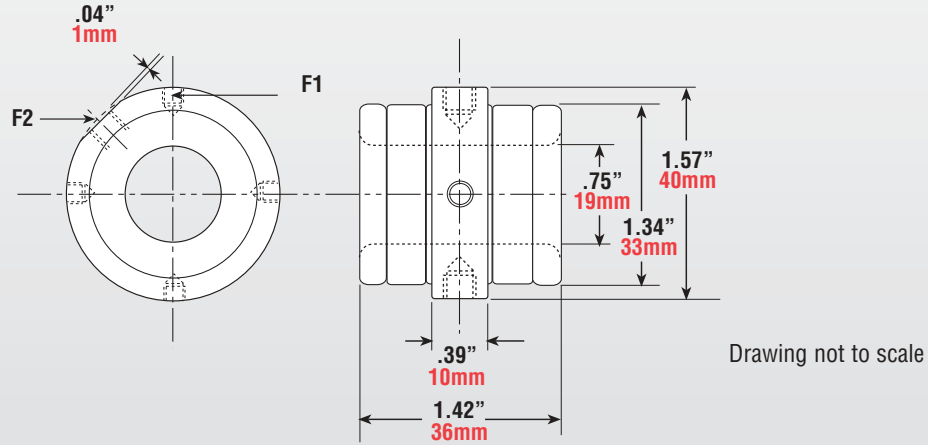

IMPERIAL

METRIC

FORCE CURVES

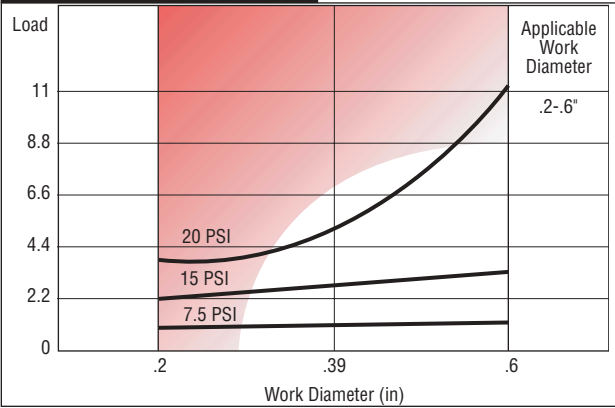

FORCE CURVES

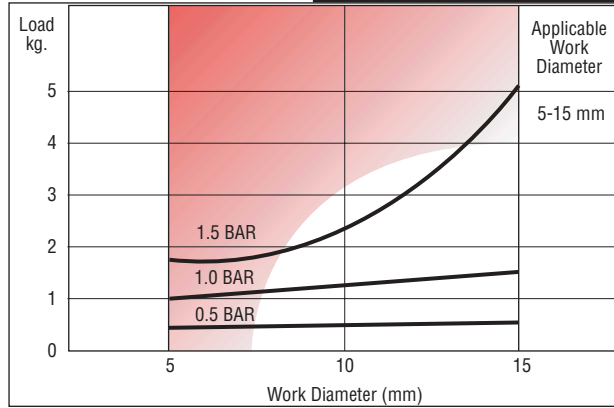

PRESSURE VS INFLATED DIAMETER

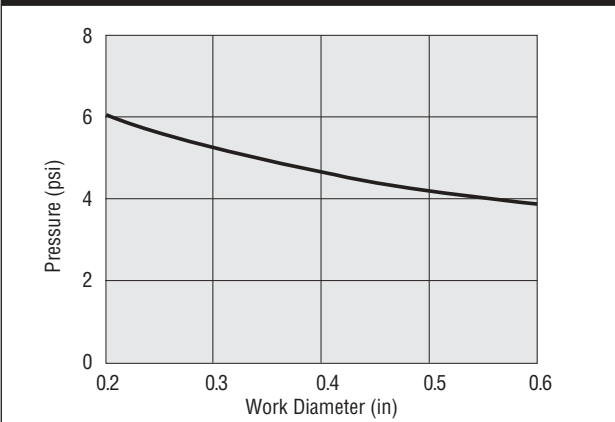

PRESSURE VS INFLATED DIAMETER

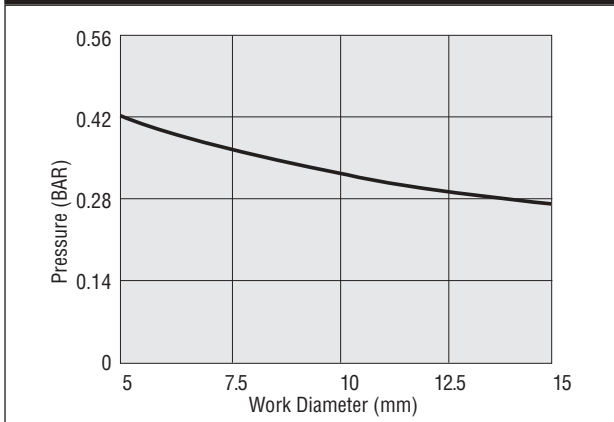

Assembly Order No.	Rubber Material	F1	F2	Clamp Ring	Body Material	Max Restricted Pressure (psig/bar)	Max Unrestricted Pressure (psig/bar)
WP1-358-7001	Neoprene	10-24 UNC	10-32 UNF	Stainless Steel	Aluminum	20 / 1.5	10 / 0.75
WP1-358-7005	Silicone	10-24 UNC	10-32 UNF	Stainless Steel	Aluminum	15 / 1	7.5 / 0.5
WP1-M58-5002	Neoprene	M6	M6	Stainless Steel	Aluminum	20 / 1.5	10 / 0.75
WP1-M58-5006	Silicone	M6	M6	Stainless Steel	Aluminum	15 / 1	7.5 / 0.5

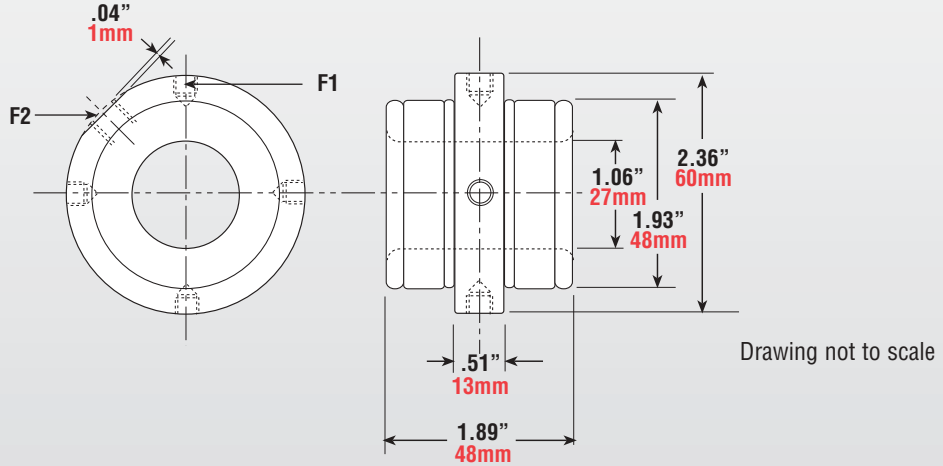

IMPERIAL

FORCE CURVES

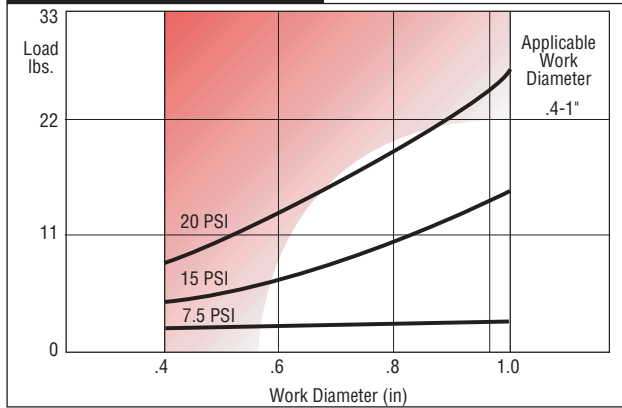

PRESSURE VS INFLATED DIAMETER

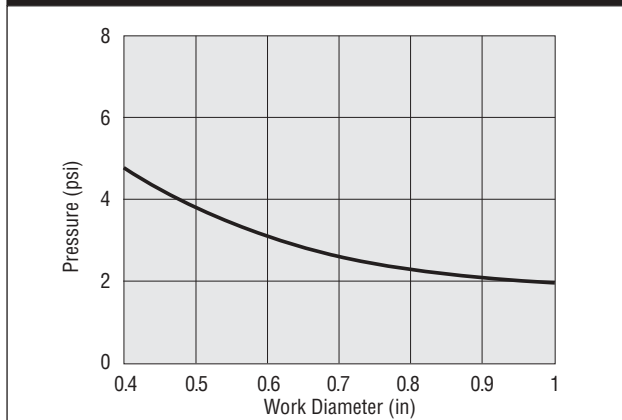

METRIC

FORCE CURVES

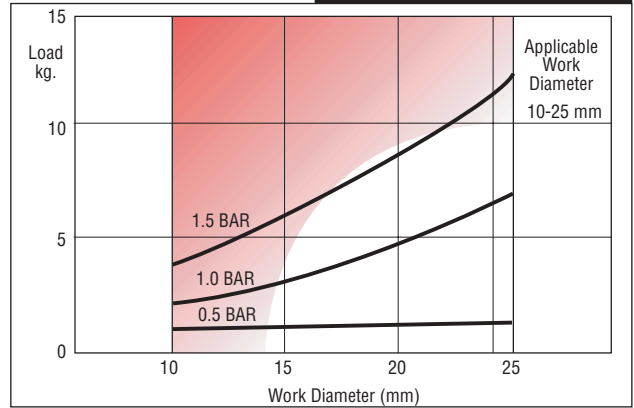

PRESSURE VS INFLATED DIAMETER

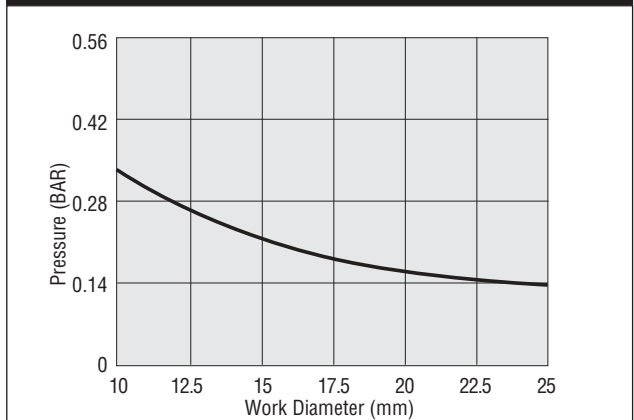

Assembly Order No.	Rubber Material	F1	F2	Clamp Ring	Body Material	Max Restricted Pressure (psig/bar)	Max Unrestricted Pressure (psig/bar)
WP1-358-7002	Neoprene	10-24 UNC	1/8 - 27 NPT	Stainless Steel	Aluminum	20 / 1.5	10 / 0.75
WP1-358-7006	Silicone	10-24 UNC	1/8 - 27 NPT	Stainless Steel	Aluminum	15 / 1	7.5 / 0.5
WP1-M58-5003	Neoprene	M5	M6	Stainless Steel	Aluminum	20 / 1.5	10 / 0.75
WP1-M58-5007	Silicone	M5	M6	Stainless Steel	Aluminum	15 / 1	7.5 / 0.5

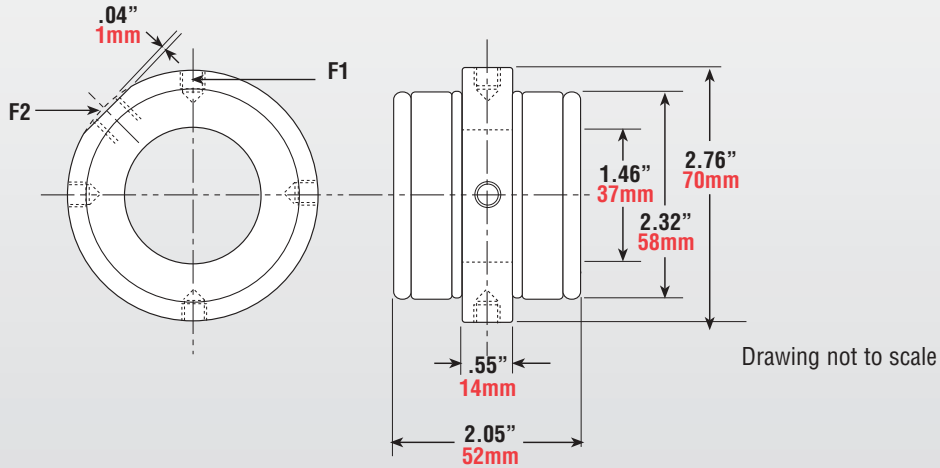

IMPERIAL

METRIC

FORCE CURVES

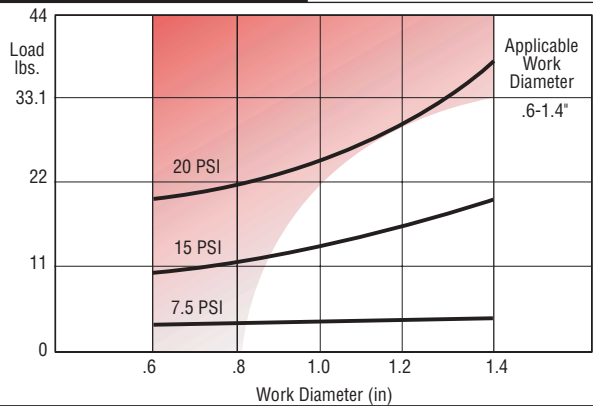

FORCE CURVES

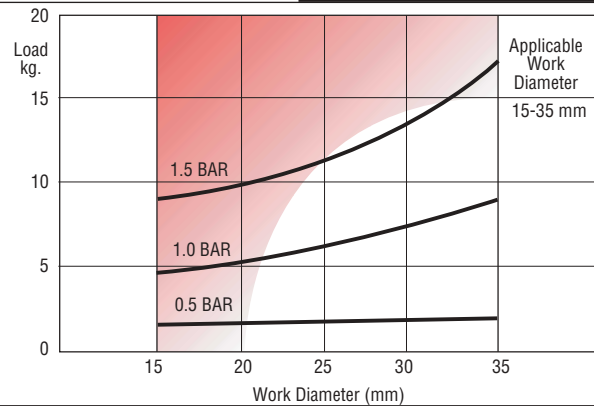

PRESSURE VS INFLATED DIAMETER

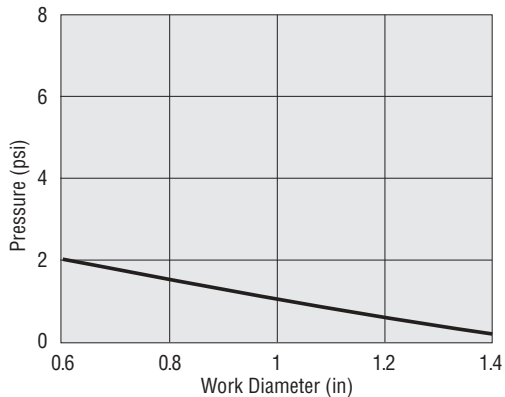

PRESSURE VS INFLATED DIAMETER

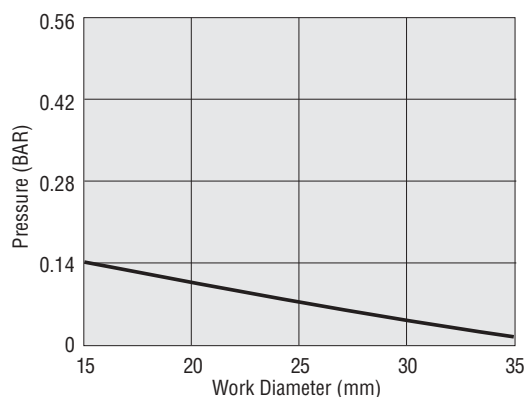

Assembly Order No.	Rubber Material	F1	F2	Clamp Ring	Body Material	Max Restricted Pressure (psig/bar)	Max Unrestricted Pressure (psig/bar)
WP1-358-7003	Neoprene	10-24 UNC	1/8 - 27 NPT	Stainless Steel	Aluminum	20 / 1.5	10 / 0.75
WP1-358-7007	Silicone	10-24 UNC	1/8 - 27 NPT	Stainless Steel	Aluminum	15 / 1	7.5 / 0.5
WP1-M58-5004	Neoprene	M8	PT 1/8	Stainless Steel	Aluminum	20 / 1.5	10 / 0.75
WP1-M58-5008	Silicone	M8	PT 1/8	Stainless Steel	Aluminum	15 / 1	7.5 / 0.5

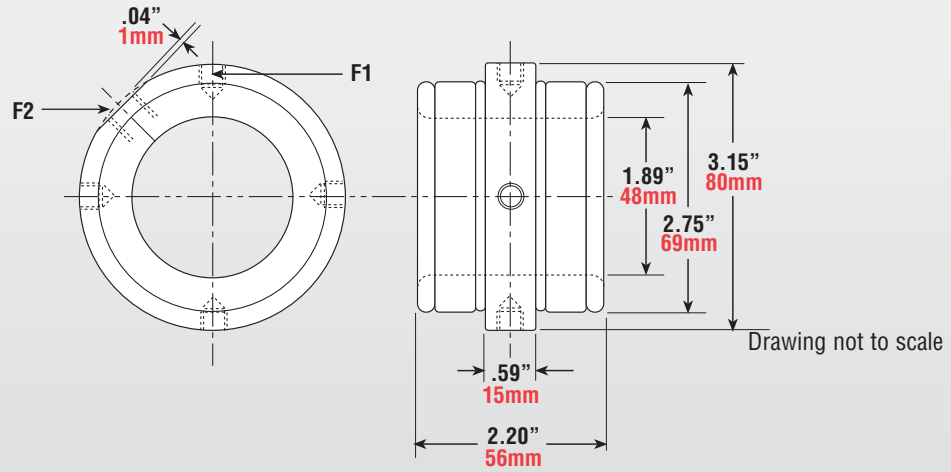

IMPERIAL

FORCE CURVES

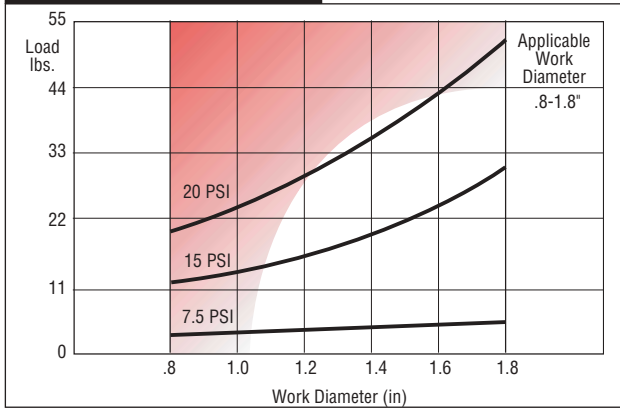

PRESSURE VS INFLATED DIAMETER

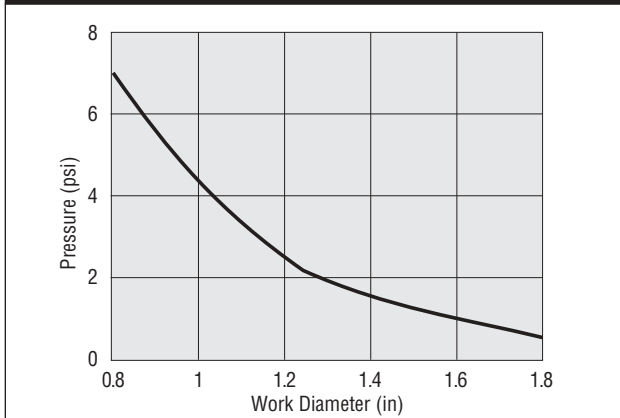

METRIC

FORCE CURVES

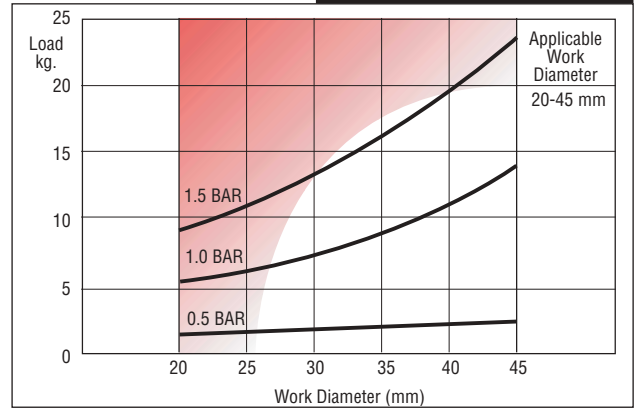

PRESSURE VS INFLATED DIAMETER

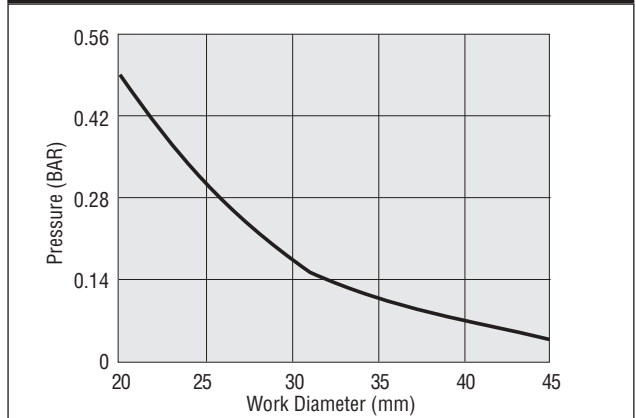

DESIGN PARAMETER SHEET

Picking Inside an Object

Total Load Required: _____ (lbs./kg)

Available Air Pressure: _____ (psig/bar)

Dimensions of contact surface (Please sketch below):

Width of Contact Surface: _____ (in/mm)

Depth of Contact Surface: _____ (in/mm)

Object Material: _____

- Dry
- Wet
- Smooth
- Abrasive

Environmental Conditions:

Cycle Rate: _____ (CPM/Hz)

Response Time Required: _____ (seconds)

Special Requirements:

Remarks:

Name _____

Company _____

Address _____

City/Country/Code _____

Telephone _____

Date ____ / ____ / ____

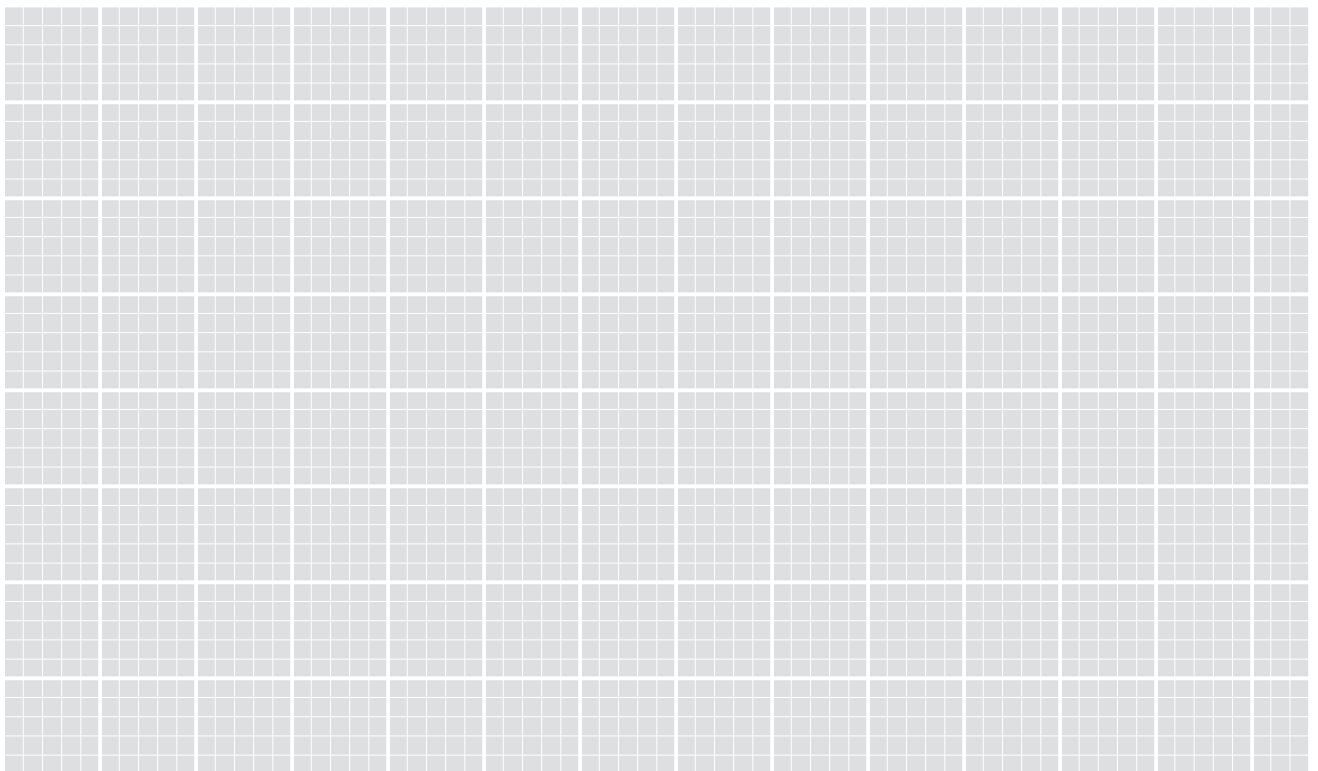

DESIGN PARAMETER SHEET

Picking Outside an Object

Total Load Required: _____ (lbs./kg)

Available Air Pressure: _____ (psig/bar)

Dimensions of contact surface (Please sketch below):

Width of Contact Surface: _____ (in/mm)

Depth of Contact Surface: _____ (in/mm)

Object Material: _____

- Dry
- Wet
- Smooth
- Abrasive

Environmental Conditions:

Cycle Rate: _____ (CPM/Hz)

Response Time Required: _____ (seconds)

Special Requirements:

Remarks:

Name _____

Company _____

Address _____

City/Country/Code _____

Telephone _____

Date ____ / ____ / ____

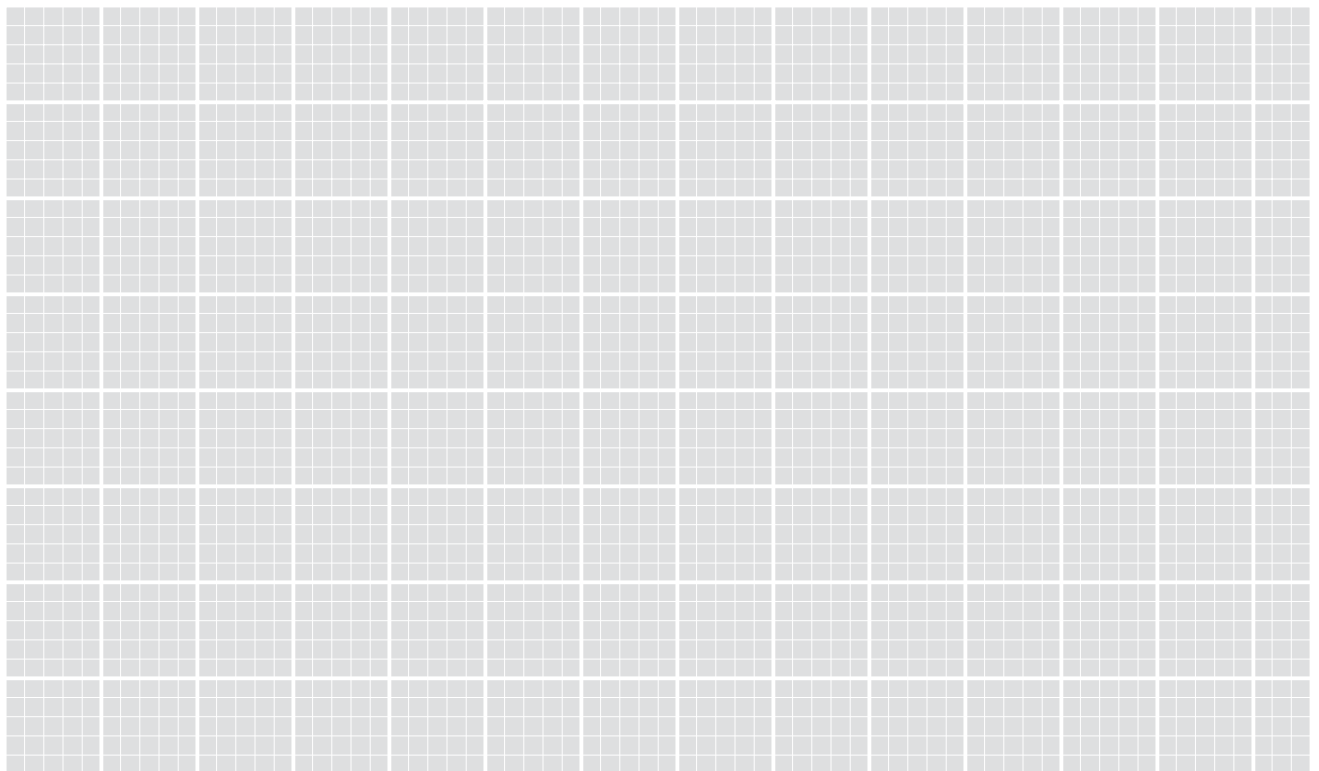

AIRPICKER[®] AIRGRIPPER[™]

END-EFFECTORS



ENGINEERING MANUAL & DESIGN GUIDE

Stocked and Distributed by



Firestone

World's Number 1
Air Spring.



FIRESTONE INDUSTRIAL PRODUCTS COMPANY

12650 Hamilton Crossing Blvd., Carmel, Indiana 46032, 1-800-888-0650

www.firestoneindustrial.com/Industrial